

Stile, Rail and Reinforcement Block Sizes and Locations .....	3.3
90 Minute Positive Pressure Steel Fire Door Reinforcement Sizes & Locations .....	3.5
Door Slab Trimming .....	3.6
Door Slab Resizing.....	3.7
90 Minute Fire Door Slab Resizing.....	3.11
Slab Repair.....	3.12
Hinge Preparation (Except 90 Minute Steel Fire Door) .....	3.15
Lock Preparation (Except 90 Minute Steel Fire Door).....	3.20
Lock Preparation 90 Minute Steel Fire Door .....	3.22
Multipoint Lock Preparation (Except Fire & Steel Doors).....	3.24
Classic-Craft Panel Installation.....	3.34
Doorlite and Panel Preparation.....	3.36
Doorlite & Designline Panel Installation.....	3.38
Impact Doorlite Installation .....	3.43
Hinge Installation.....	3.44
Astragal Installation .....	3.47
Door Bottom Selection & Installation .....	3.50
Grille Installation .....	3.53
Lite Divider Installation (Classic-Craft) .....	3.56
SDL Bar Installation Instructions (Smooth Star / Fiber Classic).....	3.58
Dentil Shelf Attachment (Classic-Craft).....	3.68
Dentil Shelf Attachment (Smooth Star / Fiber Classic).....	3.70
Rain Deflector Installation .....	3.71
Decorative Strap Hinge & Clavos Application .....	3.72
Special Shop Painting.....	3.75
Special Shop Machining .....	3.76

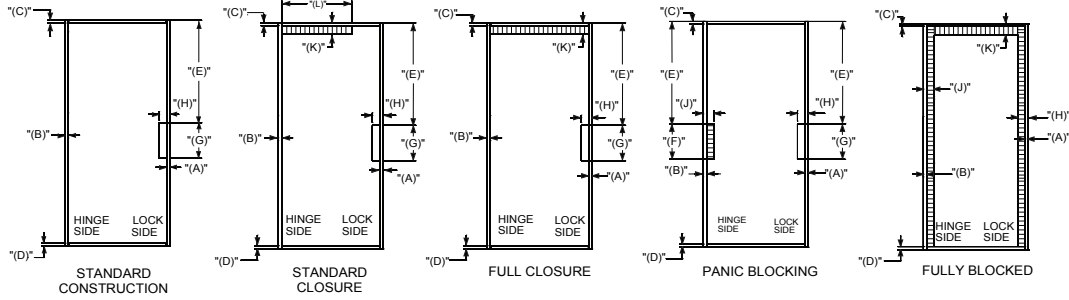

## 6/8 AND 7/0 SMOOTH STAR AND FIBER CLASSIC BLOCKING OPTIONS

NOTE: FULLY BLOCKED NOT AVAILABLE IN FLUSH GLAZED.



**Note:**  
Shaded blocks are extra-cost options.

## 8/0 SMOOTH STAR AND FIBER CLASSIC BLOCKING OPTIONS

NOTE: FULLY BLOCKED NOT AVAILABLE IN FLUSH GLAZED.

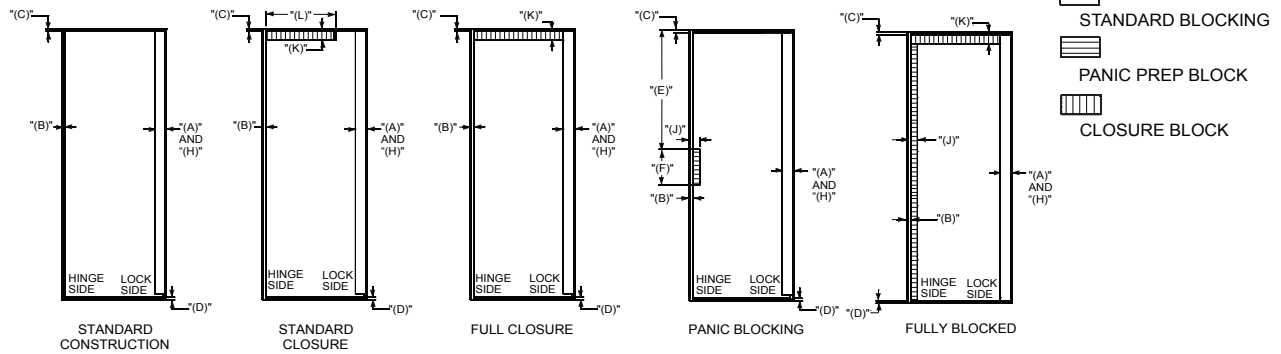

## STEEL BLOCKING OPTIONS

NOTE: ONLY ONE STILE CAN BE FULLY BLOCKED, EITHER LOCK OR HINGE ON STEEL PRODUCT.

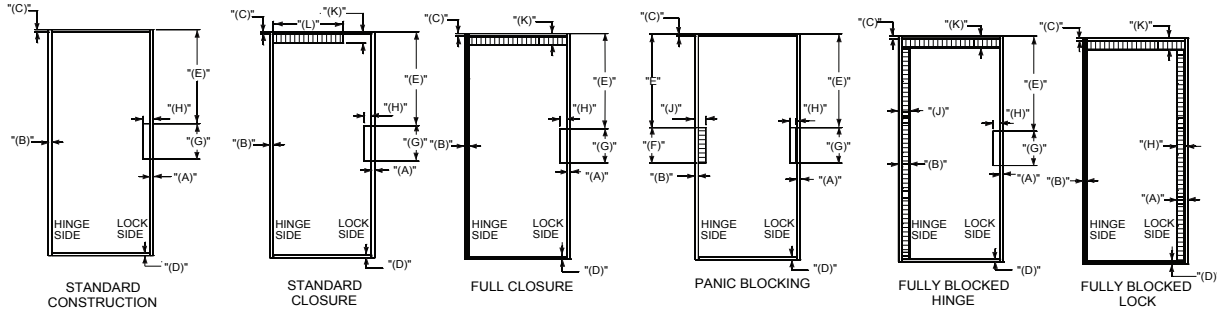

## CLASSIC CRAFT BLOCKING OPTIONS

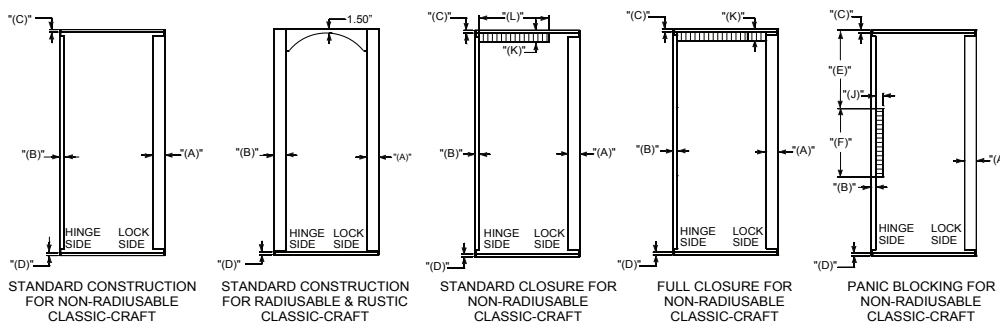

**Note:**  
See Chart for Dimensions on Next Page

# Stile, Rail, and Reinforcement Block Sizes and Locations

Door Preparation

	A Lock Stile Width (Inches)	B Hinge Stile Width (Inches)	C Top Rail Height (Inches)	D Bottom Rail Height (Inches)	E Lock & Panic Block Location (Inches)	F Panic Block Length (Inches)	G Lock Block Length (Inches)	H Lock Block Width = Lock Stile Width + Lock Block Width (Inches)	J Panic Block Width = Hinge Stile + Panic Block Width (Inches)	K Closure Block Height = Top Rail Height + Closure Height (Inches)	L Closure Block Size Width (Inches)
<b>Classic Craft</b>											
6/8 U4 Doors					27 5/8	24	Not Required Wide Lock Stile See Column "A"	3 7/8	4 1/8	24	
6/8 U4 Rustic & Canvas Non-Radius	1 1/4	1 15/16	1 15/16	43 5/8							
8/0 U4 Doors				Not Available							
8/0 U4 Rustic Non-Radius											
6/8 and 8/0 U4 Flush Glazed and Molded Open Doors	3 3/32	3 7/8	1 1/2	1 15/16			Not Required Wide Stiles See Columns "A & B"	Not Available	Not Available Use Non-Radiusable Door		
6/8 U4 Arched & Radius Rustic & Canvas Doors	1 1/4	1 1/2	1 15/16								
8/0 U4 Fire Doors	1 1/4	1 1/4	1 15/16								
8/0 U4 Fire Doors							Not Available HPC Filled				
<b>Fiber Classic</b>											
6/8 U4 Doors					36	12 1/2	22 1/2	3 15/32	3 15/32	4 1/32	28 5/8
6/8 U4 Flush Glazed and Molded Open Doors	1 3/32	1 3/32	15/16	36	Not Available						
7/0 U4 Doors				40							
8/0 U4 Doors	3 15/16	1 3/32	15/16	42	12 1/2		Not Required Wide Lock Stile See Column "A"	3 4/8	4 1/32	28 5/8	
8/0 U4 Flush Glazed and Molded Open Doors					Not Available						
<b>Smooth Star</b>											
6/8 U4 Doors					36	12 1/2	12 1/2	3 15/32	3 15/32	4 1/32	28 5/8
6/8 U4 Flush Glazed and Molded Open Doors	1 3/32	1 3/32	15/16	36	Not Available						
7/0 U4 Doors				40							
8/0 U4 Doors	3 15/16	1 3/32	15/16	42	12 1/2		Not Required Wide Lock Stile See Column "A"	3 15/32	4 1/32	28 5/8	
8/0 U4 Flush Glazed and Molded Open Doors					Not Available						
<b>Profiles And Traditions Steel</b>											
6/8 U4 Doors					36	12 1/2	12 1/2	3 25/32	3 25/32	3 7/8	24
6/8 U4 Doors	1 5/32	1 5/32	7/8	36	Not Available						
7/0 U4 Doors				40							
8/0 U4 Traditions Doors				42			Not Available	24			

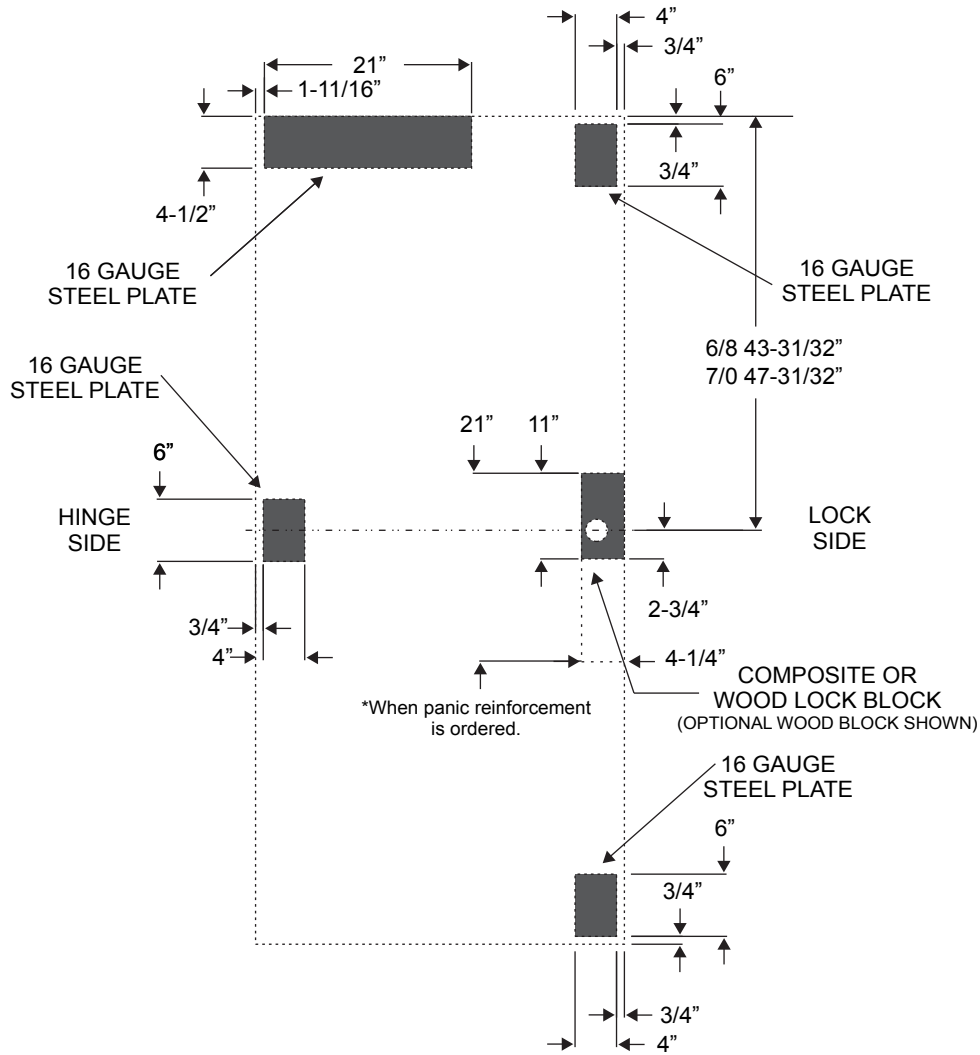

Shaded areas are extra-cost options.

# Door Slab Trimming

Maximum height and width trims for doors.

Standard Doors <sup>a</sup>	A Top Rail	B Bottom Rail	C Hinge Stile	D Lock Stile
Classic-Craft	1-1/4"	1-1/4"	1/32" <sup>b</sup>	1/32" <sup>b</sup>
Fiber-Classic	1/4"	1/4"	1/32"	1/32"
Smooth-Star	1/4"	1/4"	1/32"	1/32"
Steel Doors	1/4"	1/4"	1/16"	1/16"

<sup>a</sup> Standard doors requiring structural product approval or certification cannot be trimmed.

<sup>b</sup> Inspect corners to verify hardwood thickness before trimming.

Impact Doors	A Top Rail	B Bottom Rail	C Hinge Stile	D Lock Stile			
Classic-Craft	1"	1"	N/A	N/A			
Fiber-Classic	N/A	N/A	N/A	N/A			
Smooth-Star	N/A	N/A </tr <tr> <td>Steel Doors<sup>c</sup></td> <td>N/A</td> <td>N/A</td> <td>N/A</td> <td>N/A</td> </tr>	Steel Doors <sup>c</sup>	N/A	N/A	N/A	N/A
Steel Doors <sup>c</sup>	N/A	N/A	N/A	N/A			

<sup>c</sup> Standard steel doors are impact-rated, but cannot be trimmed when requiring an impact product approval, see re-sizing section.

Fire Rated Doors	A Top Rail	B Bottom Rail	C Hinge Stile	D Lock Stile
Classic-Craft <sup>d</sup>	N/A	3/4"	1/32"	1/32"
Fiber-Classic <sup>d</sup>	N/A	1/4"	1/32"	1/32"
Smooth-Star <sup>d</sup>	N/A	1/4"	1/32"	1/32"
Steel Doors <sup>e</sup>	N/A	N/A	1/16"	1/16"

<sup>d</sup> Fiberglass 20-minute positive pressure fire doors can only be trimmed by Warnock-Hersey or NAMI certified re-machiners.

<sup>e</sup> Standard wood-edge steel doors may be fire-rated (if appropriately labeled), but cannot be trimmed in height when being used as a fire door, see re-sizing section. 90-minute steel edge fire doors cannot be trimmed, see 90-minute fire door re-sizing section.

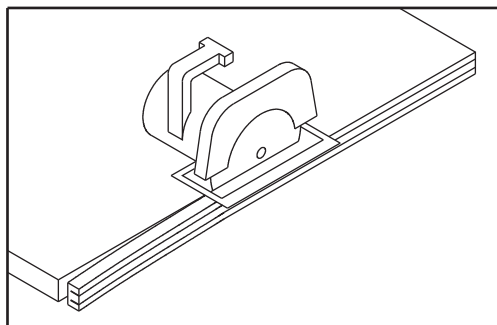
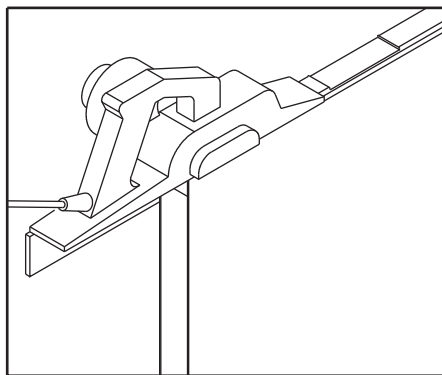
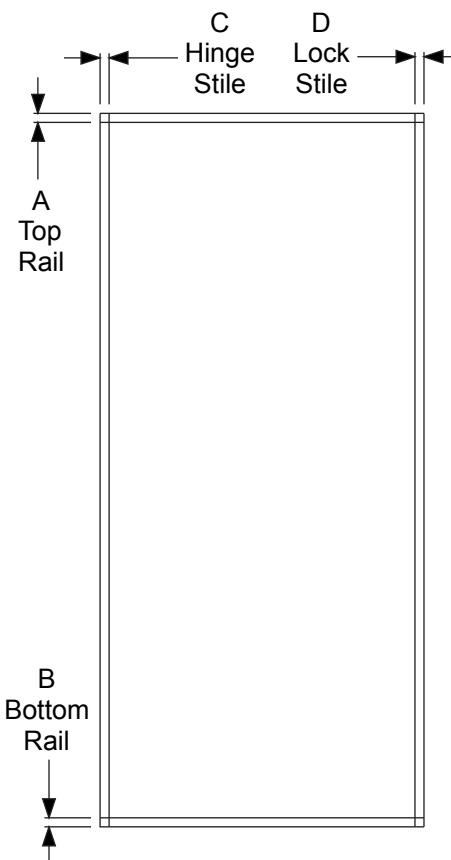

## Trim Slab to Width

- Set planer cutting depth.
- Plane edges of slab.
- Sand smooth if required.
- Paint with primer if required to match original finish.

## Trim Slab to Height

- Measure and mark door slab.
- Cut along line with saw, using carbide-tipped blade. If available, use panel saw.
- Touch up edges with a rasp or sandpaper.
- Trimming the bottom rail may prevent the kerf door bottom from fitting properly. A replacement staple-on door bottom may need to be used.

## Door Slab Resizing Beyond Maximum Trimming Limits



**STOP:**

Fiberglass impact doors and 20-minute fiberglass fire doors cannot be re-sized beyond maximum trimming limits. For 90-minute steel edge fire doors, see 90-minute fire door slab re-sizing section.

### Height Resizing

**Note:**

A standard door can be cut down to any size if it is aesthetically acceptable, the following procedure for re-railing is followed, and it conforms to the applicable code requirements. Flush doors and paneled doors may be re-railed. Any height re-sizing beyond maximum trim limits requires rail replacement. 20-minute steel fire doors can only be resized by a Warnock Hersey certified re-machiner.

### Width Resizing

Doors cannot be edge-trimmed beyond the limits listed in SHOP 3 - Door Slab Trimming

#### **Saw Slab to Length**

Measure and mark door slab.

Cut along line with saw, using carbide-tipped blade. If available, use panel saw.

Touch up edges with rasp or sandpaper.

Note: For 20-minute steel fire doors, a maximum of 6" may be removed from the bottom of the door.

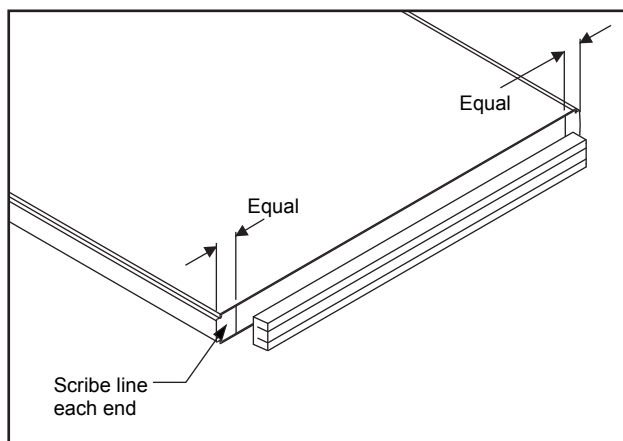
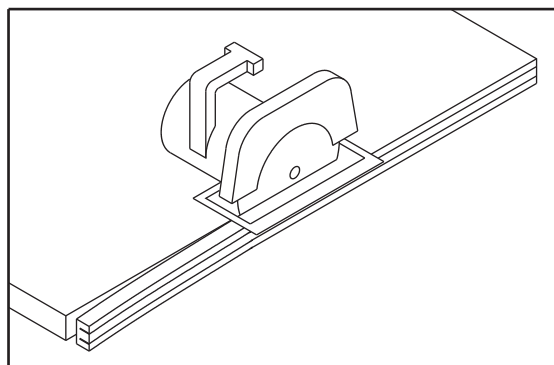

#### **Mark for New Rail Pocket**

Use new rail as a pattern.

Center rail against cut end of door slab.

Scribe at rail ends to mark limits of cut for rail pocket.

# Door Slab Resizing

Door  
Preparation

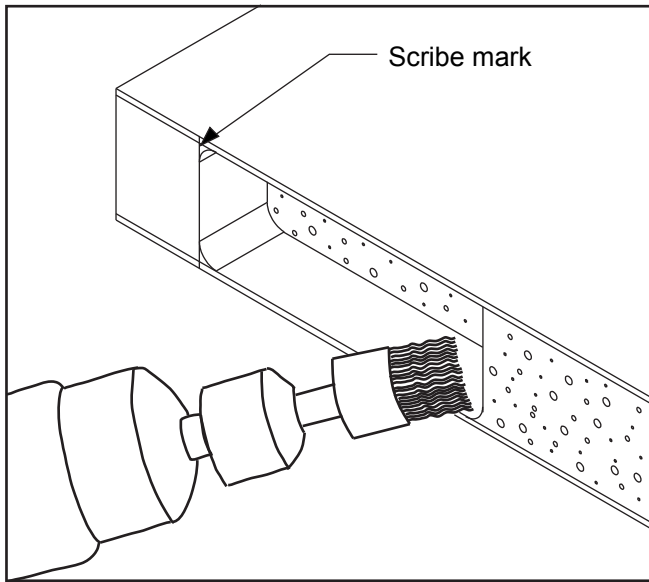

## ***Cut New Rail Pocket***

Remove core material to desired depth using wire brush on a drill.

Cut to scribe marks at ends.

Cut flush to inside skin faces.

## ***Clean Up New Rail Pocket and Test-Fit***

Clean up corners and/or fiberglass skin ribs with a chisel.

Scrape skin faces clean to ensure a good adhesive bond.

Test-fit rail in pocket.

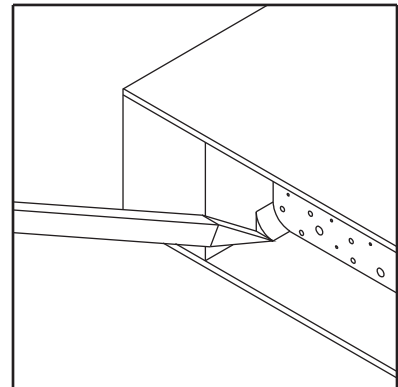



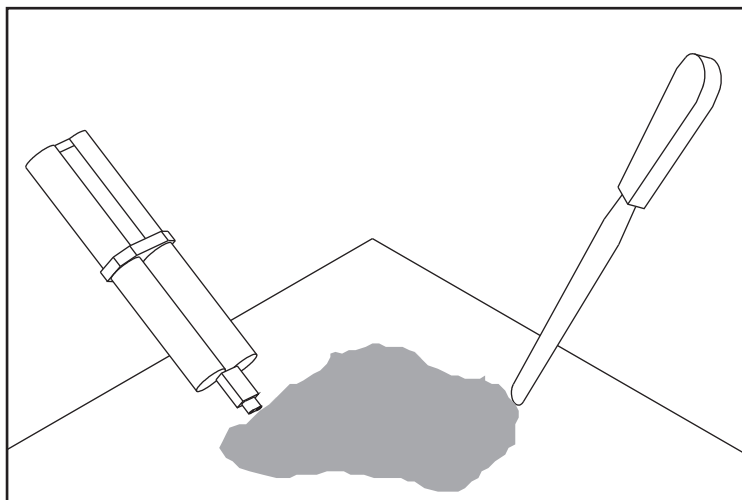

**Mix Adhesive**

Use a fast-setting epoxy.

Mix thoroughly before applying to door skins.

Note: For 20-minute steel fire doors, only adhesive(s) specified in the applicable fire door listing report may be used.

**Apply Adhesive**

Fully coat inside skin surfaces of rail pocket.

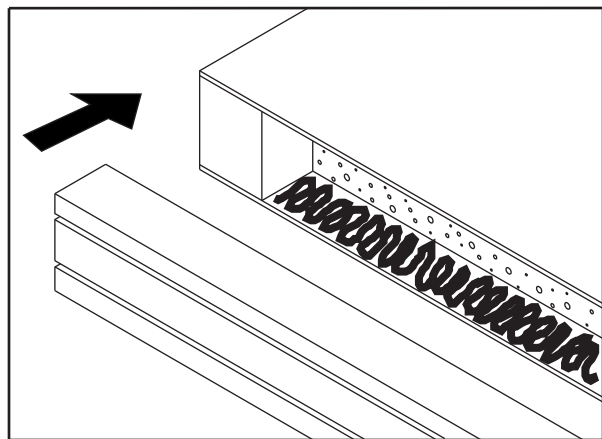
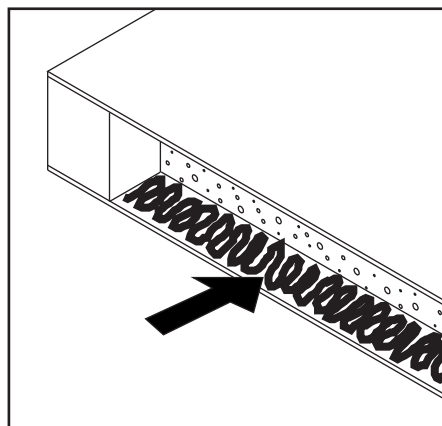

**Insert Rail**

Use plain, no-kerf rails at top of door, or kerfed rail with kerfed edge pointing inward (not showing).

At bottom end, place rail in pocket with kerfed edge facing out.

Note: For 20-minute steel fire doors, only the bottom rail may be replaced. The replacement rail must conform to the specifications in the applicable fire door listing report.

## Door Slab Resizing

Door  
Preparation

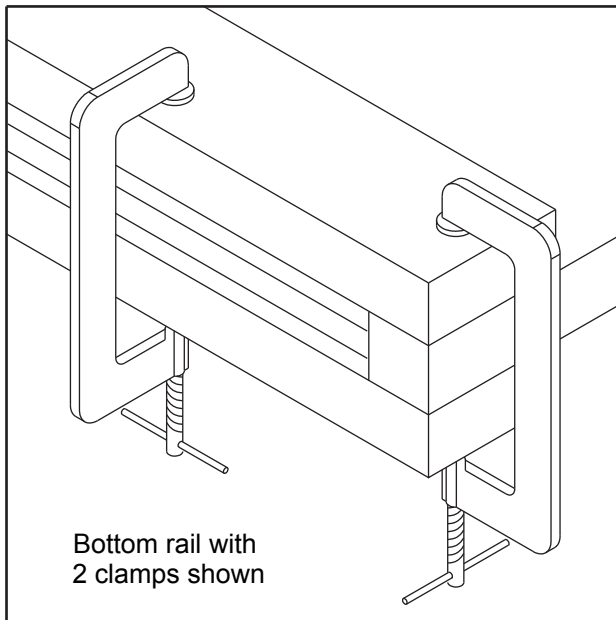

### ***Clamp Assembly***

Clamp to ensure uniform pressure.

Use pad boards to protect slab skins.

Allow to dry per adhesive instructions.



**CAUTION:**

Only shops licensed by Warnock-Hersey as fire door machiners may perform this resizing procedure. These instructions are for reference only. Please refer to the current Warnock-Hersey machining report for the currently approved procedure.

**Method of “Cutting Down” Steel Doors**

NOTE: The maximum total cut down is 4". If the door is to be used in a steel frame, the bottom of the door should be cut off, as it is recommended that steel frames be cut down "from the bottom" when making special height openings. If used in a wood frame, the top of the door can be cut off; the head of the wood frame may be dropped down to fit by cutting down the tops of the side jambs.

**Step #1: Cutting Bottom (or top) of Door**

Cut bottom (or top) of door off to desired length using a saber saw. (See Detail A). Cut one side of door at a time. If saw blade is too long, break off blade so that length of blade does not project more than 1-1/2" on down stroke.

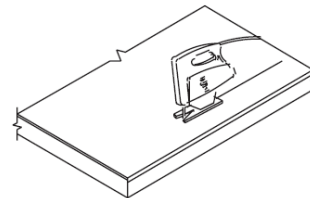

Detail A

**Step #2: Clean Area for Installation of Channel\***

Run an electric drill with 3/16" drill bit along bottom, (or top) of door to remove foam core about 1" deep. (See Detail B). Remove enough core to allow channel to insert between door skin and foam. Thoroughly clean door surfaces that will make contact with tape on channel. A file or sandpaper may be used to clean off foam.

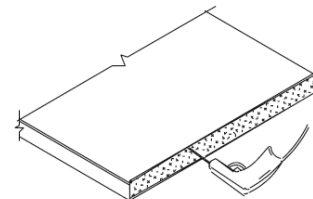

Detail B

NOTE: Foam tape may not stick if surface is not totally cleaned of insulating foam.

**Step #3: Prepare Channel for Installation**

Clean channel with paint thinner and allow to dry. Apply double face tape to both sides of channel. (See Detail C). Peel paper off tape. Channel is now ready for installation.

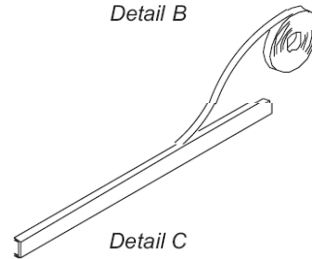

Detail C

**Step #4: Install Channel**

Start by inserting one end of the channel into the door, tight against either the lock or hinge side of the door. (See Detail D). Install remainder of channel. Make sure bottom channel is inserted flush and straight with the cut edge of the door.

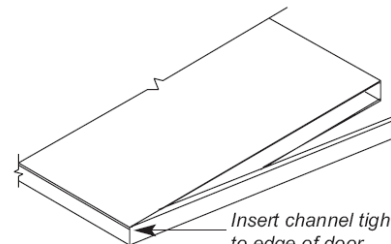

Detail D

**Step #5: Apply Clamps**

Place a wood strip (or equal) on each side of door. Hold strips 1/16" from edge of door. Apply clamps. (See Detail E). Clamps may be removed after a few minutes.

NOTE: Clamp pressure to be firm, not excessive.

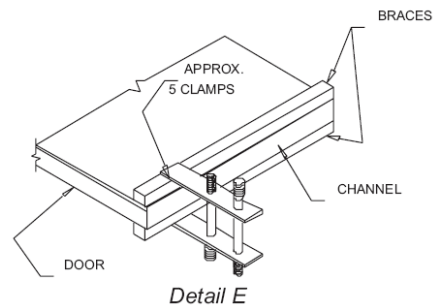

Detail E

\* Top and bottom channels are found in the Components(CPL) section of the Taylor Door Entry Systems Price Manual.

# Slab Repair

## Stile Chips

### ***Fill Chips and Sand Smooth***

Fill minor cosmetic damage to wood stiles with a hardening type wood putty.

File and sand smooth.

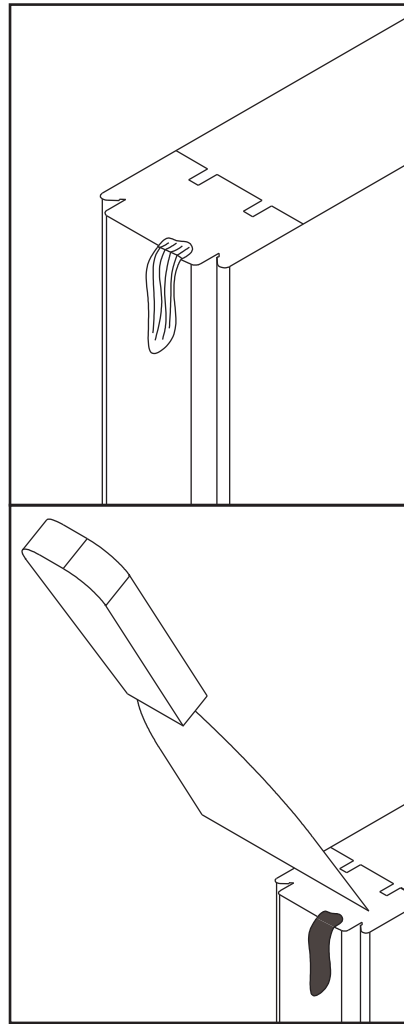

### ***Reprime Area Using Touch-up Paint***

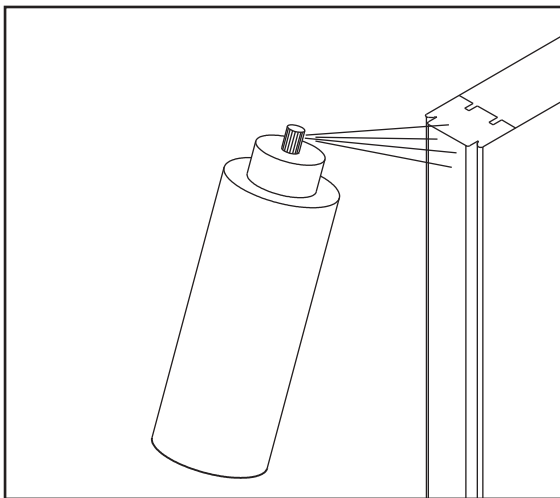

**Steel Door Dent Repair**

***Clean and Roughen Surface***

Clean surface surrounding dent.

Roughen using 100 grit sandpaper.

If possible, do not sand through the existing factory-applied primer.

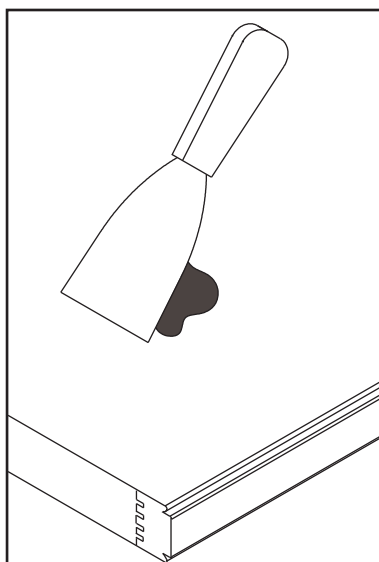
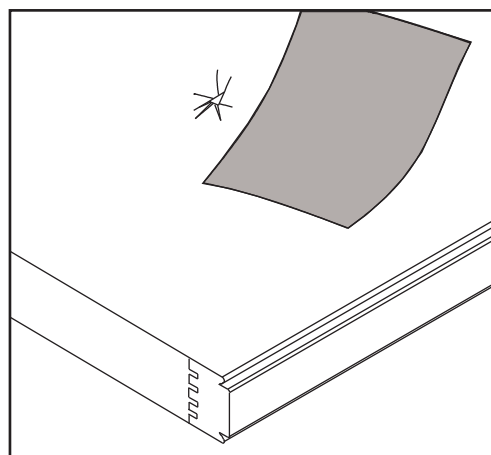

***Fill Dent***

Fill dent using Therma-Tru Dent Repair Kit, (Part Number: MS00DRK), or an automotive body-filler compound.

Smooth using a wide blade putty knife.

Overfill to account for shrinkage and sanding.

***Sand Dent Repair***

Sand repair, using a large sanding block or orbital power sander, with 220 grit sandpaper.

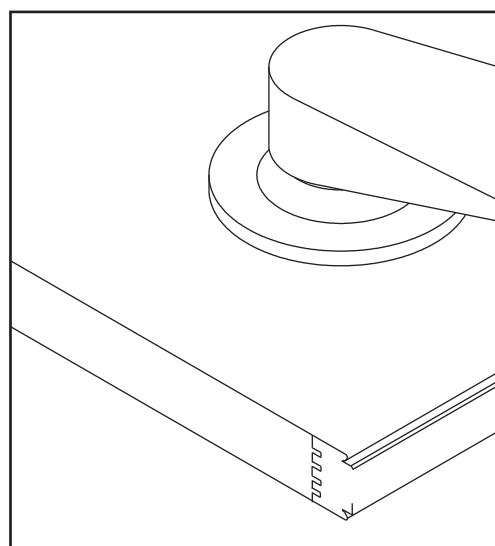

**Steel Door Dent Repair - Cont.**  
**Reprime Repair Area(s)**

If bare metal was exposed, paint entire repair area with a primer containing rust inhibitors.

Reprime repaired area using Therma-Tru touch-up primer. If a rust inhibiting primer was used, let dry thoroughly before applying Therma-Tru touch-up primer.

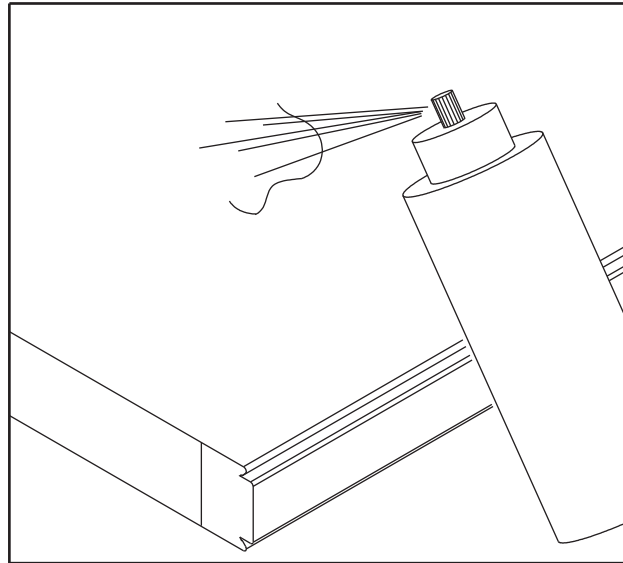

**THERMA-TRU TOUCH-UP PRIMERS**

Description	Part Number
Classic-Craft and Fiber-Classic Primer for Buff skins	MSCCAB-01
Classic-Craft Mahogany Primer for Rose skins	MSCCMAB
Smooth-Star Primer	MSWHSABP-03
Steel White Primer	MSWHABP-01
Steel Edge Door Primer	MSWHSED
Steel Frame Primer	MSWHAF2

**Classic-Craft, Fiber-Classic and Smooth-Star Skin Repair**

- For minor scratches in buff fiberglass skins utilize primer (part #MSCCAB-01) to touch up.
- For minor scratches in rose fiberglass skins utilize primer (part # MSCCMAB) to touch up.
- For minor scratches in white fiberglass skins utilize primer (part # MSWHSABP-03) to touch up.
- For deep scratches, fill with crayon or patch pencil.
- Therma-Tru does not recommend any other repair procedures for composite doors.

**Mark top of hinge mortises.**  
(Index from top edge of door)

ALL DIMENSIONS ARE FROM THE TOP EDGE OF THE DOOR TO TOP OF HINGE MORTISES.

Door  
Preparation

Door Height	Hinge Locations			
	Hinge 1	Hinge 2	Hinge 3	Hinge 4
6/6	8.250	38.000	67.750	N/A
6/8		40.000	71.750	
7/0		33.250	58.750	

Door Height	Adjustable Hinge Locations			
	Hinge 1	Hinge 2	Hinge 3	Hinge 4
6/6	8.525	37.775	67.025	N/A
6/8		30.931	56.431	
7/0		5.431	30.931	

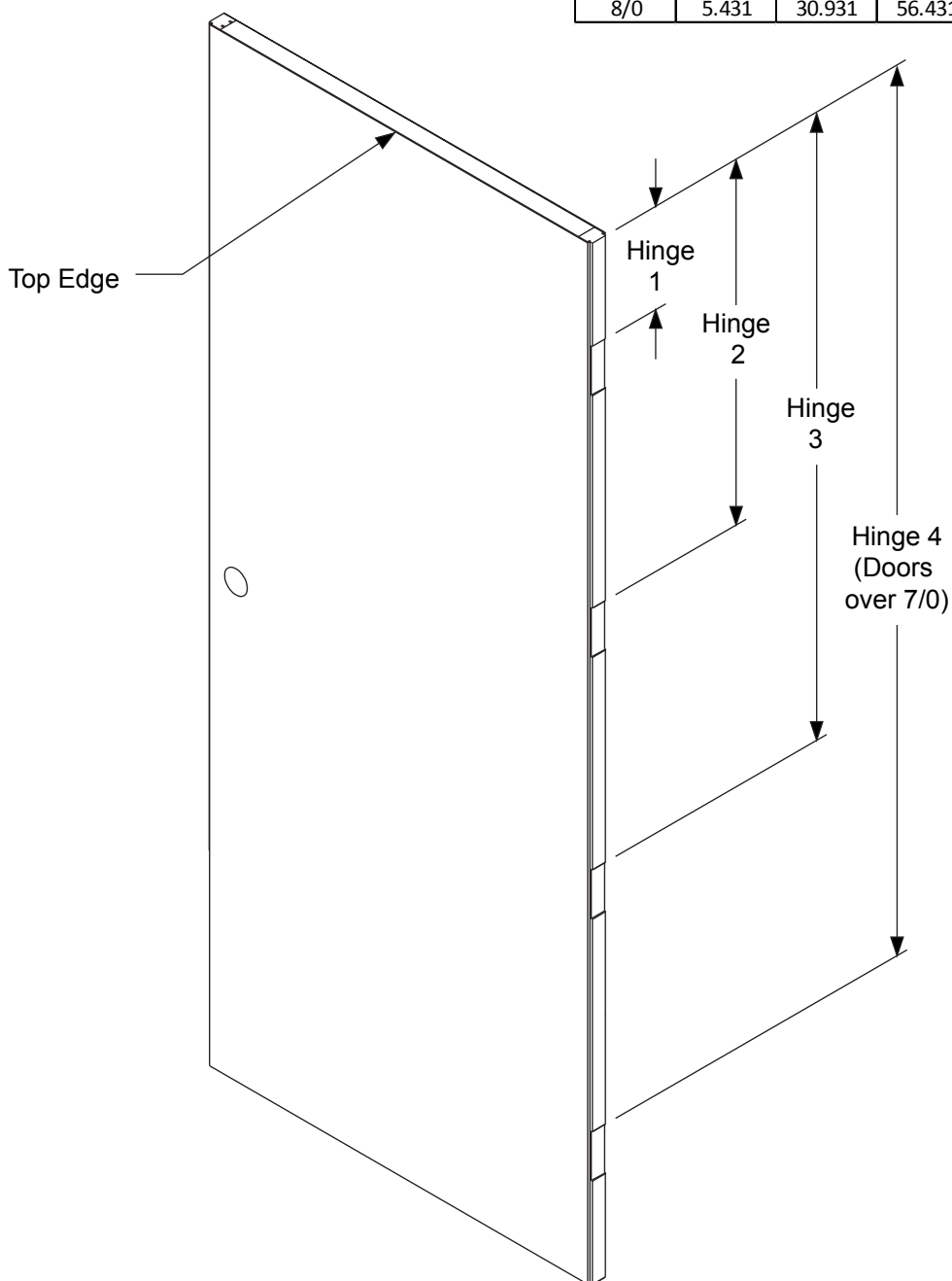

# Hinge Preparation (Except 90 Minute Steel Fire Door)

**Mark bottom of hinge mortises.**  
(Index from bottom edge of door)

Door  
Preparation

Door Height	Hinge Locations			
	Hinge 1	Hinge 2	Hinge 3	Hinge 4
6/8	8.157	35.594	63.032	N/A
8/0	9.282	32.532	55.782	79.032

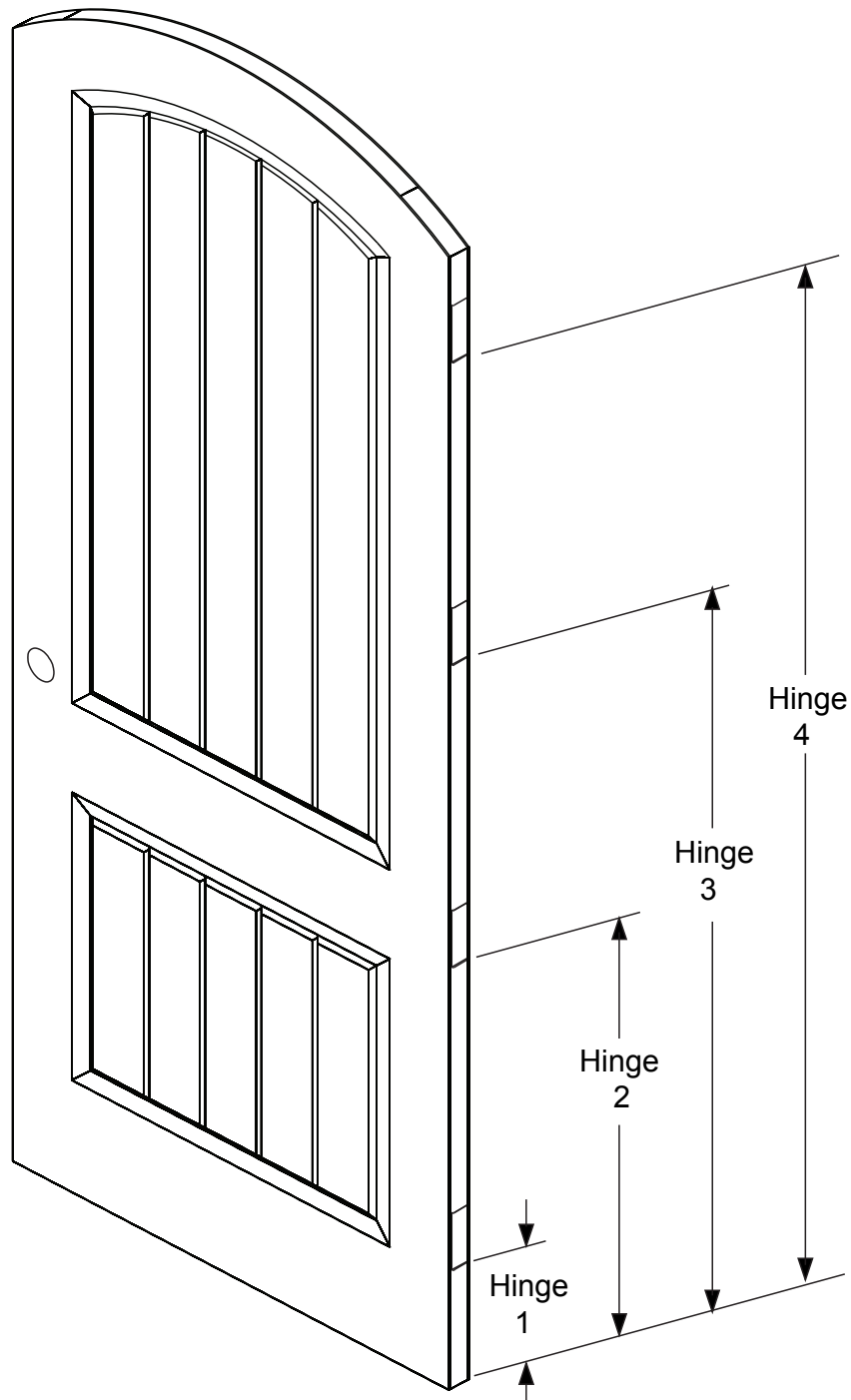



**Mark bottom of hinge mortises.**  
(Index from bottom edge of door)

Door Size	Hinge Locations			
	Hinge 1	Hinge 2	Hinge 3	Hinge 4
3/0 x 6/8	8.157	31.282	54.407	N/A
3/6 x 6/8	7.157	29.282	51.407	
3/0 x 8/0	9.282	29.657	50.032	70.407
3/6 x 8/0		28.657	48.032	67.407

Door  
Preparation

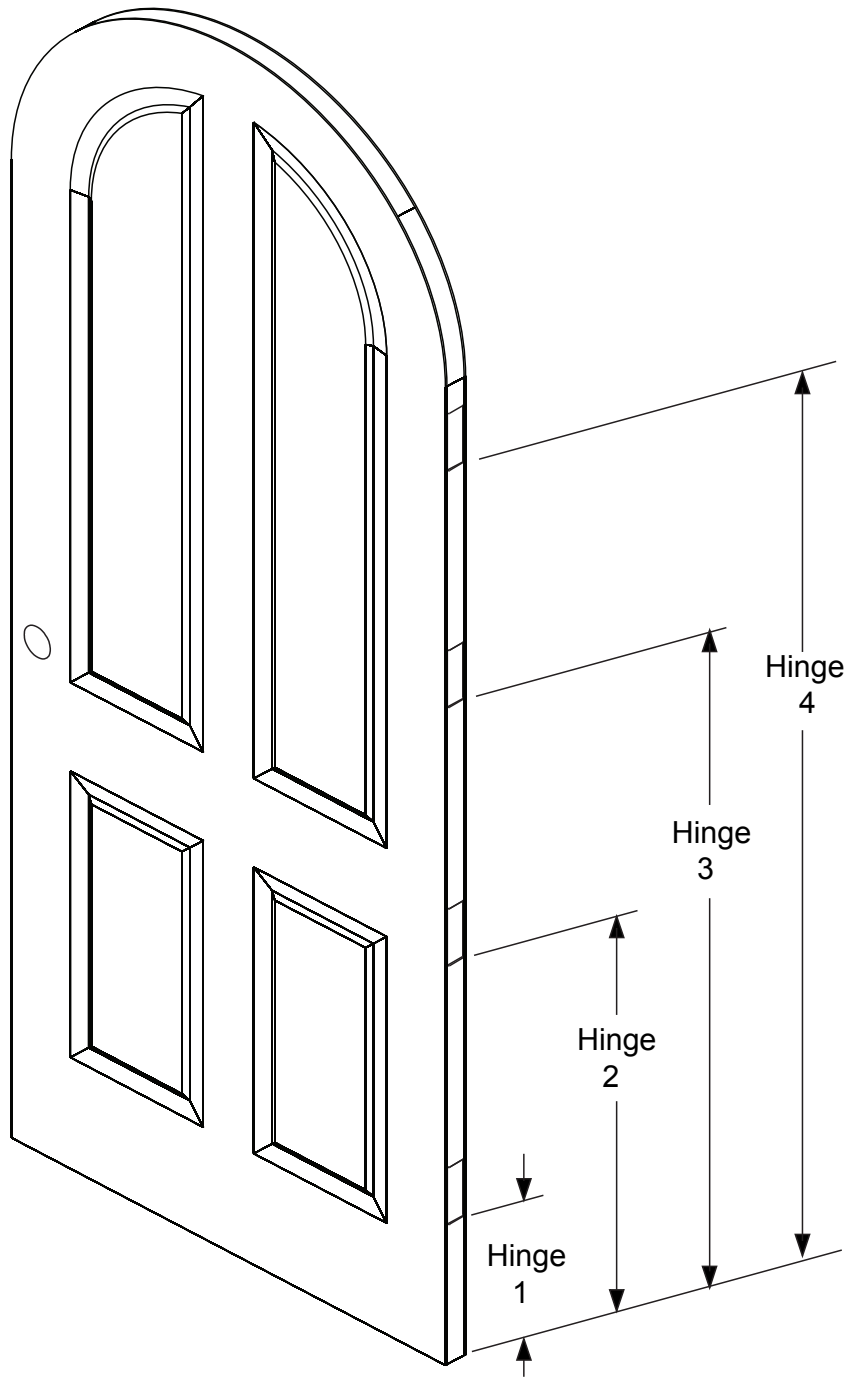

# Hinge Preparation (Except 90 Minute Steel Fire Door)

Door  
Preparation

## Mark and Cut Mortises

Use a special-purpose machine or a router and template.

Pass-Through

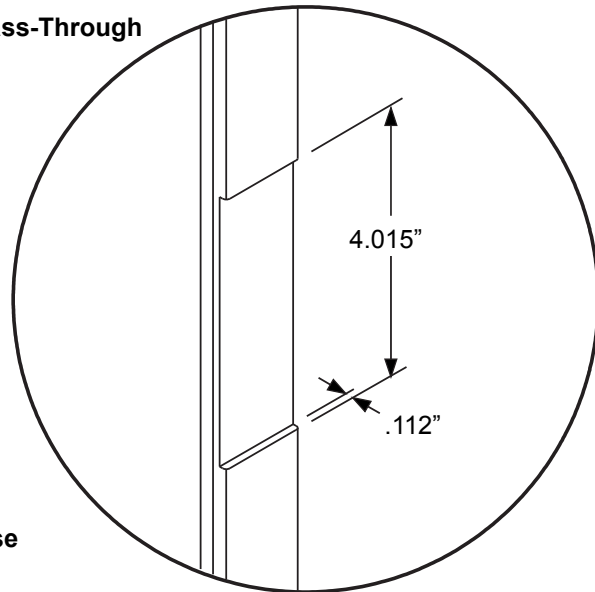

Full Mortise

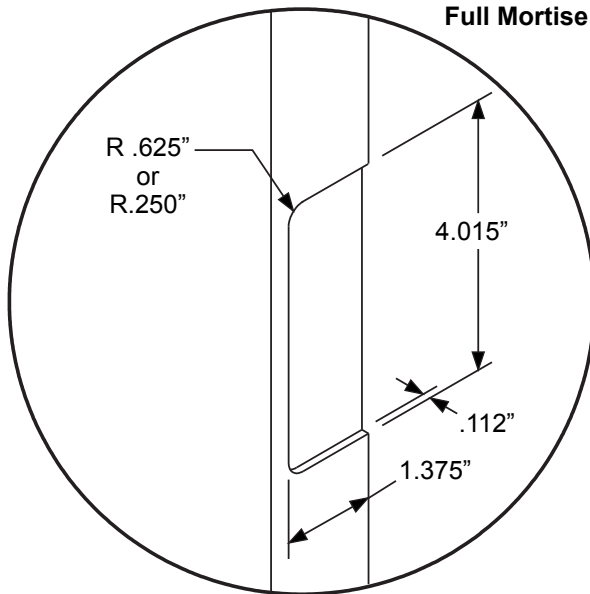

### CAUTION:

Full mortises require pilot holes only if door has hardwood stiles. Refer to Hinge Installation for instructions.

Adjustable

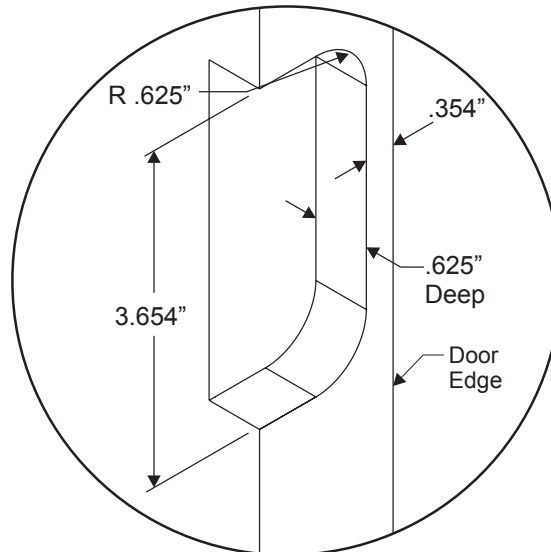

***Adjustable Hinge Machining***

1. Orient panel for proper handing and secure door on edge with hinge stile facing up. Mark the top of the adjustable hinge locations on the edge of the door slab per the Hinge Preparation section.
2. Follow the assembly instructions provided with the jig, then place the jig on the hinge stile of the door slab. (Do not clamp door yet.)
3. Place the L-bracket piece over the top inside edge of the template and visually align the inside edge of the bracket with the marked hinge location. Clamp jig securely to door, then remove the L-bracket piece.
4. Using a 1/2" bit and a 13/16" guide collar, set the depth stop on the plunge router to machine the adjustable hinge pocket depth as specified in the Hinge Preparation section. (Machine in multiple passes to achieve final depth.)
5. Repeat steps 3-4 for the remaining hinge locations.

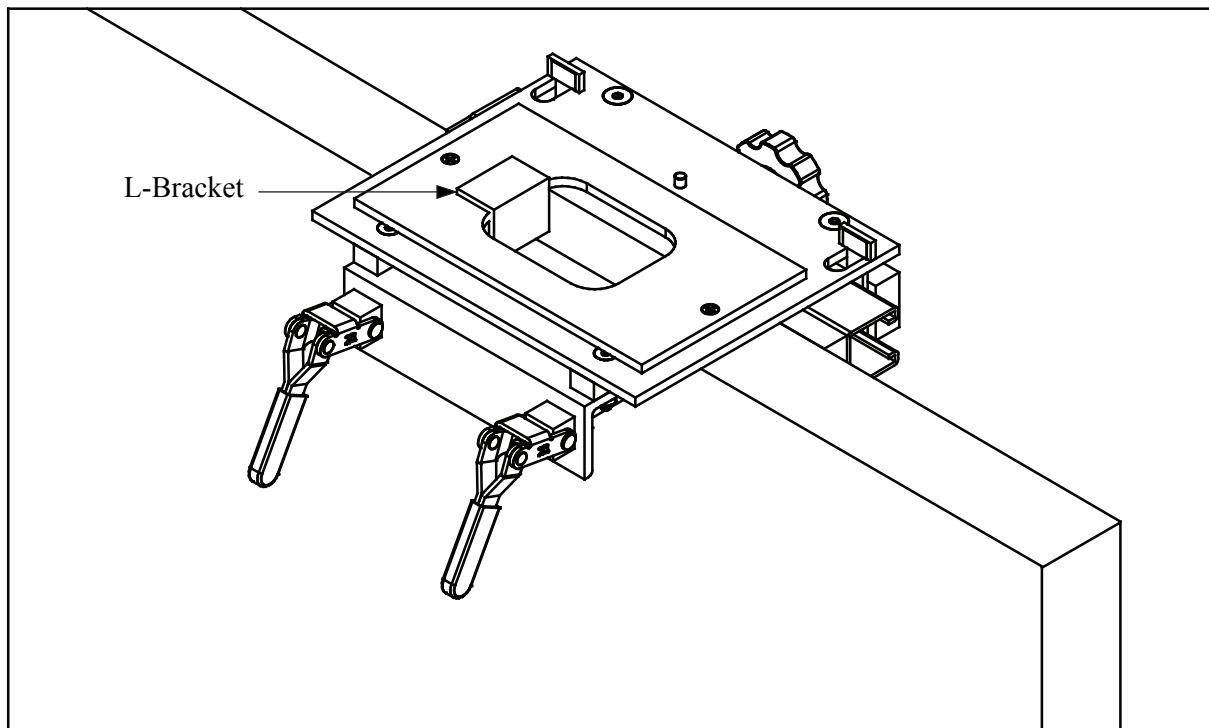

# Lock Preparation (Except 90 Minute Steel Fire Door)

NOTE:  
See 90-Minute Steel  
Fire Door Lock Preparation.

## Mark for Lock Preparation

Preparation shown is for standard cylindrical lock sets.  
For mortise locks and other types use manufacturer's  
templates and instructions.



**CAUTION:**  
Due to stile width and lite placement, some  
door styles have restrictions on lock crossbore  
and backset. Using the DOOR STYLE  
manual, (paperback or web site), see if  
restrictions apply. Deadbolt locations  
and sizes vary.

NOTE:  
If cutting second prep for deadbolt, spacing should be 7"  
maximum for Fiber-Classic, Smooth-Star and Steel doors.  
No restriction applies for Classic-Craft doors.

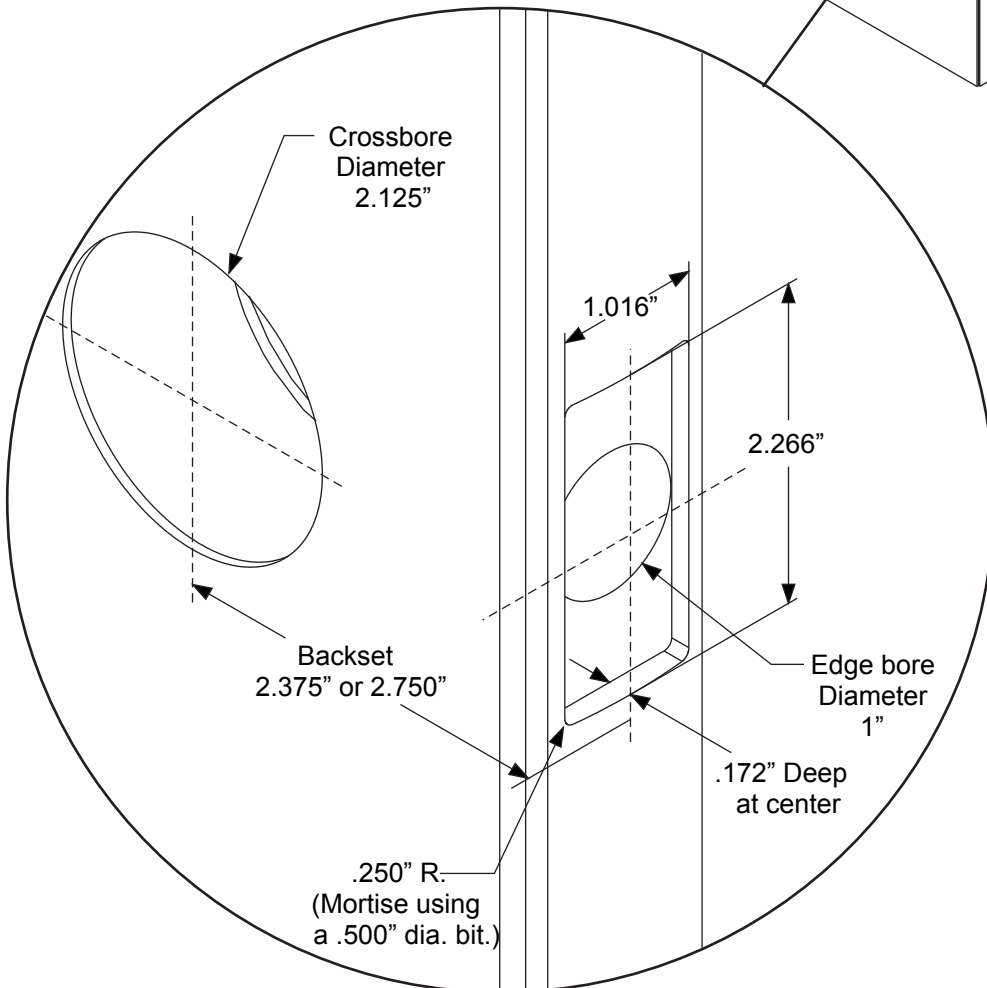
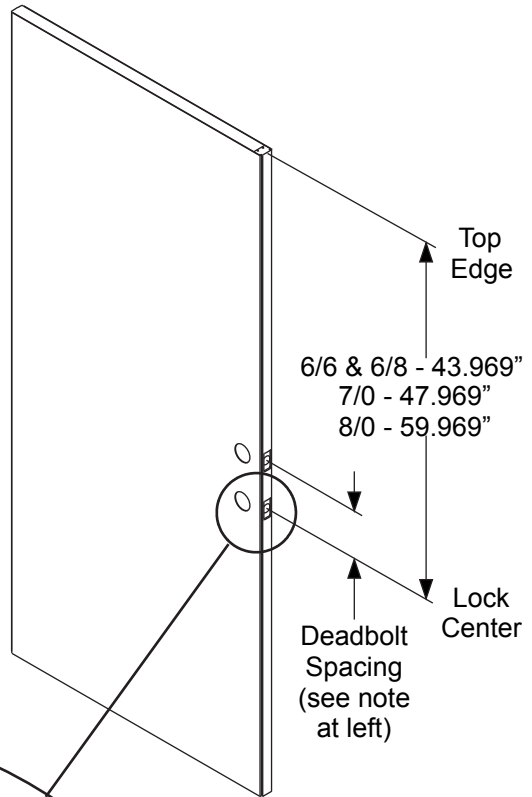

## Drill Crossbore When Door Machine Is Not Available

Bore through half of door thickness until pilot pierces other side.



**CAUTION:**  
Do not bore completely through to other side of door.

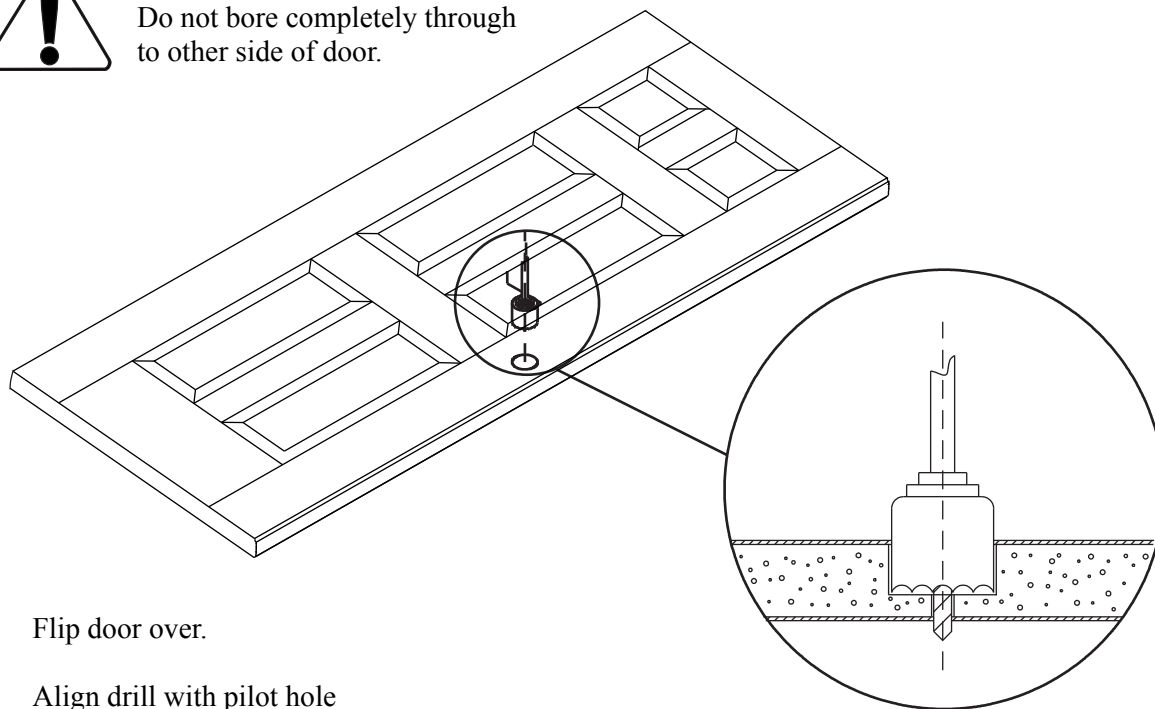

Flip door over.

Align drill with pilot hole and complete boring.

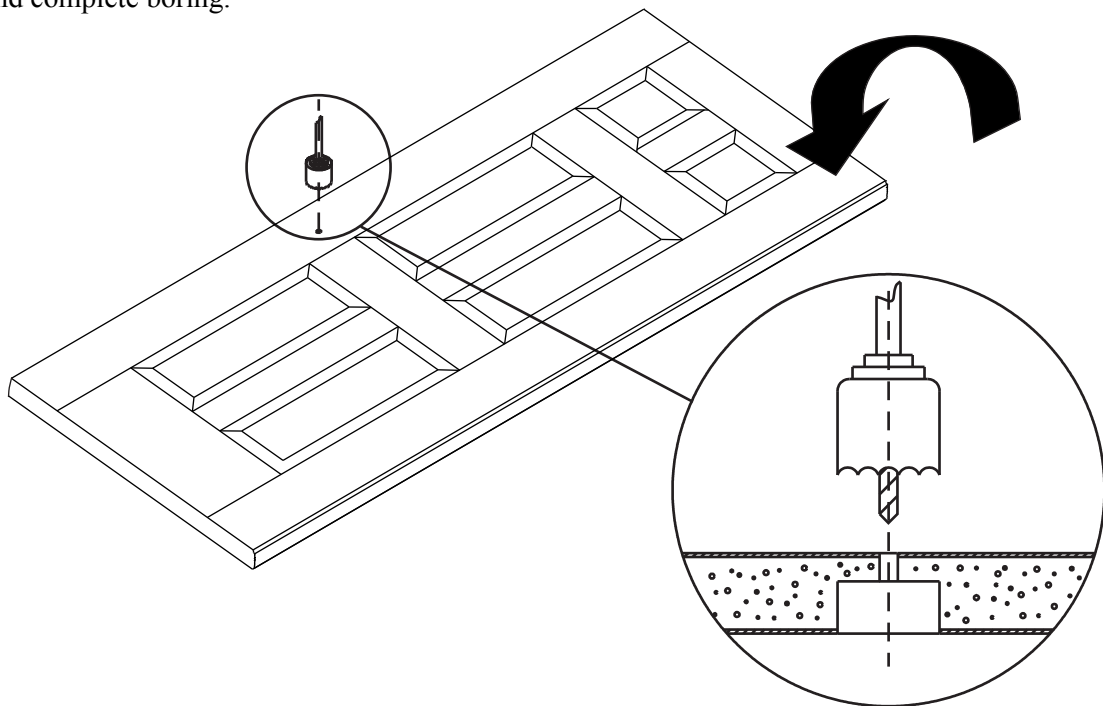

## Mark for Lock Preparation

Preparation shown is for standard cylindrical lock sets. For mortise locks and other types use manufacturer's templates and instructions.



### CAUTION:

Due to stile width and lite placement, some door styles have restrictions on lock crossbore and backset. Using the DOOR STYLE manual, (paperback or web site), see if restrictions apply. Deadbolt locations and sizes vary.

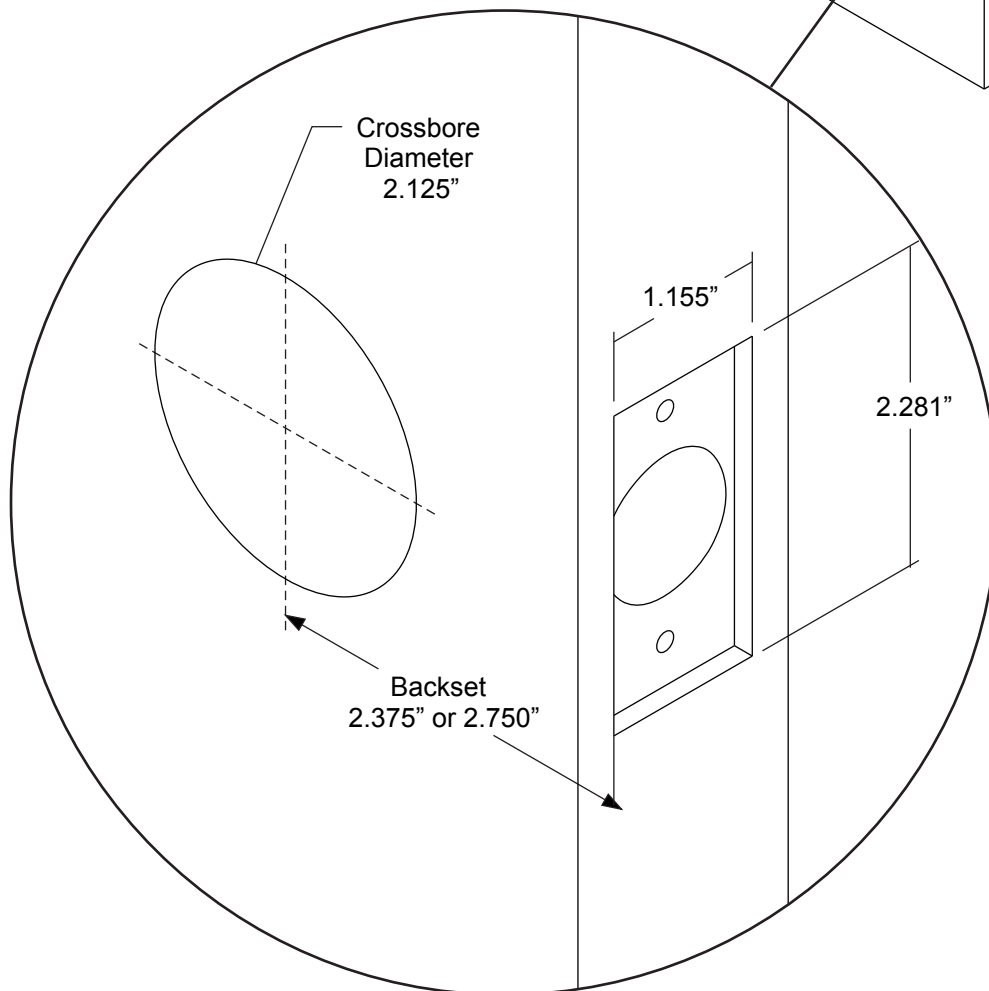
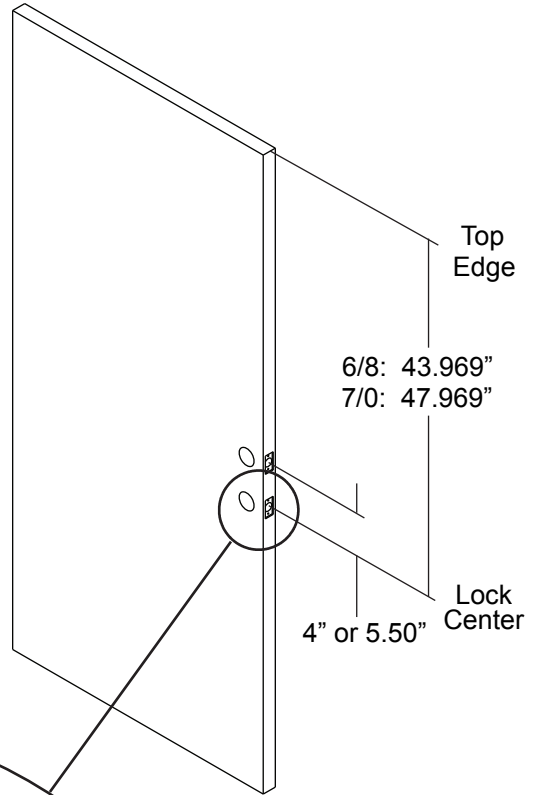



**CAUTION:**

Only shops licensed as fire door machiners may perform this lock preparation.

***Drill Crossbore When Door Machine Is Not Available***

Bore through half of door thickness until pilot pierces other side.



**CAUTION:**

Do not bore completely through to other side of door.

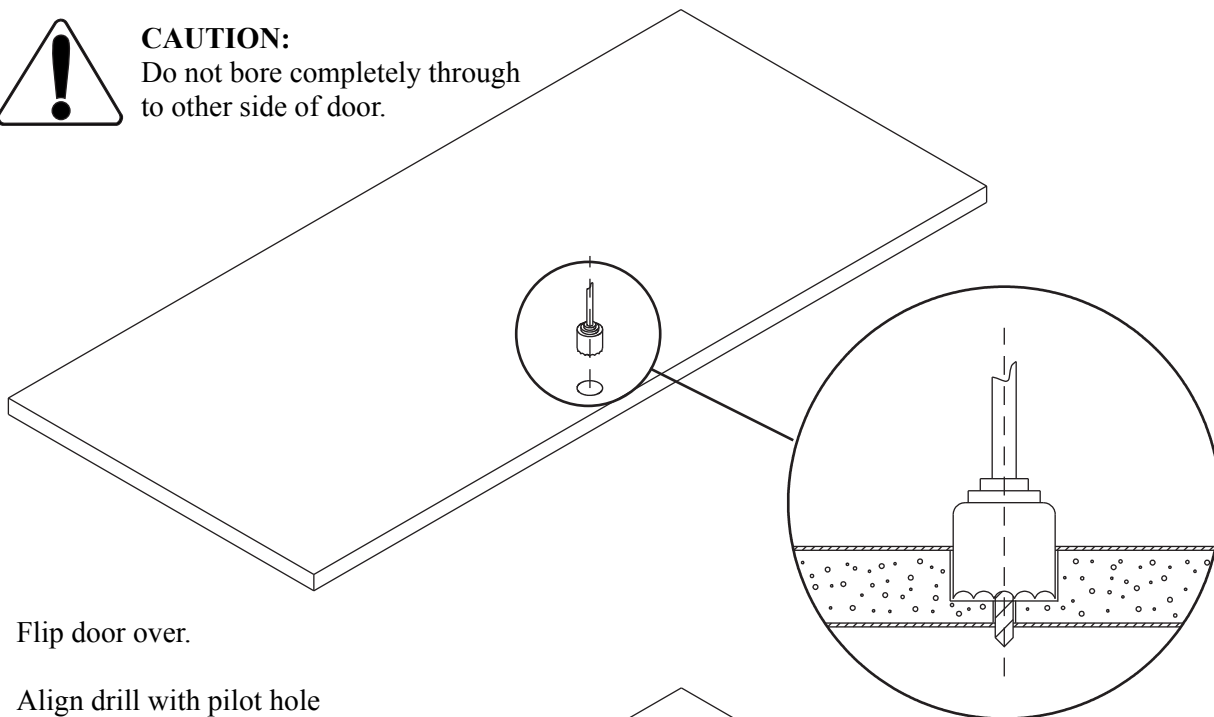

Flip door over.

Align drill with pilot hole and complete boring.

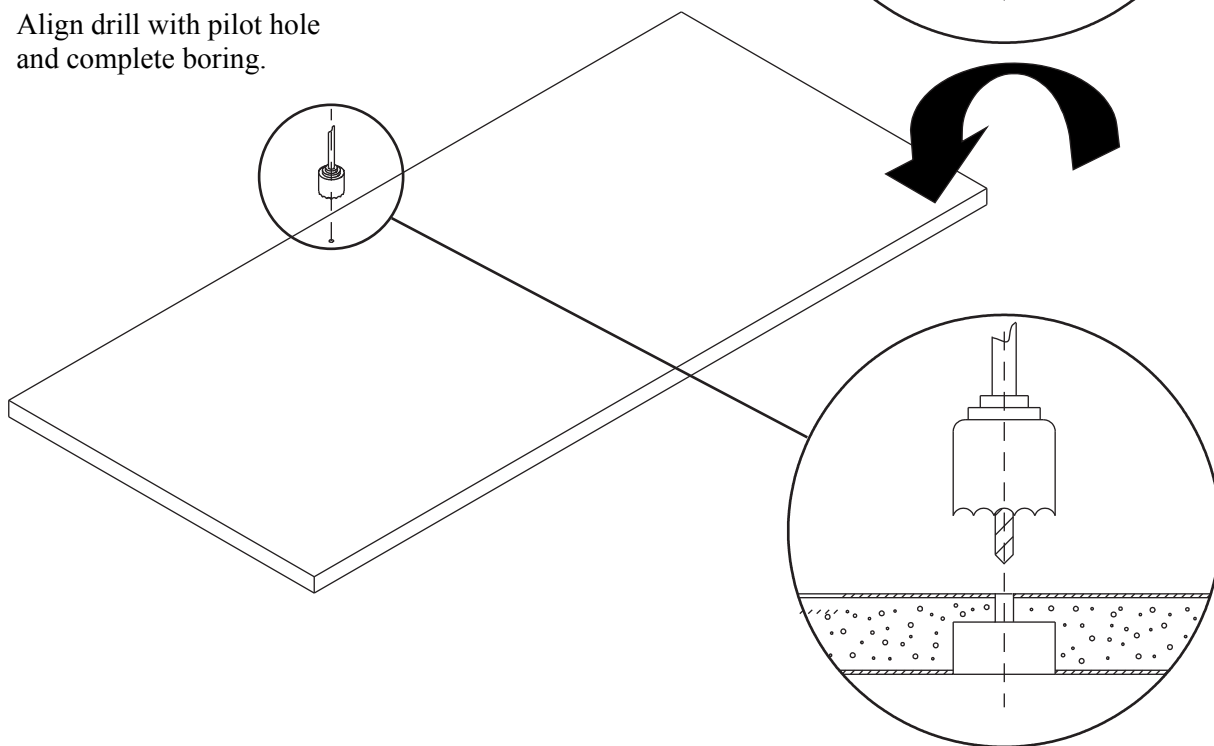

# Multipoint Lock Preparation (Except Fire & Steel Doors)

Door  
Preparation

## Lever Style Multipoint Lock Preparation

Preparation shown is for Therma-Tru multipoint lock set door preparation only. Jamb preparation is shown in individual unit preparation sections. Use this as a reference guide along with the manufacturer's templates and instructions.

**Note:**

Multi-Point Lock Systems recommended only for Fiberglass Products including: Classic-Craft, Fiber-Classic, and Smooth-Star.

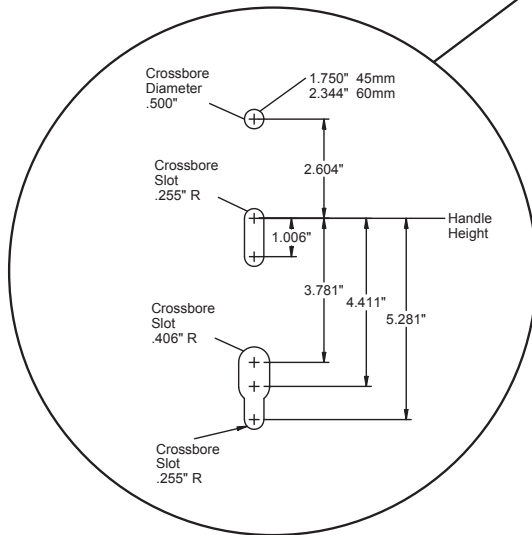
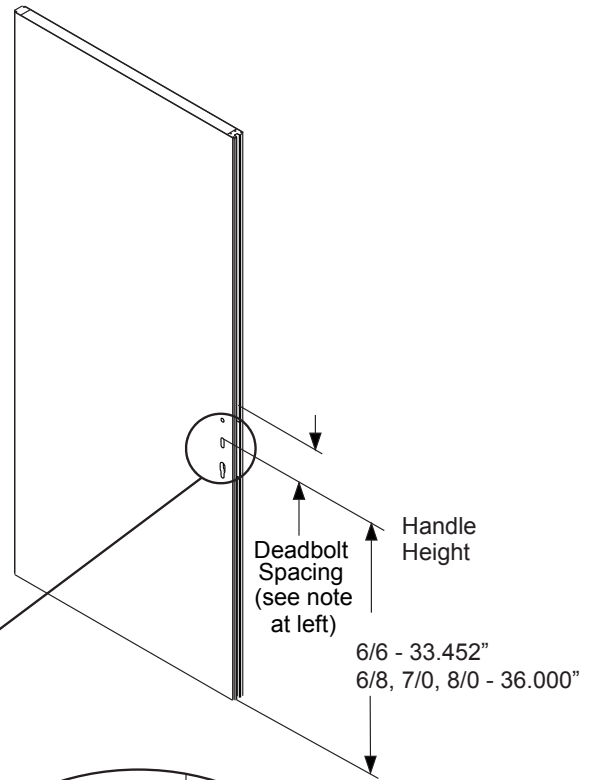

**Lever Style Multipoint Lock Preparation**

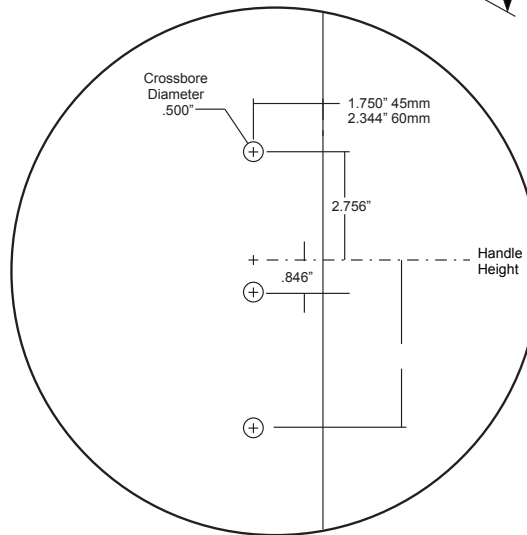

**Lever Style Dummy Lock Preparation**



**Grip Style Multipoint Lock Preparation**

Preparation shown is for Therma-Tru multipoint lock set door preparation only. Jamb preparation is shown in individual unit preparation sections. Use this as a reference guide along with the manufacturer's templates and instructions.

Note:  
Multi-Point Lock Systems recommended only for Fiberglass Products including: Classic-Craft, Fiber-Classic, and Smooth-Star.

Door  
Preparation

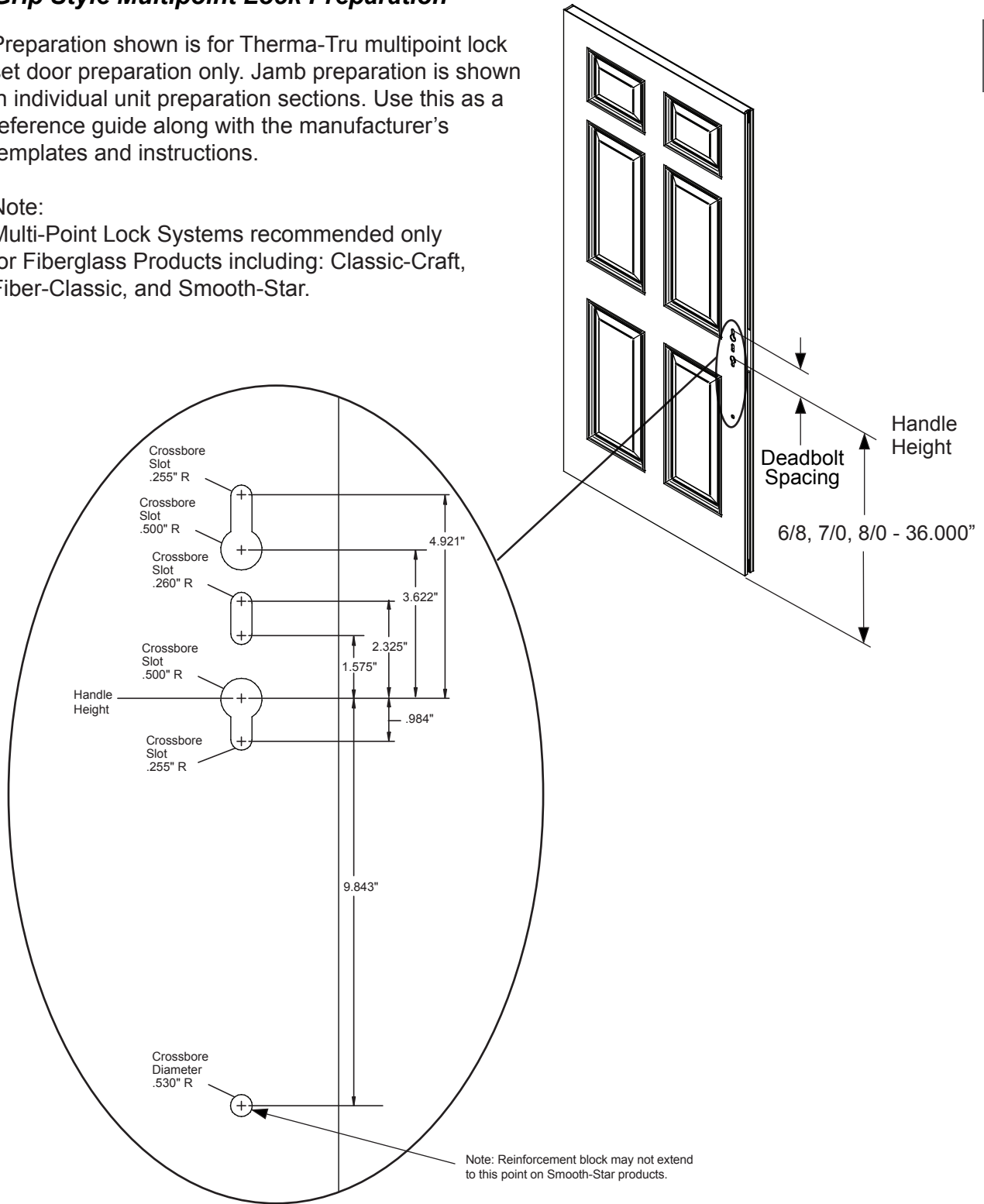

**Grip Style Multipoint Lock Preparation**

## ***Eurogroove Preparation***

### ***Set Router Bit Depth & Adjust Guide Fence***

Set the bit depth using the manufacturer's guide that came with the router. The depth of the route should be 12mm (roughly 15/32").

Note: Test the route depth on a scrap piece of wood.

Adjust the guide fence so that the assembly can slide down the entire length of the door.

Note: If binding occurs, readjust the fence at the thickest section of the door.

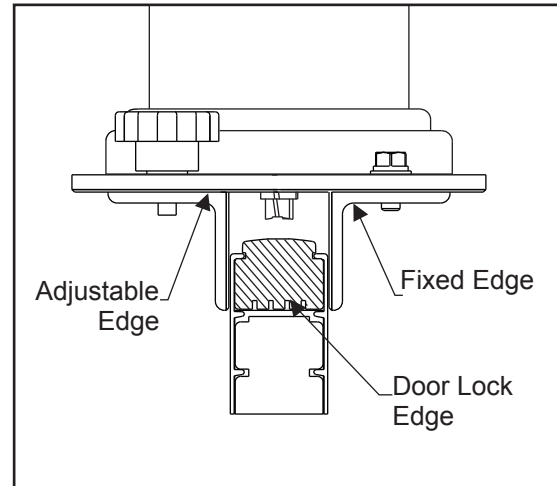

### ***Secure Door on Edge & Apply Router & Guide Fixture***

Set assembly on the door panel and move it until the bit reaches the door edge. Move the assembly away from the door edge so that the bit is not in contact when the router is started.



**CAUTION:** The fixed edge guide for the Eurogroove Router and the fixed edge of the Gear & Handle Mortise Jig must be located on the same side of the door during the preparation. Failure to do so could result in off-center relationship of gear mortise and eurogroove.

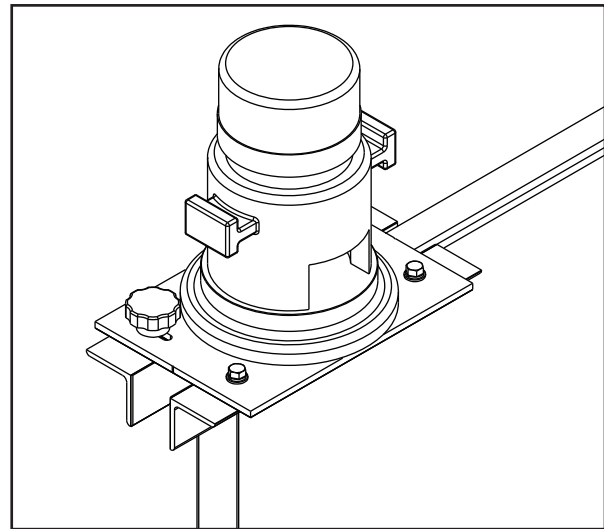

### ***Cut Eurogroove***

NOTE: For best results, set the router at maximum RPM.

Route the entire length of the door edge. Apply constant pressure against the fixed edge of the router fence for best results. Remove the sawdust after the cut is complete.

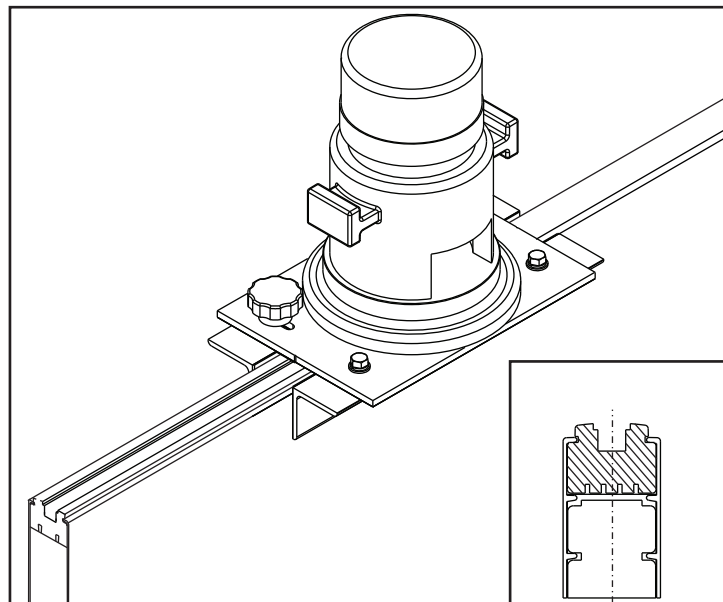

**Gear Mortise Preparation**

**Apply Cross Mortise Fixture**

Set the cross mortise jig on the edge of the door and slide up until the lock height setting bolt has contacted the bottom edge of the panel. Carefully tighten the adjustment knob enough to secure the jig to the panel.

NOTE: Over tightening can cause the width of the mortise pocket to be cut improperly.

NOTE: Be sure the jig is flat against the edge of the panel and tight against the bottom to provide proper placement of the handle mechanism.

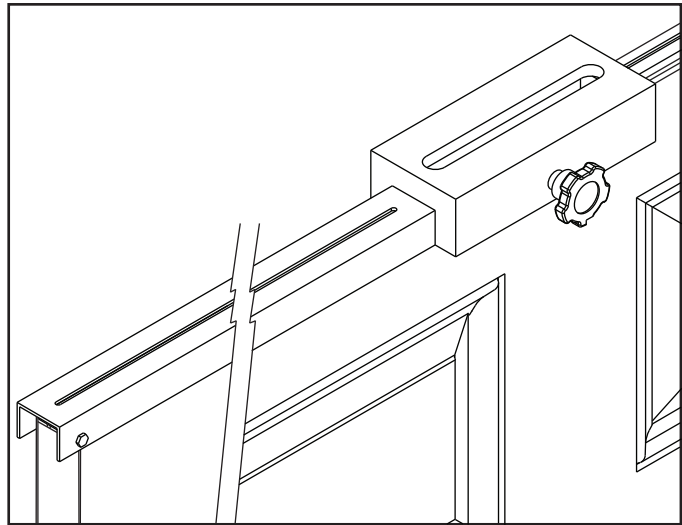

Door  
Preparation

**Set Up Plunge Router**

Set the depth of cut using the manufacturer's guide that came with the plunge router. The depth of the route should be 64mm (approximately 2-9/16" for 45mm & 3-7/32" for 60mm) using a 1/2" cut by 5-1/2" long bit with a 13/16" collar.

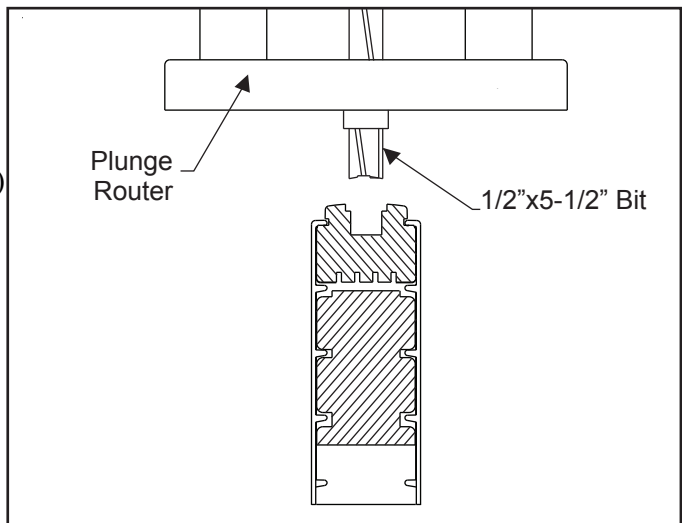

**Cut Gear Mortise**



CAUTION: The router bit will extend past the base of the router. Make sure the router is sitting firmly in the jig before starting the router. Let the router come to a complete stop before removing from the jig.

Slide the bit into the opening on the jig and make cut using several passes along the guide to obtain the proper depth.

Note: It is recommended to cut 1/4" - 1/2" each pass.

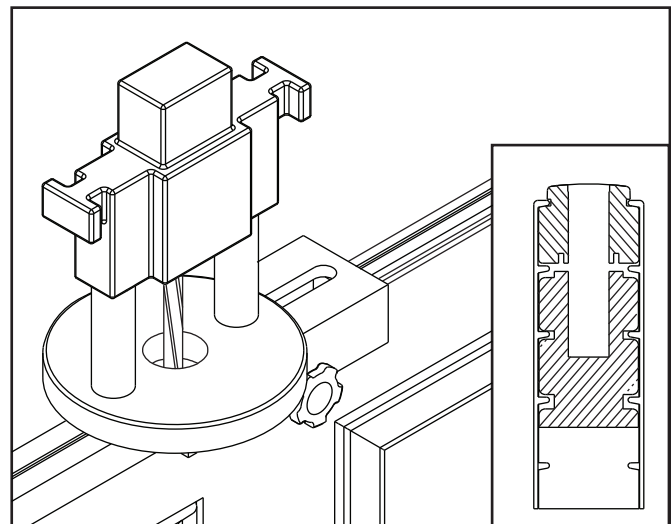

## Lever Style Manual Tongue System

The Lever Style Manual Tongue Bolt system is used for all single and sidelite unit configurations. This system requires a lower gear and a top extension only. The faceplate of these parts is trimmable up to the screw hole above or below the tongue mechanism.

### Lever Style Tongue Bolt Trimming Specifications

Door Slab Height	Gear Part Number	Maximum Trim	Top Extension Part Number	Maximum Trim
(6/6) 76.75" - 64.25"	MPDGARTP	2"	MPARTTE68U	8"
(6/8) 79.25" - 66.75"	MPDGART	4.5"	MPARTTE68U	8"
(7/0) 83.25" - 70.75"	MPDGART	4.5"	MPARTT370U	8"
(8/0) 95.25" - 84.25"	MPDGART	4.5"	MPARTTE80U	6.5"

#### Notes:

1. Trimming of bottom gear will change the handle height on door. Determine the desired handle height before machining for lockset.
2. Trimming of top extension will **not** change handle height on door.
3. The extensions can be trimmed as desired as long as there is a screw hole left beyond the tongue mechanism for secure mounting.

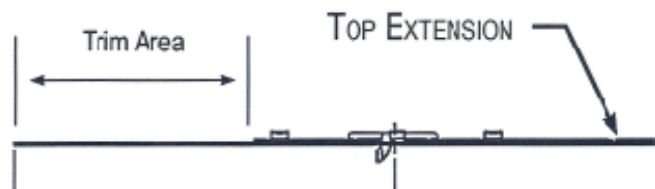

***Grip Style Manual Tongue System***

The Grip Style Manual Tongue system is used for all single and sidelite unit configurations. This system requires a lower gear and a top extension only. The faceplate of these parts is trimmable up to the screw hole above or below the tongue mechanism.

***Grip Style Manual Tongue Trimming Specifications***

Door Slab Height	Gear P/N	Maximum Trim	Top Extension P/N	Maximum Trim
(6/8) 79.25" - 62.75"	MPGSGTG	5"	MPGSGTE68	9"
(7/0) 83.25" - 65.25"	MPGSGTG	5"	MPGSGTE70	13"
(8/0) 95.25" - 82.75"	MPGSGTG	5"	MPGSGTE80	7.5"

Notes:

1. Trimming of bottom gear will change the handle height on door. Determine the desired handle height before machining for lockset.
2. Trimming of top extension will **not** change handle height on door.
3. The extensions can be trimmed as desired as long as there is a screw hole left beyond the tongue mechanism for secure mounting.

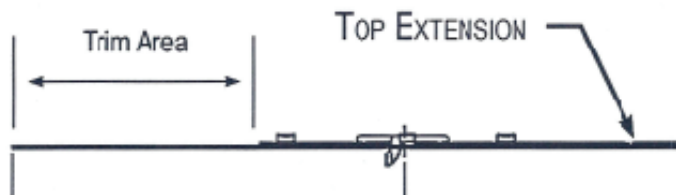

Both the Shootbolt System and the Tongue Bolt systems were designed to be easily modified in height for use with cut down doors. Therma-Tru multi-point lock hardware is made from a weather resistant 300 series stainless steel, so the number of parts you need to modify for production will determine what methods you will use to trim them with.

## Very Low Volume

- Bolt Cutter
- Hack Saw - Carbon steel fine tooth blade
- Grinding Wheel

## Moderate Volume

- Band Saw - High Carbon steel fine tooth blade

## Manual Shootbolt System - Variable Height Option

The Variable Height Shootbolt System is used primarily for double door units. This system requires a middle extension (MPMESB) and a trimmable top extension in addition to a standard Shootbolt system gear. The trimmable top extensions and their usage by door height are listed below.

### Shootbolt System Trimmable Top Extensions

Door Slab	Part Number	Extension Length	Maximum Trim
76.61" - 80.55"	MPTE8611	15.75"	3.94"
82.52" - 86.46"	MPTE8619	21.56"	3.94"
88.43" - 92.36"	MPTE8627	27.56"	3.94"
91.38" - 95.31"	MPTE8631	30.51"	3.94"

Notes:

1. When cutting the top Shootbolt extension, the faceplate must be cut to the exact length as the distance from the top of the door to the middle extension faceplate for a precise connection seam.
2. Make sure to have at least 1.24 inches of serrations left on the drive rail to make a good connection.
3. Be sure to have the end of the drive rail pulled even with the faceplate before cutting the top extension.

See illustration below.

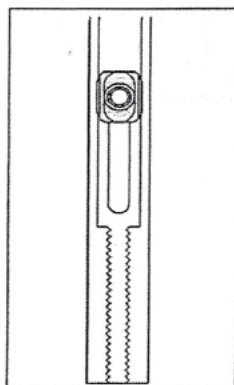

Correct Cut

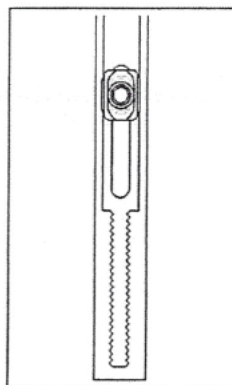

Incorrect Cut

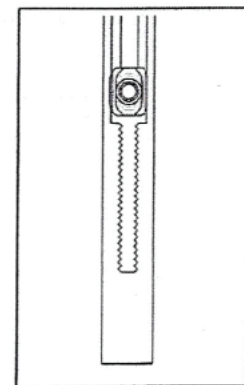

Incorrect Cut

**Trim Set Preparation**

**Cut Trim Set Holes**

Using the same cross mortise jig set up, place the door laying flat on a table to ease this portion. Reset the plunge router bit to allow the guide to rest completely flat on the face of the jig and route all holes through the face of both sides of the door panel.



**CAUTION:** The router bit will extend past the base of the router. Make sure the router is sitting firmly in the jig before starting the router. Let the router come to a complete stop before removing from the jig.

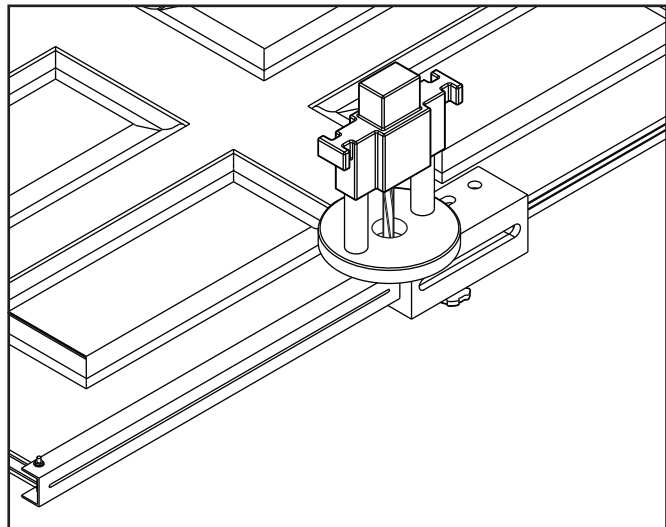
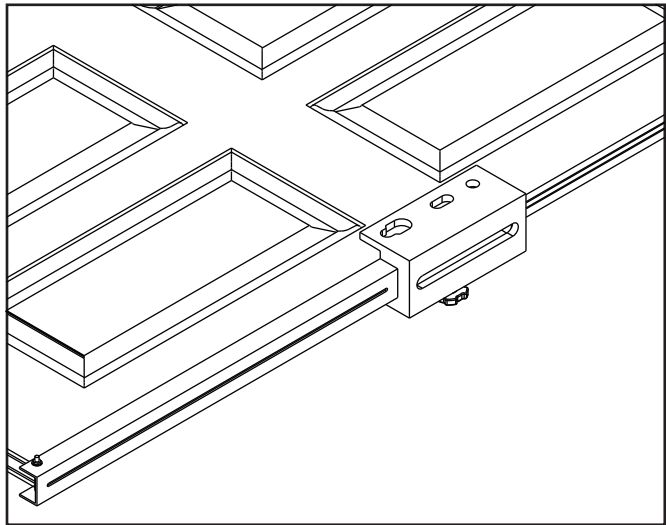

Door  
Preparation

## Step 1- Sidelite Handle/Mortise Jig for the Venting S/L units

Door  
Preparation

### Tools Required:

- Plunge router with 1/2" bit and 13/16" collar (Provided in door kit)
- Drill bit 7/16"
- Drill bit stop (provided)
- 1/8" Hex head wrench

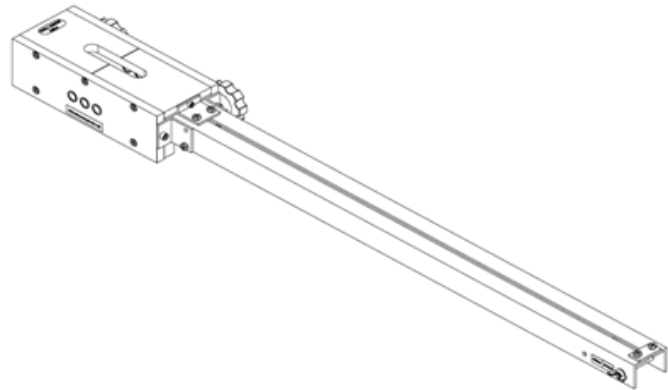

### Power Tool Notes:

**Remember to always follow the safety and operation instructions of the equipment manufacturers.**

Using the information given below, determine the handle position. Place the pin in the hole at the bottom that is marked with the correct handle height. Attach the wing nut to the pin to secure it in place.

Set the router plunge depth to 50.5mm (1.988").

Slide the drill stop over the 7/16" drill bit and then rest the bit on the top of the jig. The bit should extend to a depth of 31.75mm (1.250") or 1-1/4" into the sidelite. Tighten the stop with a 1/8" hex head wrench. Adjust if needed after you first use.

Note: With a sidelite system the thumb turn is on the interior side only. As a safeguard the jig has this instruction etched on the top. Drill from the **interior side only**.

Slide the jig over the lock stile of the sidelite such that the locator pin is resting against the bottom rail.

Ensure the base of the jig is sitting flat on the sidelite. The handle placement arm does not sit on the panel. Do not push down on that since it may tip the base slightly. Turn both black knobs until the jig is firmly clamped to the panel. **Do not over tighten.**

Using the 7/16" drill bit with drill stop, bore the 3 handle holes on the inside surface of the door. **Do not drill all the way through the sidelite.**

Plunge route the top slot to a depth of 33.5mm (1.3") or 1-15/16". For best results, use multiple passes to avoid chipping out the wood.

Remove jig, clean out the saw dust, and install multipoint locking hardware and thumbturn.

UNIT SIZE	HANDLE HEIGHT
6/6	33.452"
6/8, 7/0, 8/0	36.000"



## Step 2 - Sidelite Eurogroove Machining

### Tools Required:

- Eurogroove router  
(Provided in door kit)
- Eurogroove Stops

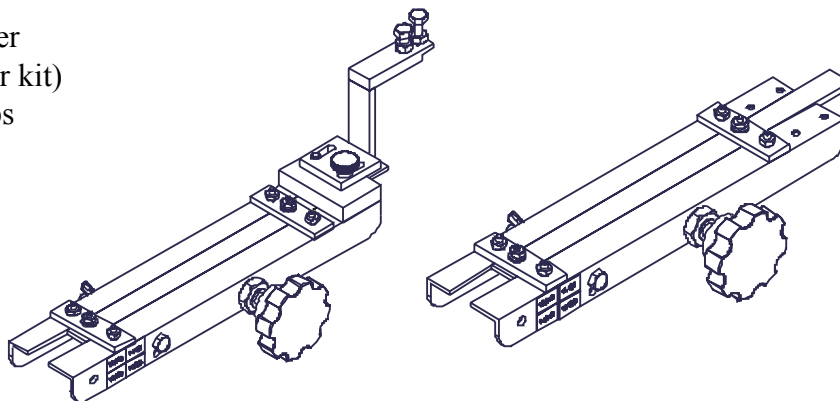

### Power Tool Notes:

**Remember to always follow the safety and operation instructions of the equipment manufacturers**

Using the information provided below, determine the distance from each end that the Eurogroove should stop.

For lengths less than 5", the wing nut is removed from the two piece jig, which is then clamped to the top surface of the sidelite. The two adjustable nuts are then used for the stop locations.

For lengths greater than 5", place the pin with the wing nut in the hole that corresponds with the desired distance. The one piece jig is then clamped to the lock side of the sidelite.

Place the router on the sidelite stile with the bit extending into the hole machined in Step 1. Then machine the Eurogroove, stopping the router when the base plate hits each stop

UNIT SIZE	BOTTOM STOP	TOP STOP
6/6	12.562"	2.394"
6/8	15.110"	2.394"
8/0	15.110"	15.402"

# Classic-Craft Panel Installation

Note: DP300CC used on CC30300 only. DP300CCM used on CCM30300. Temperature range for optimal tape adhesion is 70° to 100°F. Minimum suggested application temperature is 50°F.

Door  
Preparation

- 1. Moisten a clean cloth with 70% Isopropyl Alcohol. Wipe flat surface around entire perimeter of opening. Allow to dry.**



Not preparing door will result in poor panel adhesion.

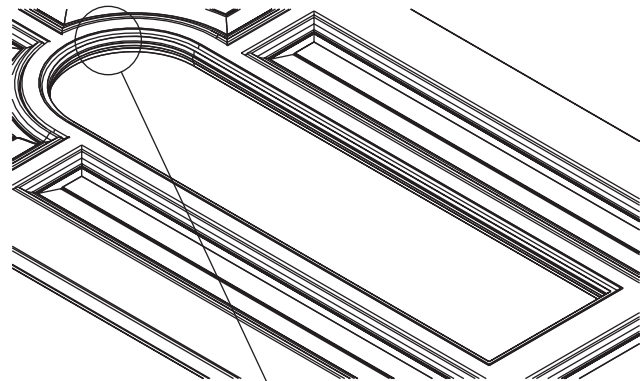

Clean flat surface all around perimeter with alcohol

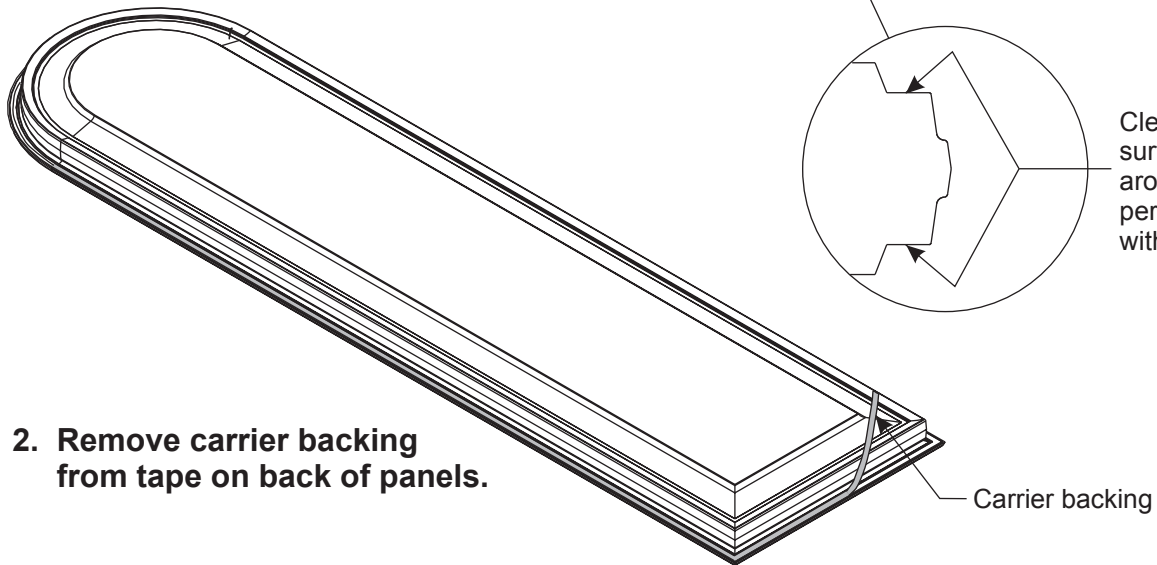

- 2. Remove carrier backing from tape on back of panels.**

- 3. Position panel in opening and press down firmly around outside edges.**

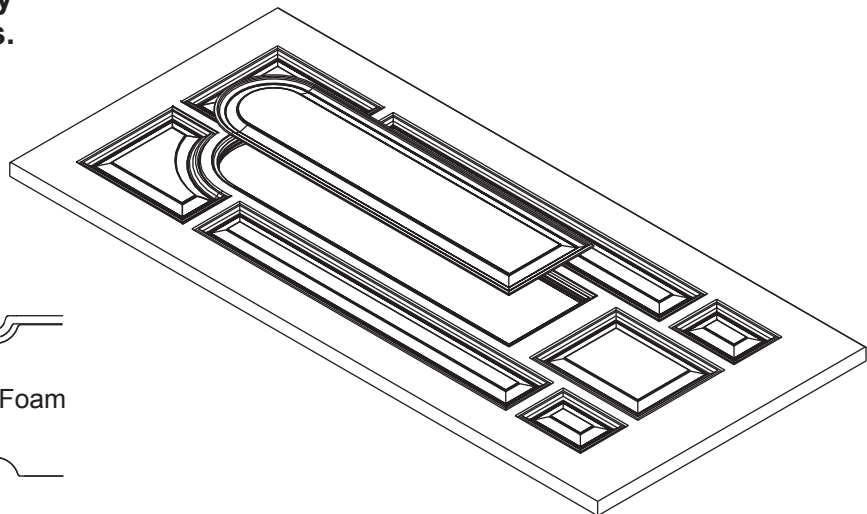
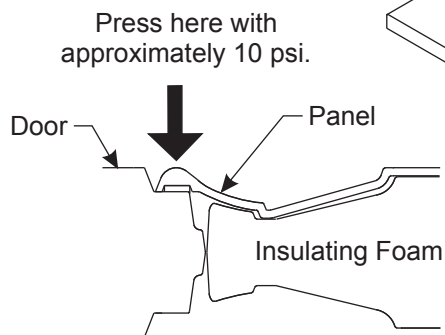

4. Flip door over.
5. Apply two (2) 1/4" - 3/8" beads of structural adhesive to back of panel.

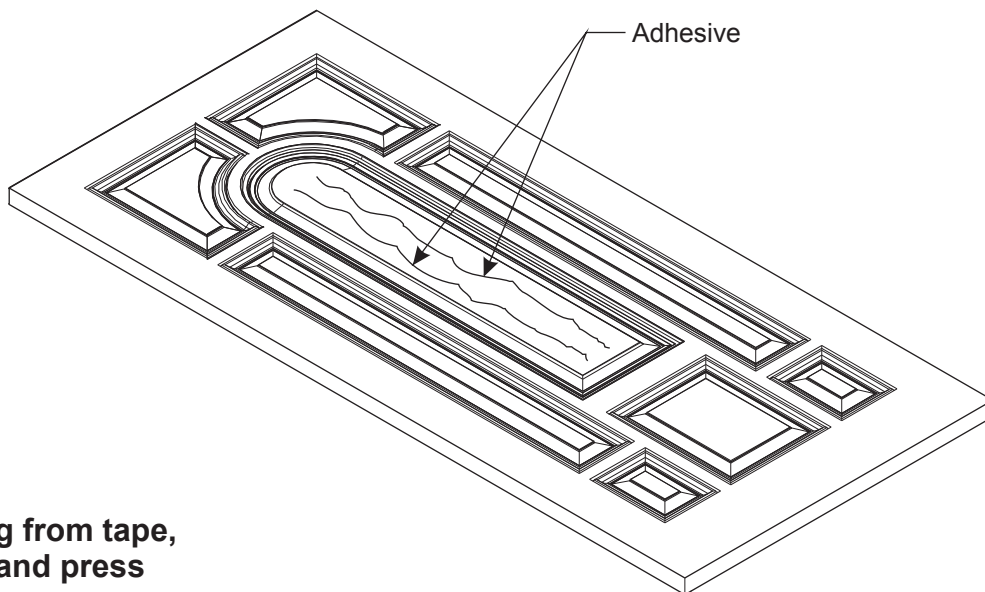

6. Remove backing from tape, position panel, and press firmly into place.

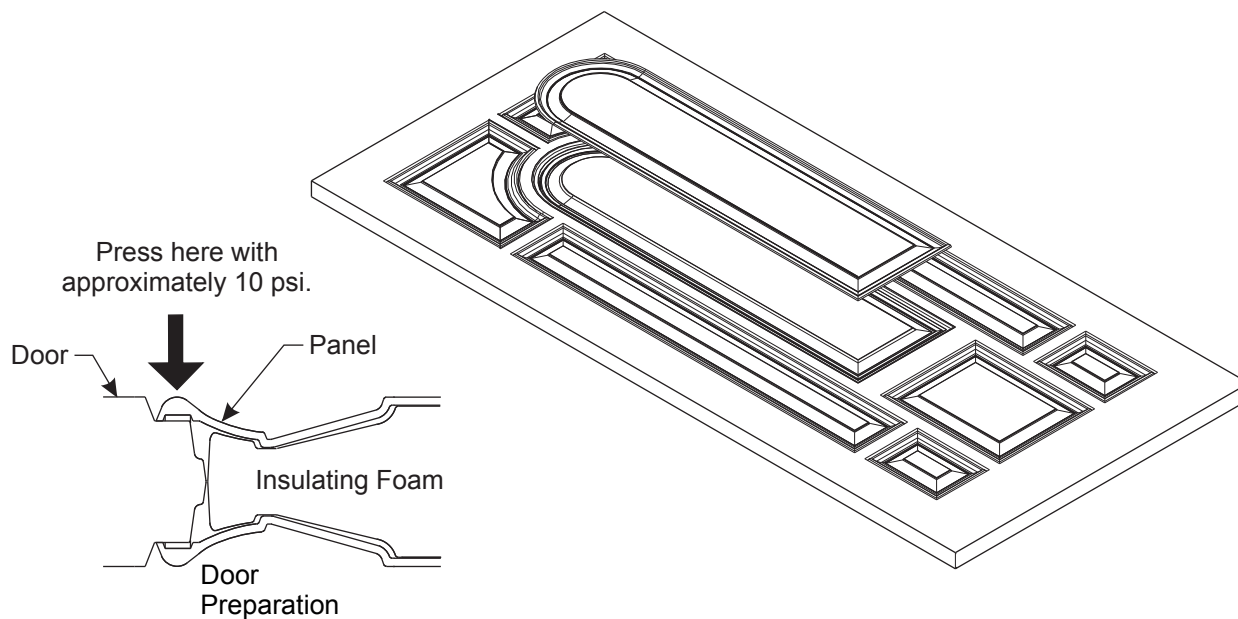

# Doorlite and Panel Preparation

Select the correct template to match the door style. Refer to the Cutout Size Reference section.

Door  
Preparation



**CAUTION:**

If door was resized, template use may be affected. Template location is referenced from the top of the door and embossed pattern adjustments may be necessary. Template may need to be centered from side-to-side.

***Align Template***

Place template on door slab.

Align template with top and edges of door using corners or notches in template.

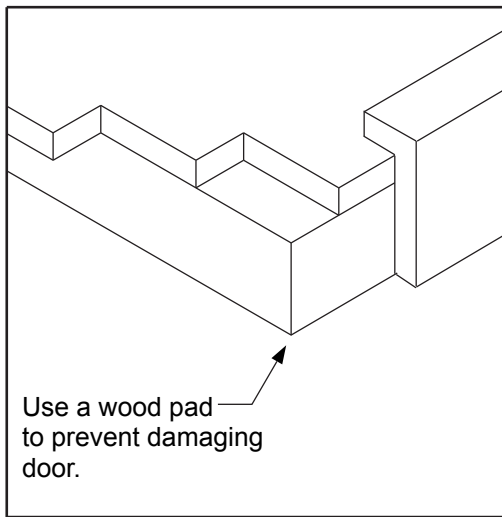
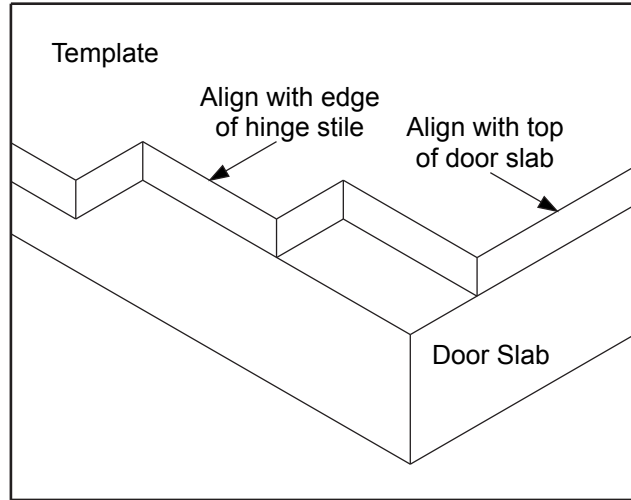

***Clamp Template to Door***

Clamp mechanism and door support table shown here are typical for Ruvo/Triad door cutout machines.

***Cut Slab for Doorlites or Panels***

All templates are designed for use with standard cutout machines. Template openings are offset exactly 1/2" from cutout edges.

Check templates periodically for wear and replace when required. Refer to Door Styles Manual for cutout size specifications.

Modify heavily used templates by adding metal or wear-resistant plastic to edges. Relieve template edges to allow for wear plate thickness.

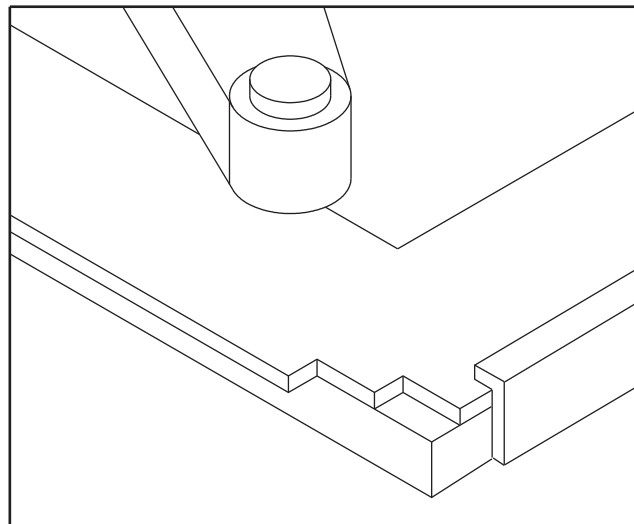
Door  
Preparation



**Always place door in HORIZONTAL position before removing lite or panel.**

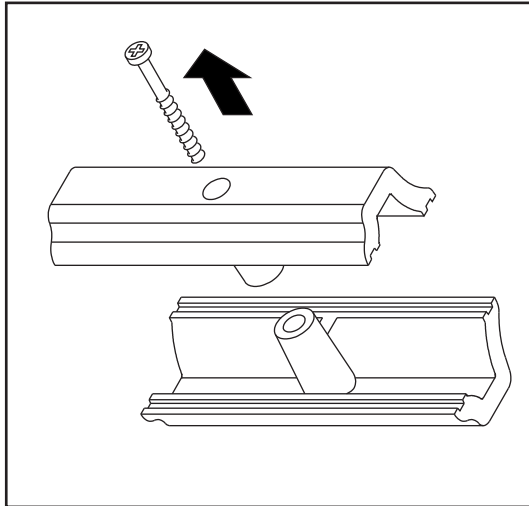

## Separate Lite or Panel Frames

Remove screws or staples to separate lite or panel frames.

## Apply Glazing Tape to Entire Perimeter of Exterior Frame

If not factory applied, apply foam glazing tape (Part No. RPGLZTP).

DO NOT stretch.

Overlap at corners.

Press on lightly with fingers. Then with a roller tool, fully bond gasket using firm pressure.

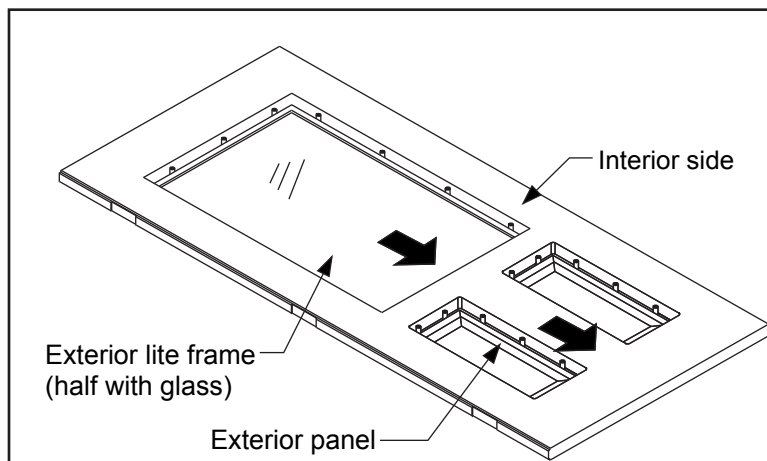
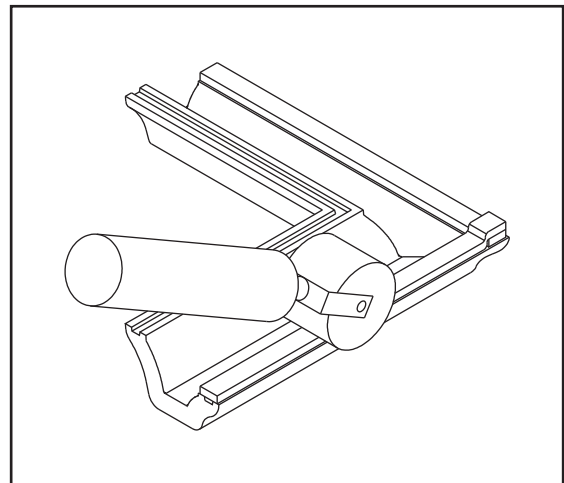

## Position Lite/Panel into Opening

Place lites and panels against bottom edge of cutouts to prevent shifting.

Center lites and panels in cutout, side-to-side

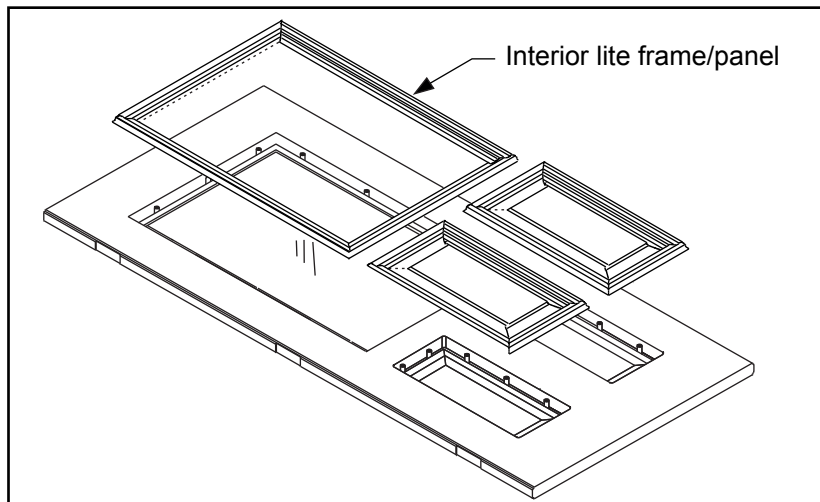

**Position Interior Sides  
of Frames and Panels**

Ensure correct alignment of screw bosses.

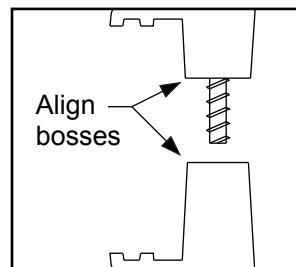

NOTE: When installing multiple lites, use a straight edge to check alignment of lites before securing in place.

**Select the Right Screw**

Use the correct screw with the appropriate lite frame. (Fasteners are shown actual size.)

**For this lite**

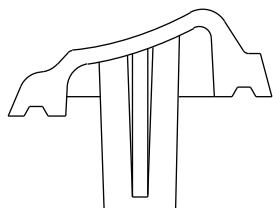

Classic-Craft Doorlite  
(for molded opening)

**Use this fastener**

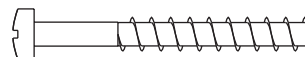

Part # SCDL000

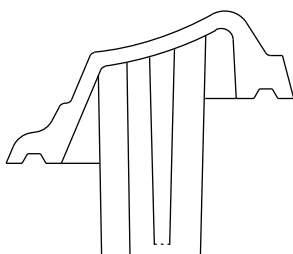

Classic-Craft Doorlite  
(for surface mount)



Part # SCSMCL

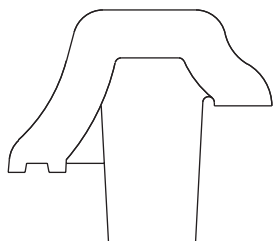

Fiber-Classic Doorlite  
Smooth-Star Doorlite  
Steel Doorlite

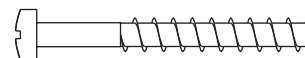

Part # SCDL000

## Select the Right Screw

Use the correct screw with the appropriate lite frame.

Door  
Preparation

### For this lite

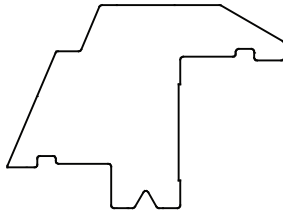

Fiber-Classic Doorlite  
without Screw Bosses  
(no screw plugs)

### Use this fastener

Brass Finish  
Entire Screw

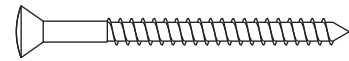

Part # RPSCFCLDL

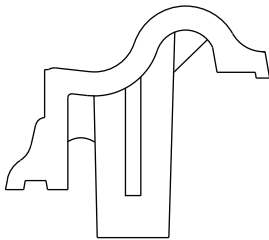

Fiber-Classic, Smooth-Star  
and Steel Doorlites

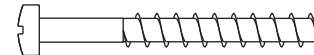

Part # SCDL000

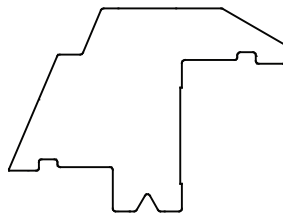

Smooth-Star and  
Steel Doorlites  
without Screw Bosses  
(no screw plugs)

White Painted Head

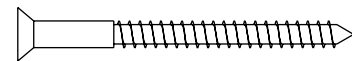

Part # RPSCLDL

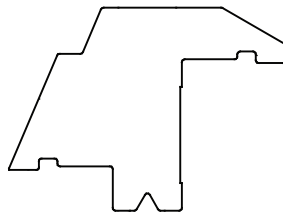

Fiber-Classic, Smooth-Star,  
Flat Frame, and Steel Doorlites  
with Screw Bosses  
and plugs

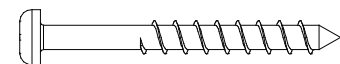

Part # PVCSCREW15

### For this panel

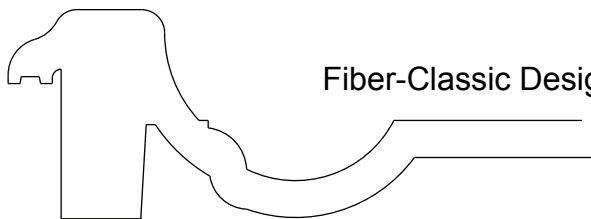

Fiber-Classic Designline Panel

### Use this fastener

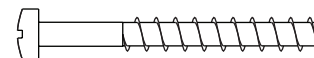

Part # SCDL000



**Select the Right Screw**

Use the correct screw with the appropriate lite frame.

**For this lite**

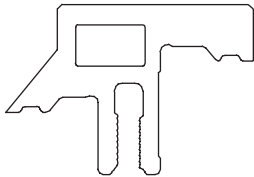

Wrought Iron Doorlite

**Use this fasteners**



Part # CCRSCREW

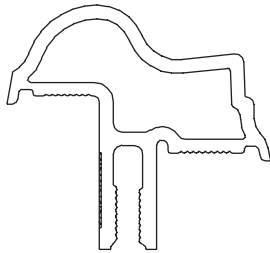

Impact Doorlite



Part # SCCCA150

## Adjust Screwgun Torque

Door  
Preparation



**CAUTION:**  
DO NOT exceed  
maximum torque.

### MAXIMUM AND MINIMUM TORQUE SETTINGS

Doorlite	Torque (in-lbs)
Classic-Craft	9-12
Classic-Craft Wrought Iron & Impact	67-70
Fiber-Classic, Smooth-Star & Steel (with BTS lite frames)	12-14
Fiber-Classic, Smooth-Star & Steel (with PVC lite frames)	7-9

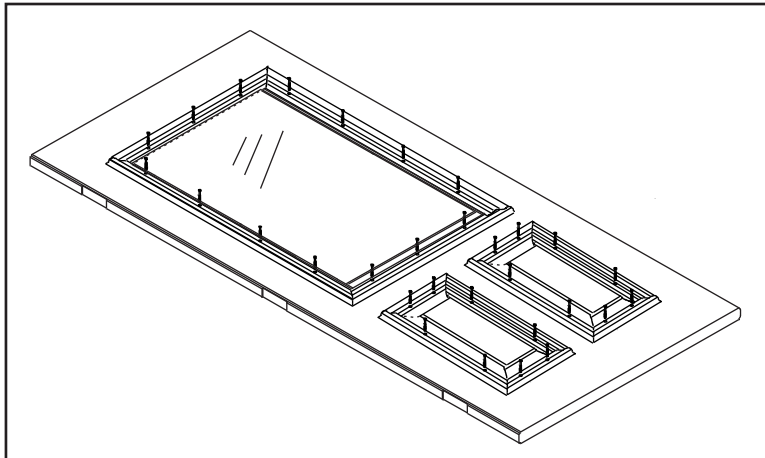

### **Drive Screws with #2 Phillips Bit**

Ensure frame edges are well-seated.

#### NOTE:

Doorlites may be shipped with only enough screws for safe transport. Additional screws may be made up from bulk supply.

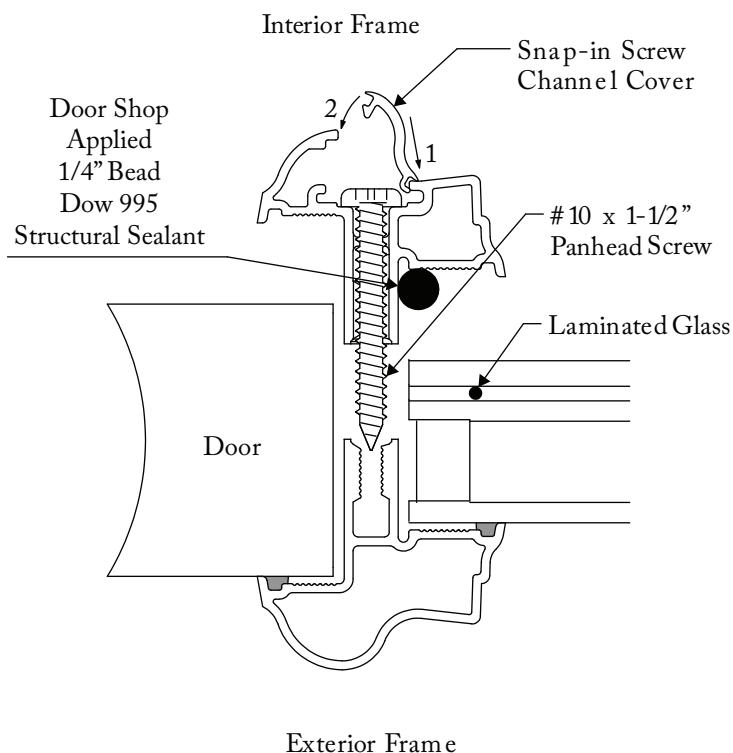

**SCREW CHANNEL COVERS:**

- (1) Place short side of miter to inner edge of frame.
- (2) Rotate cover down snapping long side of miter into place.

NOTE: Fine tuning of lengths may be needed to acquire optimal fit.

The interior frame only must be wet glazed to door slab and insulated glass unit as shown with Dow 995 structural sealant. Minimum 1/4" beads are required.

Assemble with #10 x 1-1/2" pan head screws. Screws to be tightened at 70 in. lbs.

**NOTE:** Laminated glass must be facing the interior frame and the structural sealant.

# Hinge Installation

Door  
Preparation

## Use the Correct Leaf

Leaves applied to door have 2 knuckles.

Leaves applied to jamb have 3 knuckles.

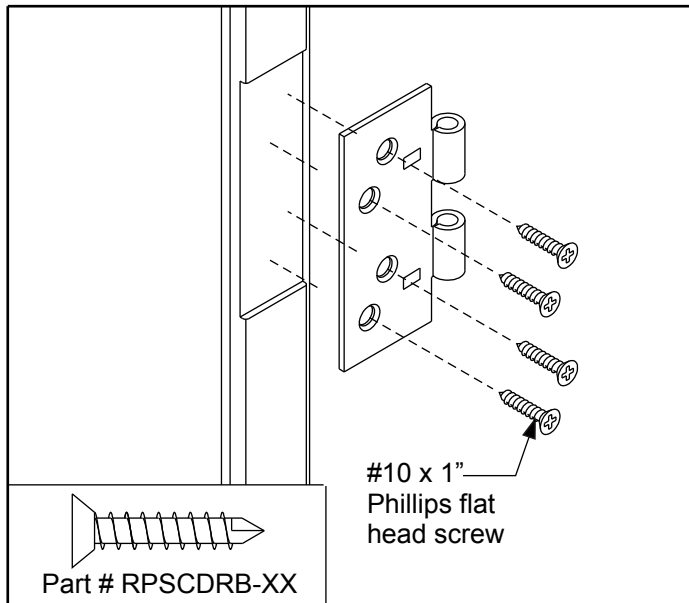
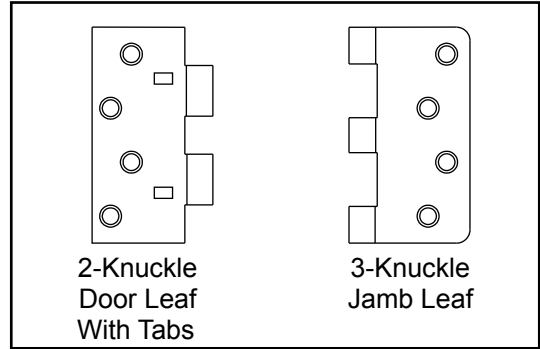

## Pass-Through Mortise

### Align and Install Hinges

Place tabs firmly against door skin.

Fasten 2-knuckle hinge leaves with proper screws.

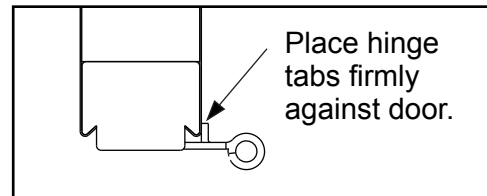

## Full Mortise

### Align and Install Hinges

Use mortises to properly align 2-knuckle hinge leaves.

Drill 1/8" diameter pilot holes if mounting hinges to hardwood stiles.

Fasten 2-knuckle hinge leaves with proper screws.

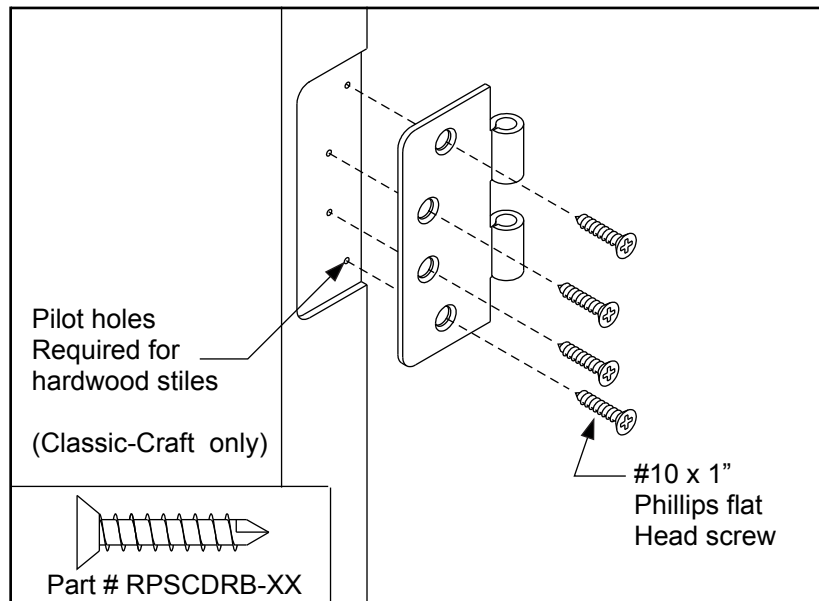

## Adjustable Hinges

### Required Tools

1. A 3/16" hex wrench is required.
2. A small flat head screwdriver is required.
3. A plastic putty knife is recommended to prevent damage to hinge finish.

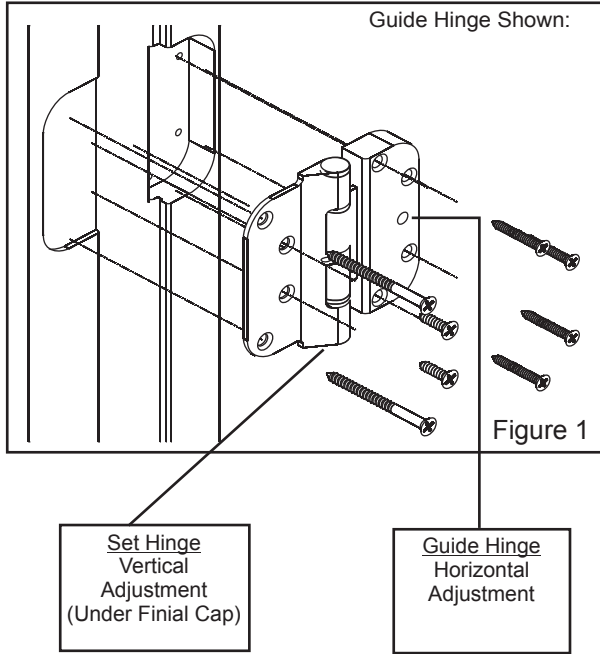

There are two types of Adjustable Hinges on each door panel:

1. **Set Hinge:** one per panel. The set hinge provides  $\pm 0.12$ " vertical adjustment.
2. **Guide Hinge:** Two or three per panel. The guide hinges provide  $\pm 0.12$ " horizontal adjustment. The two Guide Hinges go in top and bottom locations with the Set Hinge in the center. For 8' door the Set Hinge is located second from top of door. Refer to Figure 2.

### Assembly Information

1. Insert the thick side of the hinge into the hinge mortise on the door.
  2. Pre-drill 3/32" diameter pilot holes through hinge holes.
  3. Fasten with (4) #8 x 1-1/4" flat head screws refer to Figure 1.
  4. Place hinges into hinge mortise on the frame.
  5. Seat hinge to back of machined hinge pocket.
  6. Fasten with (2) #10 x 3/4" flat head screws in the middle of each hinge.
- Fasten the top & bottom holes with (2) 2-1/2" flat head screws

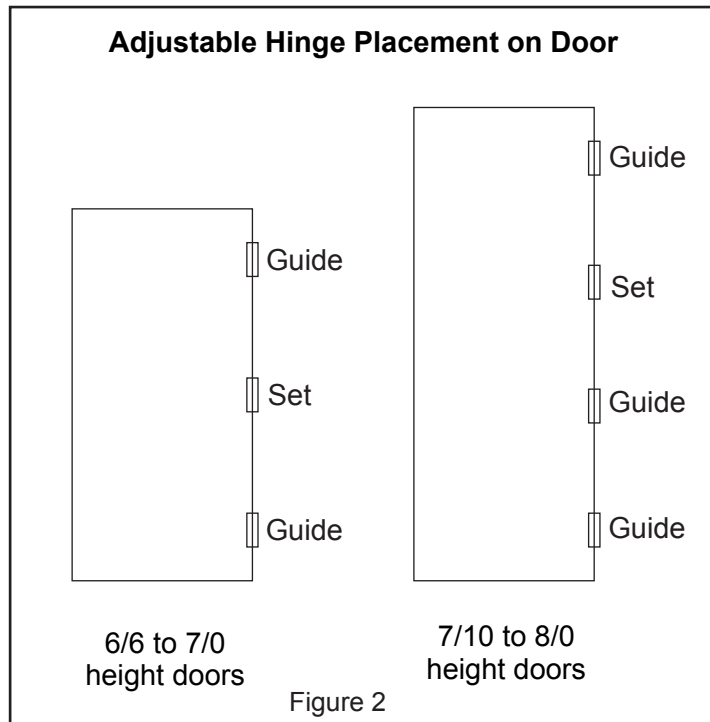

### Vertical Adjustment (Set Hinge)

- With the door closed or open
1. Remove the press-fit Finial Cap from the bottom of the Set Hinge to expose the adjustment screw. Use the small screwdriver for Set Hinges featuring a plastic Finial Cap. A plastic putty knife is recommended for Set Hinges featuring a brass Finial Cap.
  2. Insert the hex wrench into the bottom of the Set Hinge. Turn the screw clockwise to raise the panel and counterclockwise to lower the panel.
  3. Reinstall the Finial Cap.

### Horizontal Adjustment (Guide Hinge)

- The door must be open to access the adjustment screw.
1. Insert a 3/16" hex wrench into the horizontal adjustment screw.
  2. Turn clockwise to decrease the margin and counterclockwise to increase the margin on the hinge side.

# Hinge Installation

Door  
Preparation

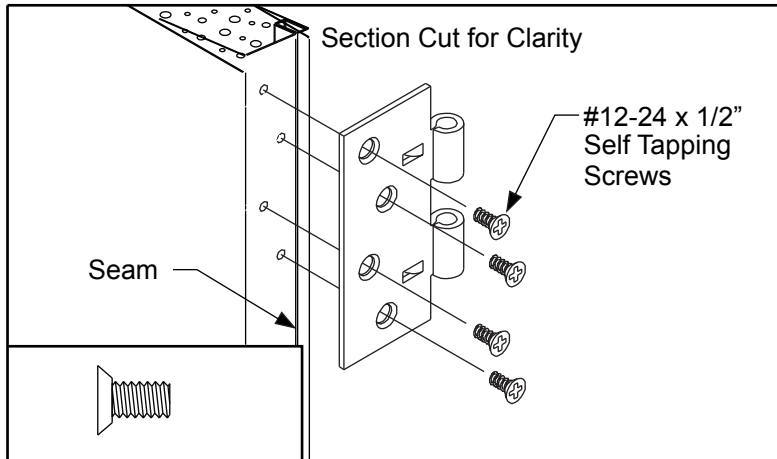

## Surface-Mounted (90-Minute Fire Door)

### Align and Install Hinges

Use pilot holes to align 2-knuckle hinge leaves.

Fasten 2-knuckle hinge leaves with proper screws.

### Considerations for Assembled Hinges

Riveted-pin hinges have locating tabs. Fasten to slabs using same method as for unassembled hinges, placing tabs against door face to locate hinge.

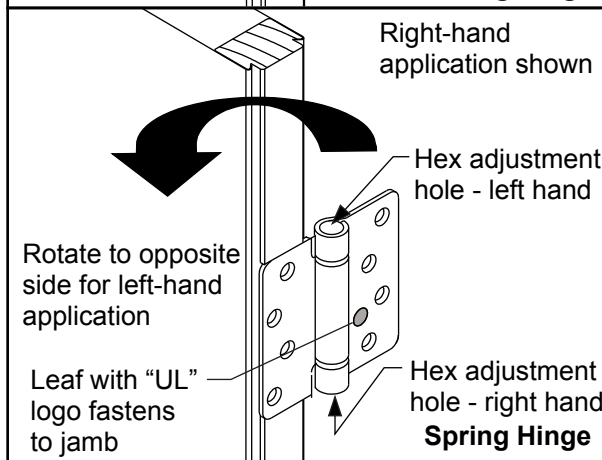
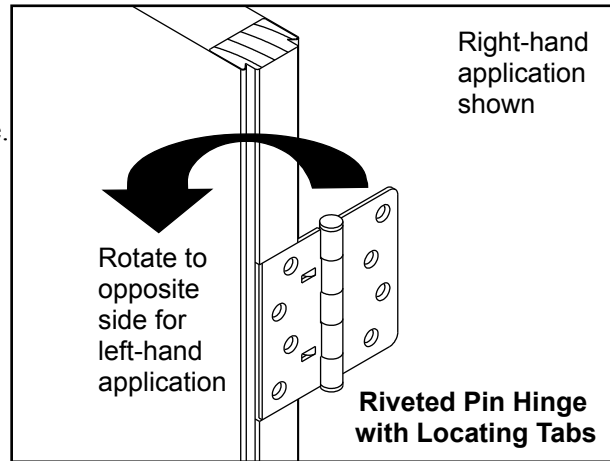
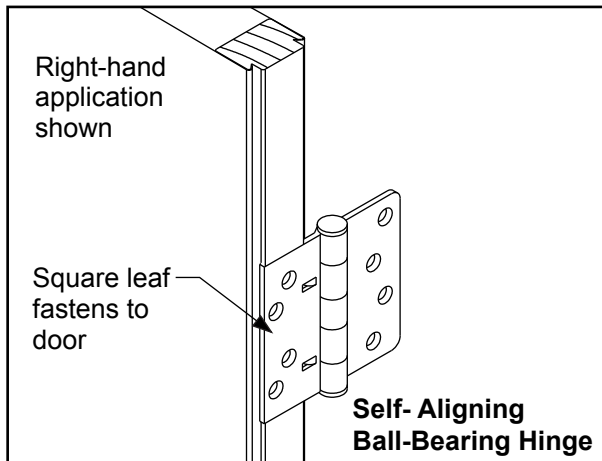

For wood-edged doors with pass-through hinge mortises, take care to place correct leaf on door edge, and fasten at correct backset, for alignment. (Backset is 1-3/8")

To apply these hinges to wood-edged doors, use a template and mark screws or bore 3/32" diameter pilot holes.

A standard hinge leaf with locating tabs can also be used as a template, if a vix-bit is used to center the pilot holes in the centers of the hinge holes.

*If assembled hinges are used, fastening door slabs to frames will require that the slabs be first fastened to loose hinge jambs, with the rest of the frame and sill then being built around the slab.*



**CAUTION:**  
**THIS SECTION**  
**APPLIES ONLY TO:**

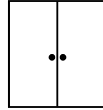

French  
(Wide Patio  
Mullion only)

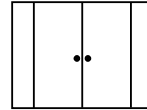

French with  
Two-Sidelite Units  
(Wide Patio  
Mullion only)

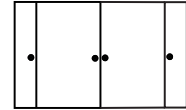

French with  
Two Vented Sidelites  
(Wide Patio  
Mullion only)

Door  
Preparation

## Aluminum Astragal

### Set Astragal on Door

Align astragal to slab which is to be "fixed".

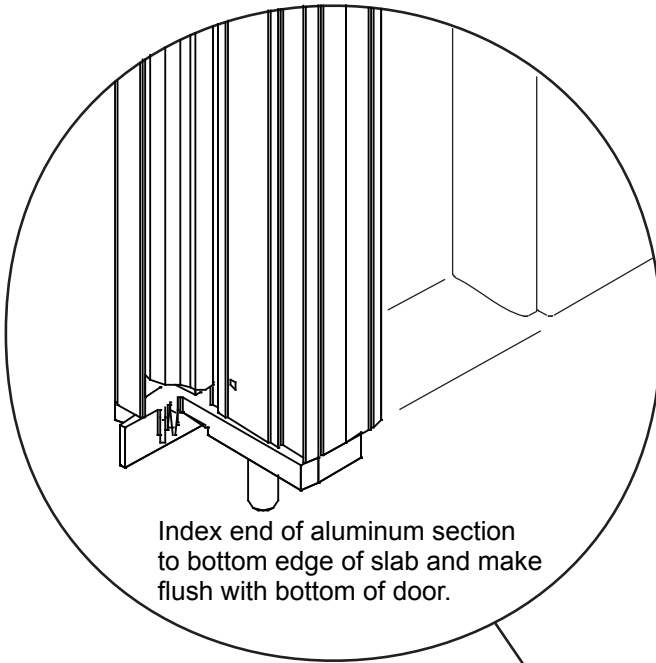

### Drill and Secure Astragal

Drill through mounting holes in astragal into fixed door using 1/8" dia. bit.

\*For astragals with 17" slide bolts:  
Slide the bolts and retainers toward the center of the astragal to expose the mounting holes at each end. Install the two #10 x 1-1/2" end mounting screws first (per diagram). Then replace the retainers flush with the astragal ends and tighten set screws.

Finish securing astragal to door lock edge through pre-punched mounting holes with three additional (Six for 8/0 astragals) provided #10 x 1 1/2" pan head screws. (Note: upper and lower mounting screws also secure bolt spring clip.)

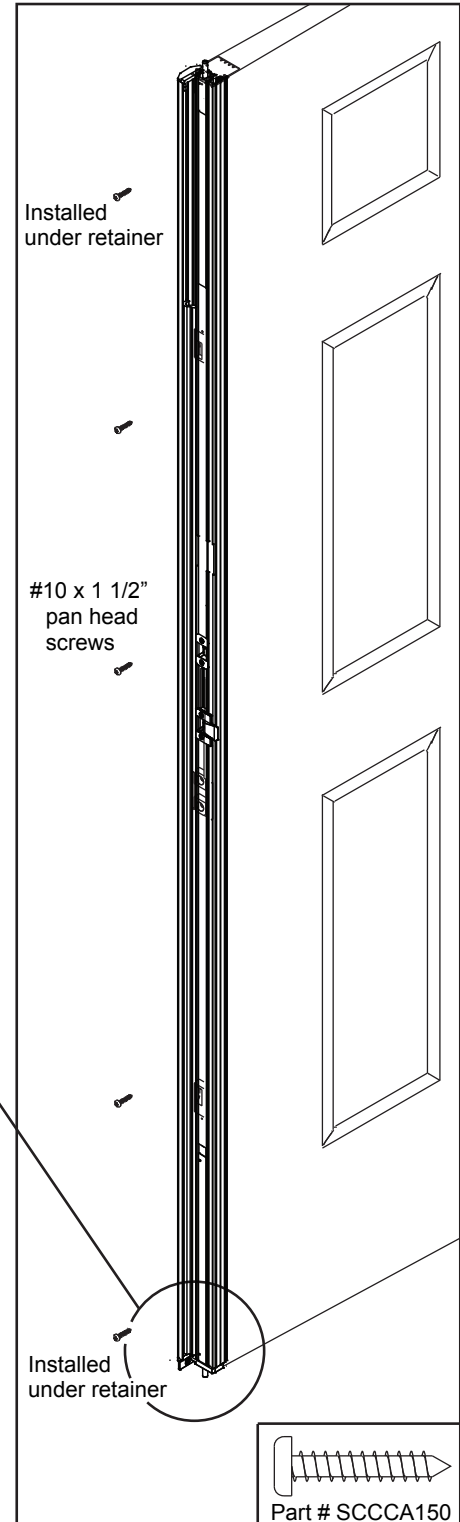
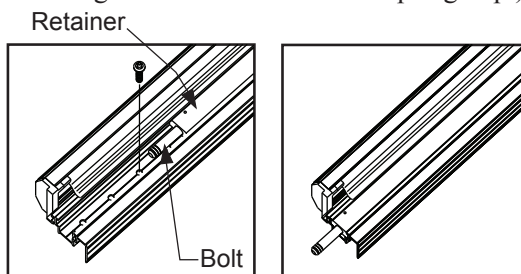

# Astragal Installation

Door  
Preparation

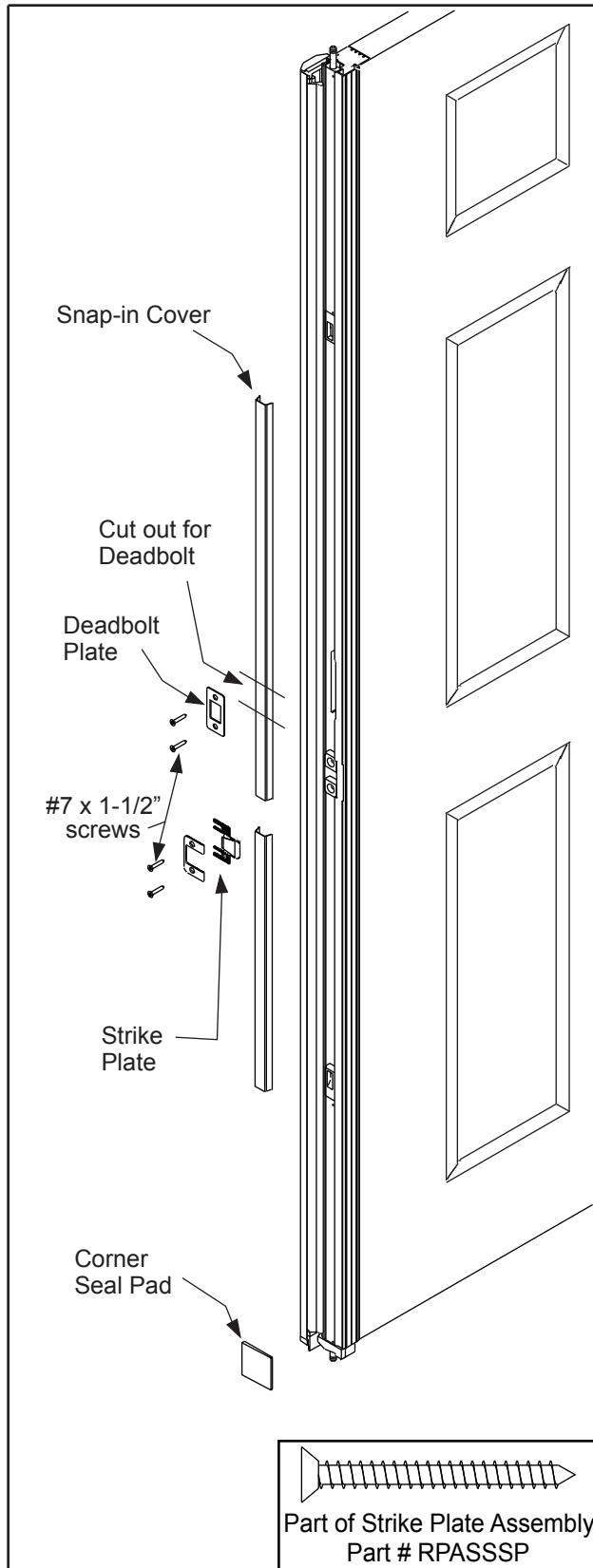

## Aluminum Astragal

### Fasten Strike Plate Assembly

Position strike mount at latch centerline.

Tape strike mounts temporarily in place thru strike slot.

### Fasten Strike Plates

Fasten strike plate with (2) #7 x 1-1/2" screws Provided.

If deadbolt is used, mark the deadbolt centerline and position deadbolt plate on the astragal.

Holding the deadbolt plate in place, pre-drill 2 mounting holes using a 3/32" drills.

Fasten the deadbolt plate with (2) #7 x 1-1/2" screws provided.

### Apply Snap-in Cover

If deadbolt is used, mark centerline of bolt and cut long snap-in cover to allow bolt to engage in aluminum extrusion.

Place longer snap-in cover with top of strike plate and snap into place.

Align shorter snap-in cover with bottom of strike plate and snap into place.

### Apply Corner Seal Pad



**CAUTION:**

Corner seal pads are only used with inswing units.

Apply corner seal pad against weatherstrip with bottom edge in line with bottom edge of seal.

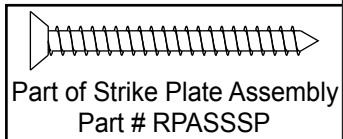



## Coastal Astragal

### Set Astragal on Door

Align astragal to slab which is to be "fixed".

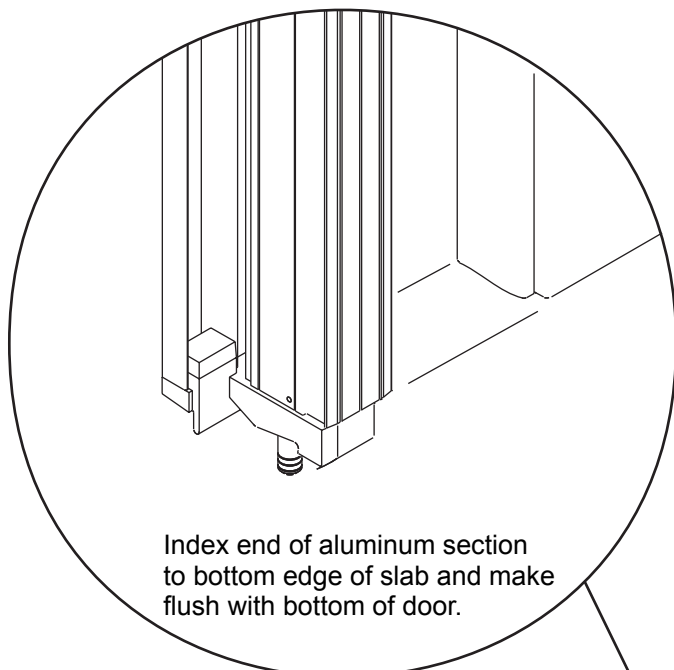

### Drill and Secure Astragal

Drill through mounting holes in astragal into fixed door using 1/8" dia. bit.

Secure astragal to door lock edge through pre-punched mounting holes with provided #10 x 1-1/2" pan head screws.

### Apply Snap-In Cover

Align longer snap-in cover with the top of strike plate and snap into place.

Align shorter snap-in cover with bottom of strike plate and snap into place.

### Apply Corner Seal Pad

Apply corner seal pad against weatherstrip with bottom edge in line with bottom edge of seal. Repeat at top edge in line with edge of top seal.



**CAUTION:**  
Corner seal pads are only used with inswing units.

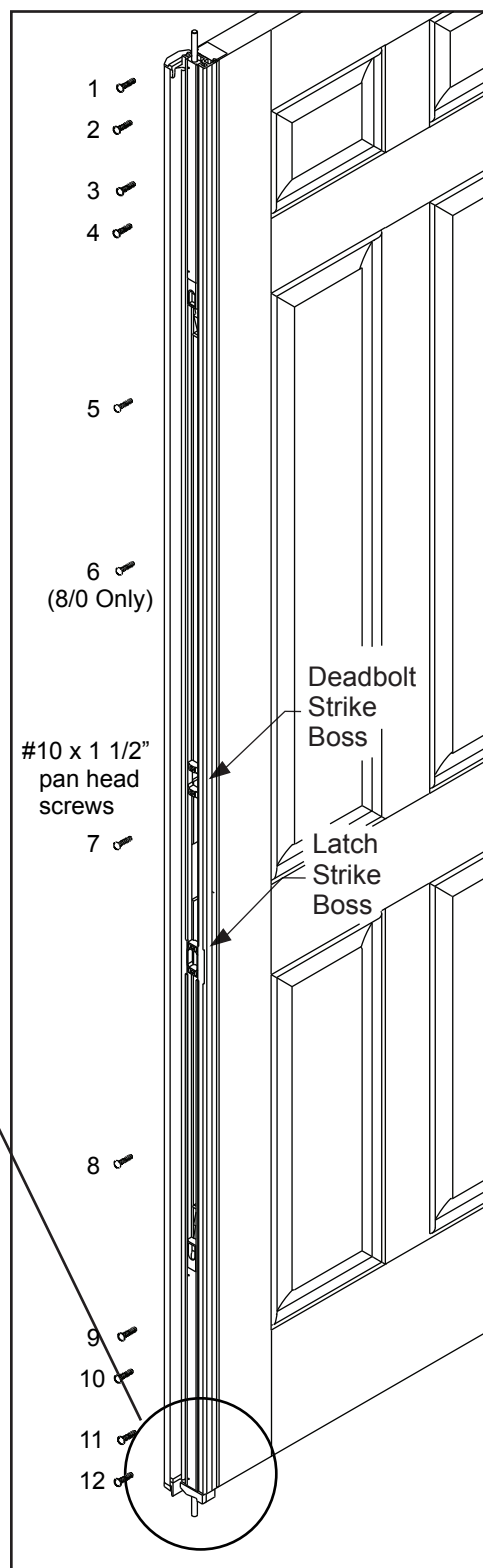

## Select Door Bottom

Door  
Preparation

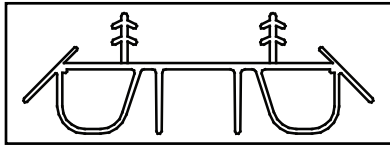

**Dual Bulbed Kerf-Applied  
Door Bottom DBDB300**

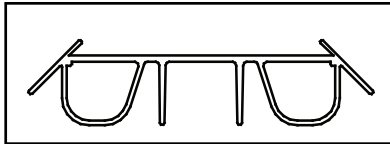

**No Kerf  
Door Bottom RPDBDB300T**

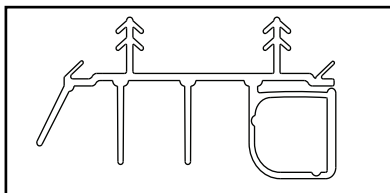

**Kerf-Applied  
Door Bottom DB30094**

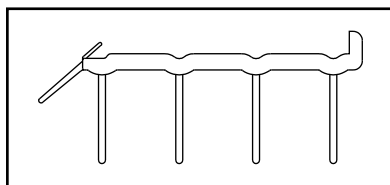

**Sweep/Replacement  
Door Bottom DB30SWP**

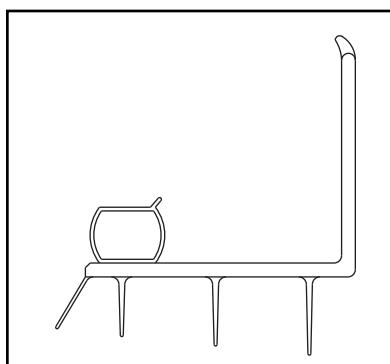

**Fire Door Bottom TSA30**

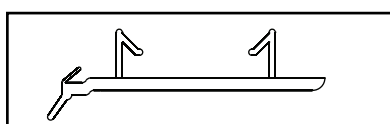

**Outswing Kerf-Applied  
Door Bottom DB30OS99**

## Compatible sill types:

Any Composite Adjustable, Hardwood Adjustable, or Basic Composite Adjustable Inswing Sills.

Any Composite Adjustable, Hardwood Adjustable, or Basic Composite Adjustable Inswing Sills.

Basic Fixed Sill  
Moderate Climate Sill

Any sill  
Public Access Sill

Primarily used as a replacement door bottom

Used on cutdown doors when kerfs are trimmed away.

Public Access Sill

(Recommended)  
Outswing Sills with exception of Composite Fixed



**CAUTION:**  
Outswing units with bumper sills do not require door bottoms.

**Kerf Door Bottoms**

***Caulk and Fasten Door Bottom***

Select a sealant (Elastomeric or Polyurethane) that provides excellent adhesion to both plastic and wood.

**Apply sealant as shown to both ends of door bottom.**

Center door bottom and press into rail kerfs.

Fasten ends of door bottom with (2) 1/4" or 1/2" crown x 3/4" or 7/8" staple on each end.

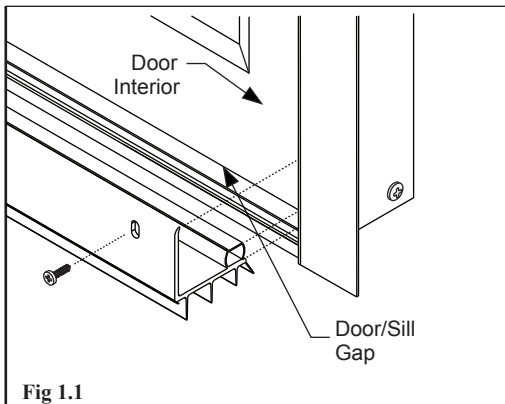
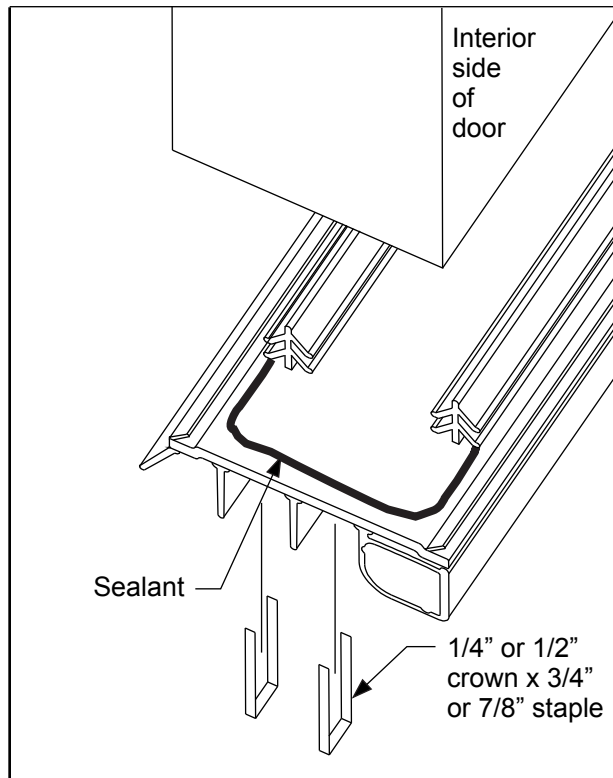
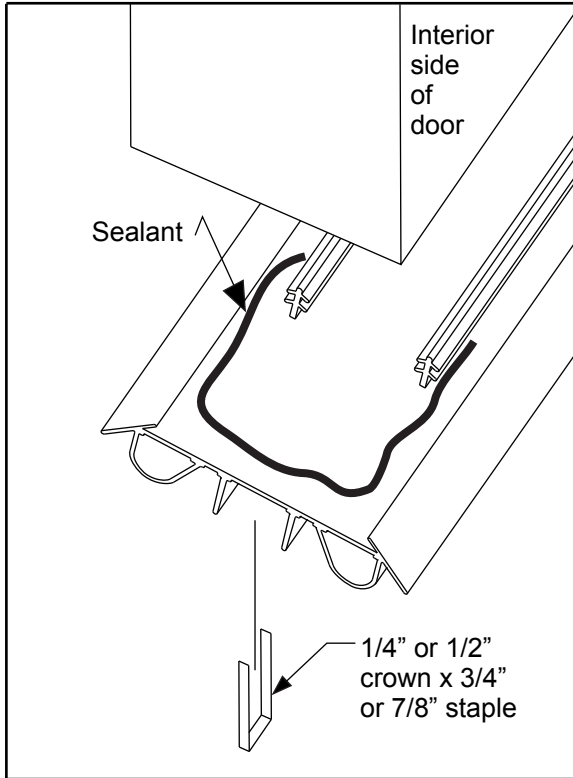

**'90-Minute Fire Door' Door Bottom**

***Fasten Door Bottom***

Slide door bottom between door and sill. Align at ends and against inside face with lip. Screw door bottom in place with (5) # 8 x 1/2" self piercing spear tip screws beginning in the center and working out to ends.

# Door Bottom Selection & Installation

Door  
Preparation

## Sweep/Replacement Door Bottom

### **Fill Kerfs with Sealant**

Fill kerfs in bottom rail with sealant (Elastomeric or Polyurethane) if working with trimmed door and shallow kerfs.

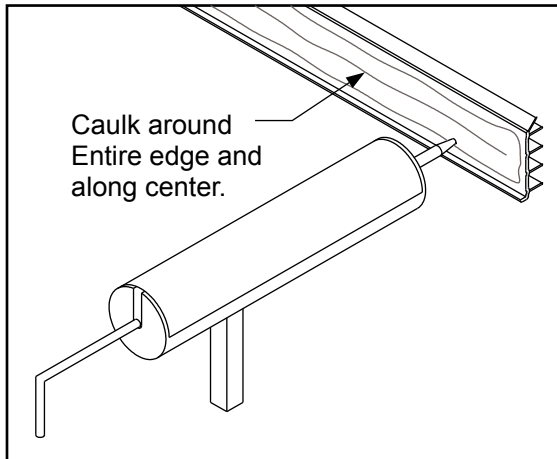
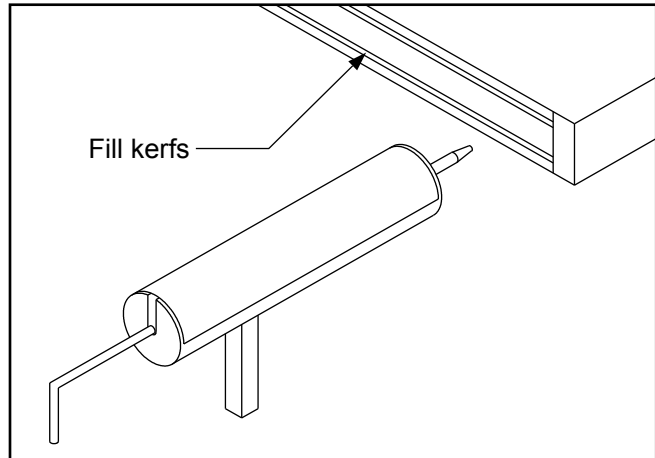

### **Caulk Sweep/Replacement Door Bottom**

Select a sealant (Elastomeric or Polyurethane) that provides excellent adhesion to both plastic and wood.

Apply bead of sealant (Elastomeric or Polyurethane) to entire edge and center of the door.

### **Fasten Door Bottom**

Place door bottom against rail.

Align at ends and against inside face with lip.

Staple in place, beginning at center.

Work toward each end and fasten as shown. Press flat to avoid scalloping.

Staple twice at each end as shown.

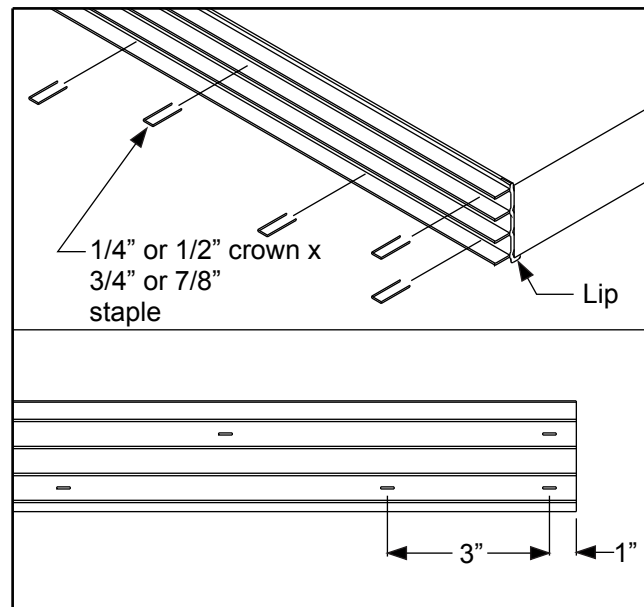

NOTE: Wood Grilles are for internal use only.

Grilles come complete with clips.

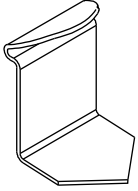
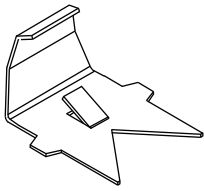
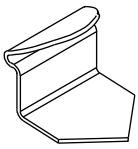
BTS	FLUSH GLAZED	CC
		
Part # RPWGMC2	Part # RPFGGC	Part # RPCGC

**SPRING STEEL CLIPS**

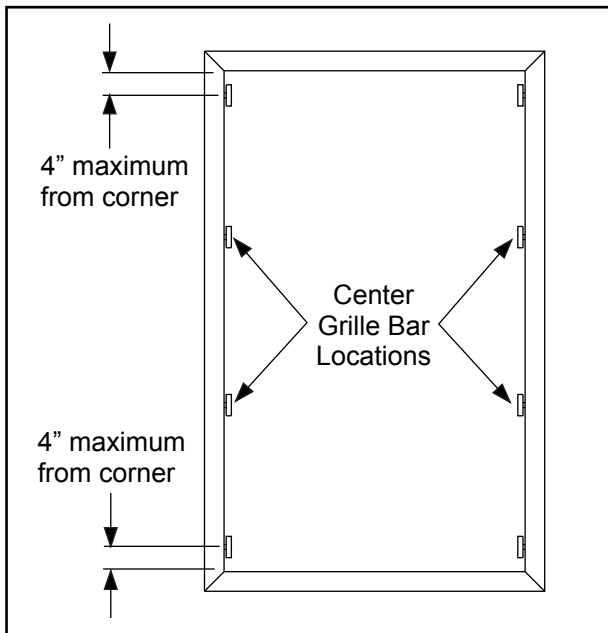

**Position Clips**

Locate clips on vertical sides of frames  
4" maximum from each corner and at  
center grille bar locations.

**Installation for Lite Frames**

**Install Clips**

Loosen doorlite screws slightly.

Slide flat side of clips under  
interior side of doorlite frame.

Retighten screws.

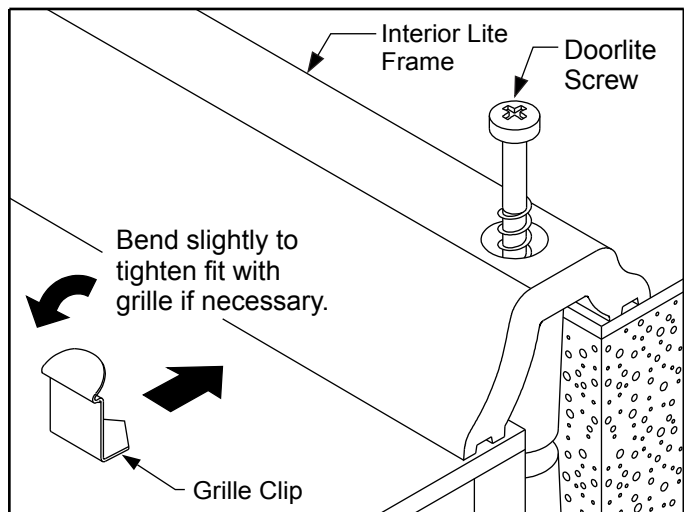

# Grille Installation

Door  
Preparation

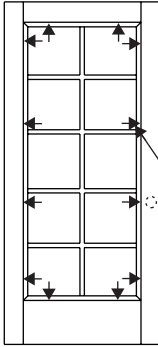

## Installation for Flush-Glazed Doors

To assure proper installation, carefully remove any excess sealant at glass edge before installing grille clips.

Insert steel spring clips between stop and glass at the locations shown. **AVOID PUTTING CLIPS IN LINE WITH MUNTINS HORIZONTAL AND VERTICAL GRILLE BARS.** (Note: number of clips may vary from shown due to grille size and door style.)

Use the installation tool as shown to push the clip completely into the locked position.

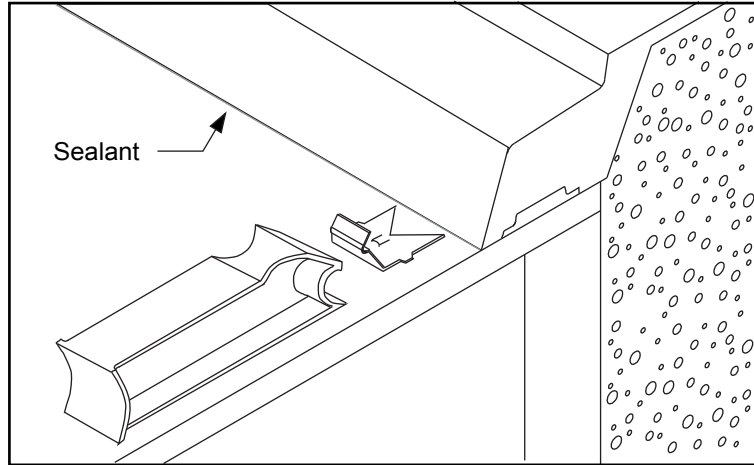

Section Cut for Clarity

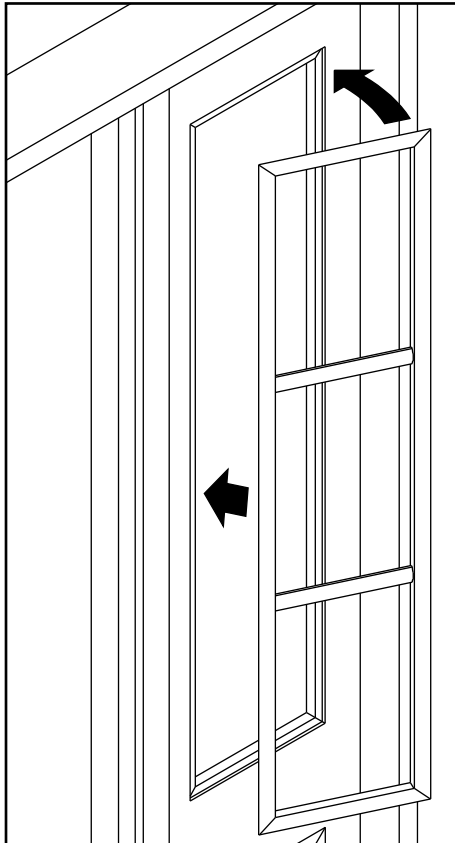

With all the clips installed, insert grille against clips on one side. Gently push opposite side of grille against glass, locking all clips into frame. Remember to gently press the top and bottom of the grille against the glass.

Clips will be hidden when grille is inserted.

To remove, gently pull away from the glass surface at one long side of the grille where the muntins meet the grille frame.

**Installation for Flush-Glazed  
Classic-Craft®**

Locate grille clips under molding edges where molding meets glass.

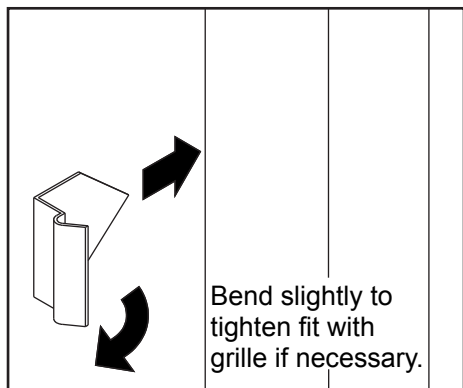
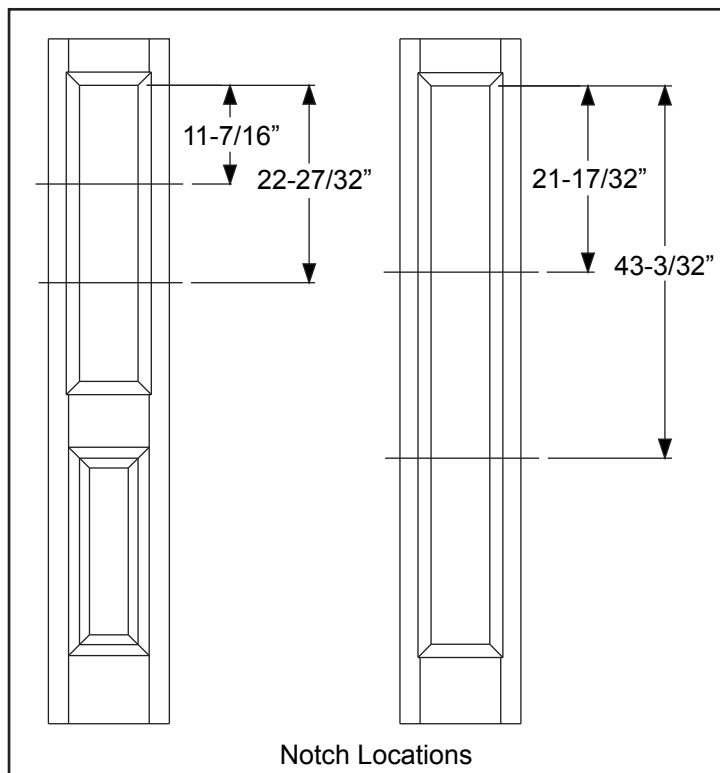

Insert grille clips by sliding in spade edge of clip under molding and press clip all the way in.

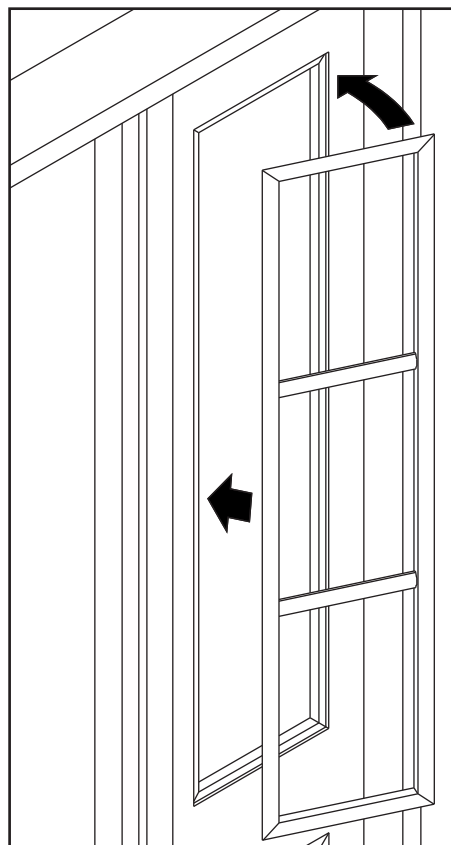

Insert grille into door, placing one long side against hardware.

Snap into place along all other sides.

**NOTE: TEMPERATURE RANGE FOR OPTIMUM TAPE ADHESION IS 70 TO 100 F. MINIMUM SUGGESTED APPLICATION TEMPERATURE IS 60 F. THE DOOR AND LITE DIVIDER ARE TO BE IN THIS TEMPERATURE RANGE. ALLOW 72 HOURS FOLLOWING APPLICATION FOR FULL BOND STRENGTH ON TAPE.**

1. Remove black tape from both sides of the slab as indicated on the glass label.
2. Moisten a clean cloth with 70% Isopropyl Alcohol. Wipe both sides of glass as shown at right.



**NOT PREPARING THE GLASS WILL RESULT IN POOR TAPE ADHESION.**

3. Lay out dividers in desired pattern in the lite opening. For the 4- and 6-lite packs: the long dividers are placed vertically, the short dividers are placed horizontally.
4. Position template in lower left corner of lite opening (see page 2), with the top of the template (as marked) toward the top of the door.
5. Working with vertical dividers first, remove carrier backing from the divider. **NOTE: ADHESIVE IS NOT REPOSITIONABLE.**
6. Position divider, adhesive side toward the glass, using the template as a guide for placement.
7. Press firmly to the glass to secure adhesive. Note: allow 72 hours following application for full bond strength of adhesive.
8. Apply remaining dividers (repositioning the template where applicable) in the same manner.
9. Repeat the same installation steps for the other side of the door.

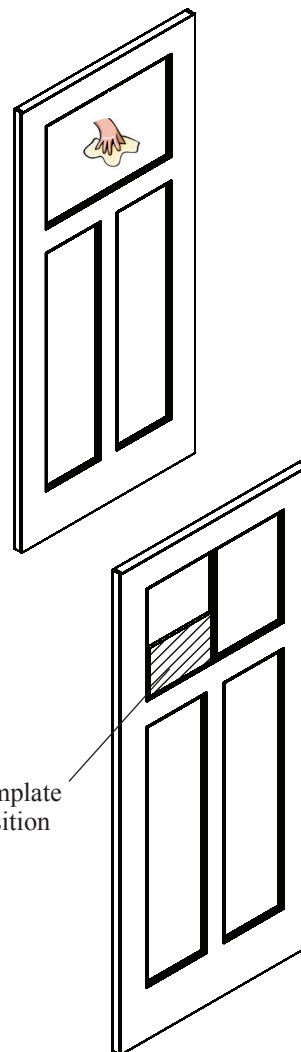

**EXAMPLE**

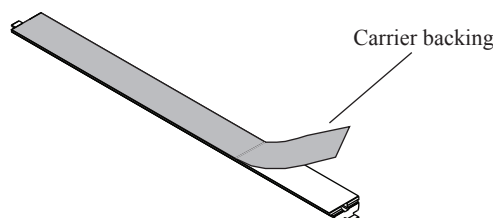

Recommendations:

Apply all vertical dividers BEFORE applying horizontal dividers.  
Use a veneer roller over fully-positioned lite dividers to increase adhesion.



Template Part Number:  
TPA2618LD2-P for 26 x 18  
TPA3024LD2-P for 30 x 24

Template Part Number:  
TPA2618LD3-P for 26 x 18  
TPA3024LD3-P for 30 x 24

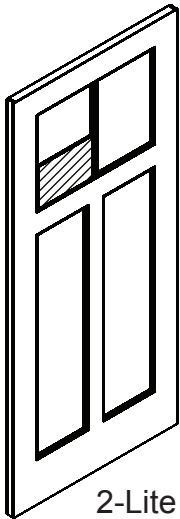

2-Lite  
Template  
Position

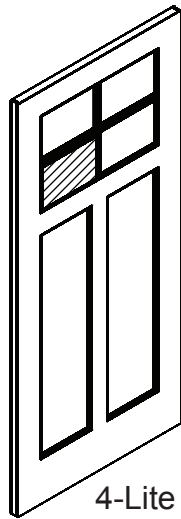

4-Lite  
Template  
Position

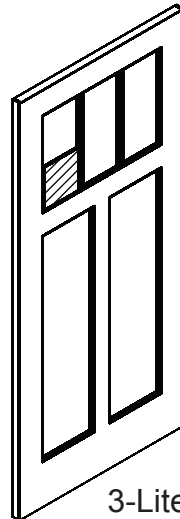

3-Lite  
Template  
Position

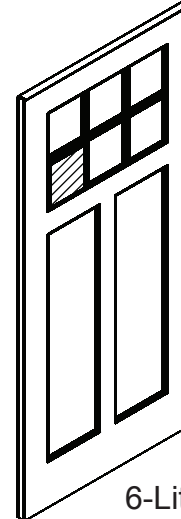

6-Lite  
Template  
Position

Template Part Number:  
TPA0866LDSL5-P



5-Lite  
6'8" Sidelite  
Template Position

Template Part Number:  
TPA0818LDSL2-P

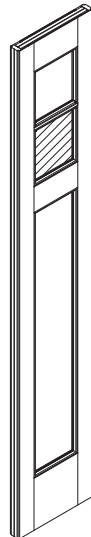

2-Lite  
6'8" Craftsman  
Sidelite  
Template Position

Template Part Number:  
TPA0880LDSL6-P



6-Lite  
8'0" Sidelite  
Template Position

# SDL Bar Installation Instructions (Smooth Star / Fiber Classic)

**NOTE: TEMPERATURE RANGE FOR OPTIMUM TAPE ADHESION IS 70° TO 100°F. MINIMUM APPLICATION TEMPERATURE IS 60°F. BOTH THE DOOR AND LITE DIVIDER ARE TO BE IN THIS TEMPERATURE RANGE. ADHESIVE IS NOT REPOSITIONABLE.**

## Materials Needed:

70% Isopropyl Alcohol or adhesion promoting solution  
Clean rags  
½" Masking tape  
J-Roller  
Shim stock or business card  
Pencil  
Plastic zip ties or coffee stirrers  
Sanding materials

**When installing over GBG's only use bronze flat bar patterns**

**When installing on flush-glazed slabs, remove black tape as indicated on the glass label.**

## SDL Preparation for Interlocking Bar Patterns:

1. Starting at the external glass side, take a horizontal divider and place it at the top of the glass. Center the bar in the opening and use the notch(es) on the divider to mark on the frame the top position of the vertical divider(s). Slide the bar to the bottom of the glass and repeat for the bottom position of the vertical dividers.
2. Take a vertical divider and center between the frame markings. Mark amount of bar to trim (if necessary). There should be 0.015" - 0.020" clearance (use a business card as a shim) on each side to allow for expansion or contraction. Repeat for each vertical divider. Be sure to mark each divider with its location (left/right).
3. Trim bars at appropriate angle (see below) to their correct size. Trimming may be done with a stationary belt sander, disc sander, or sanding block.

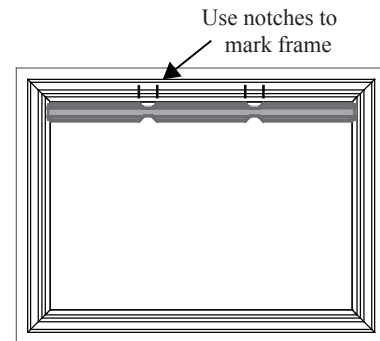

Framed Lites  
(7x64, 21x15, 22x47, 22x64)

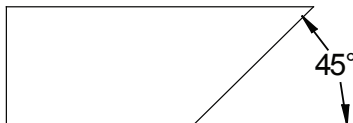

Framed Lites  
(8x36, 8x47, 20x64, 22x36)

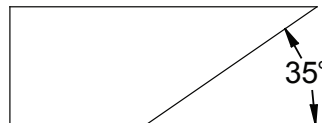

Flush Glazed  
(all sizes)



4. Place a trimmed vertical bar to one side of the glass and use the notches on the dividers to mark on the frame the position of the horizontal dividers. Repeat on the other side of the glass.
5. Assemble the vertical and horizontal bars together and center the bars on the glass at the frame markings without removing the carrier backing tape. Mark amount of bar to trim (if necessary). There should be 0.015" - 0.020" clearance on each side. Repeat for each horizontal divider. Be sure to mark each divider with its location (top, bottom, center, etc).
6. Disassemble bars. Trim bars at appropriate angle to their correct size.

- Assemble the horizontal and vertical divider(s). Use masking tape to secure the divider bars together at the joints. Peel off the Carrier Backing from all of the divider pieces. Clean any trimming residue from tape using 70% Isopropyl Alcohol. Lightly place the tips of small zip ties or coffee stirrers roughly 1/8" onto the adhesive backs as shown. For each of the divider bars, position 1 tie at each end of the divider and each joint, and 1-2 ties in the middle. The ties will keep the adhesive backing off of the glass during final positioning.

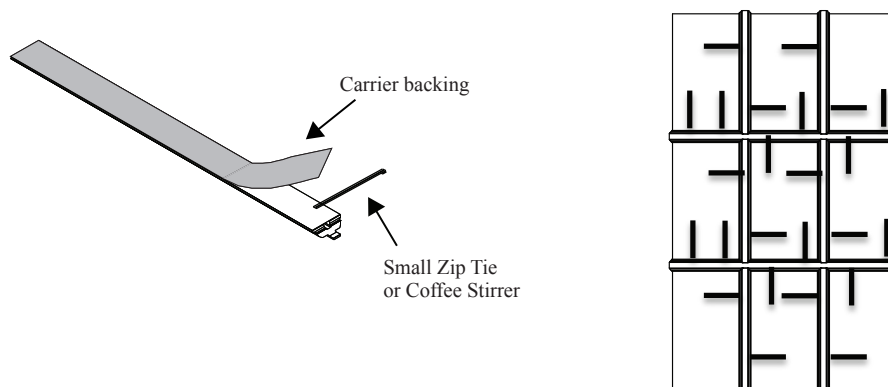

#### Glass Preparation:

Moisten a clean cloth with 70% Isopropyl Alcohol or use an adhesion promoting solution. Wipe the glass before attaching dividers. Allow to dry.

**FAILURE TO PREPARE THE GLASS PROPERLY WILL RESULT IN POOR TAPE ADHESION.  
DO NOT USE A GLASS CLEANER TO PERPARE THE GLASS AS THIS WILL PREVENT PROPER ADHESION.**

#### SDL Installation:

- Position the divider grid back onto the glass using the frame position marks. Check to ensure that, for all of the frame to divider points, there is a 0.015" - 0.020" gap between the divider and the frame. Once in position, press down at all of the ends opposite the zip tie to lock the position, and then pull out that zip tie. Once all of the divider ends are attached, pull out the middle zip ties from the dividers. Using a J-Roller, roll firmly along the entire length of the horizontal and vertical dividers. Look through the interior side to confirm all dividers adhere to the glass, particularly around the perimeter and divider joints. Once attached, remove the masking tape.
- Repeat steps for interior frame side.

## SDL Preparation for Non-Interlocking Bar Patterns:

1. Make template to the dimensions required for your lite pattern (see subsequent pages).
2. Beginning with the exterior, position each divider using the proper template and mark position on the frame. Center bar in opening. Mark amount of bar to be trimmed (if necessary). There should be 0.015" - 0.020" clearance (use a business card as a shim) on each side to allow for expansion or contraction. Repeat for each divider. Be sure to mark each divider with its location (top, middle, bottom, etc).
3. Trim bars at appropriate angle (see below) to their correct size. Trimming may be done with a stationary belt sander, disc sander, or sanding block.

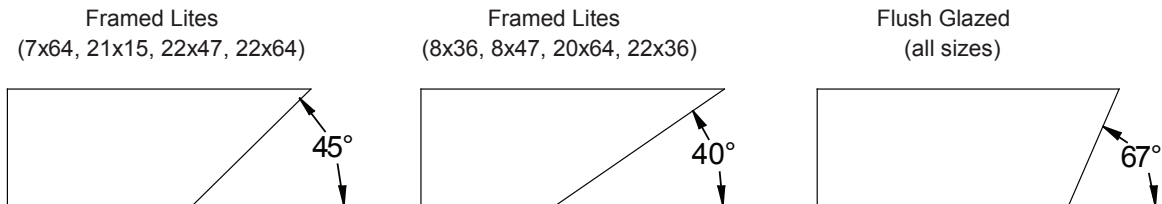

## **Glass Preparation:**

Moisten a clean cloth with 70% Isopropyl Alcohol or use an adhesion promoting solution. Wipe the glass before attaching dividers. Allow to dry.

**FAILURE TO PREPARE THE GLASS PROPERLY WILL RESULT IN POOR TAPE ADHESION.  
DO NOT USE A GLASS CLEANER TO PERPARE THE GLASS AS THIS WILL PREVENT PROPER ADHESION.**

## **SDL Installation:**

1. Peel off the Carrier Backing from all of the divider pieces. Clean any trimming residue from tape using 70% Isopropyl Alcohol. Lightly place the tips of small zip ties or coffee stirrers roughly 1/8" onto the adhesive backs as shown. For each of the divider bars, position 1 tie at each end of the divider and 1-2 ties in the middle. The ties will keep the adhesive backing off of the glass during final positioning.

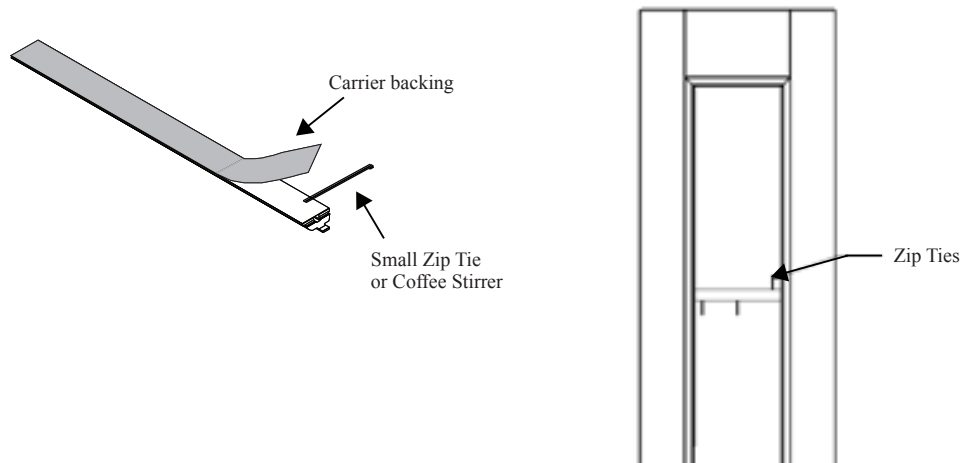

2. Position the dividers back onto the glass using the frame marks. Check that the dividers cover the internal GBGs (if present). Press down on each end of the divider to lock the position and remove the zip tie. Repeat for the other end. Remove the remaining zip tie(s). Using a J-Roller, roll firmly along the entire length of the dividers. Look through the interior side to confirm all dividers adhere to the glass, particularly around the perimeter.
3. Repeat steps for the interior dividers. Check the alignment of the interior dividers with the exterior dividers before attaching interior dividers.

Craftsman Lite 2 Panel  
2W1H

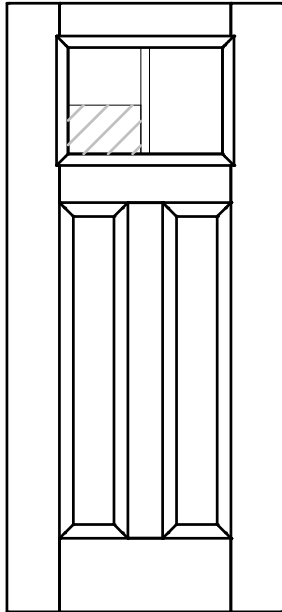

Craftsman Lite 2 Panel  
2W2H

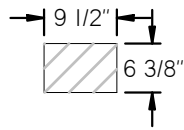
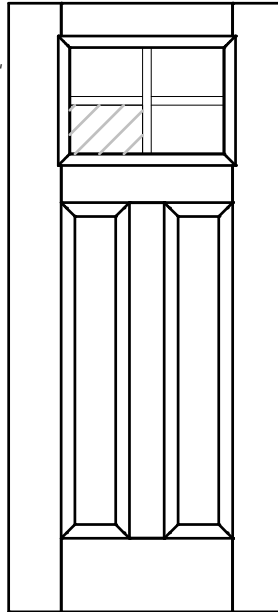

Craftsman Lite 2 Panel  
3W1H

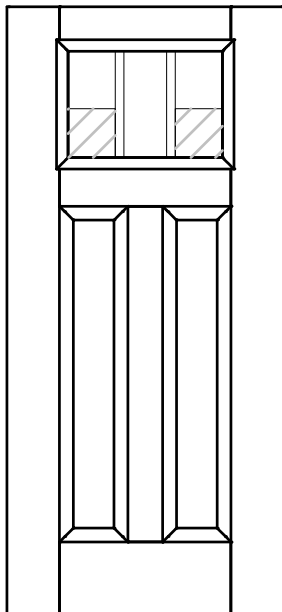

Craftsman Lite 2 Panel  
3W2H

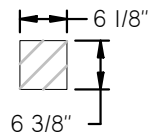
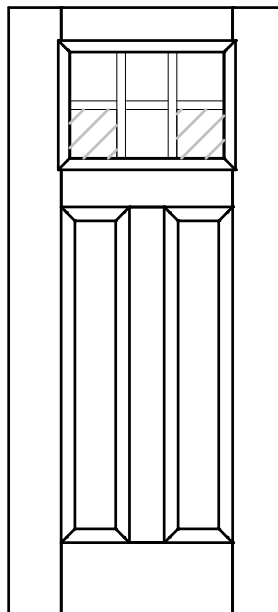

# SDL Bar Installation Instructions (Smooth Star / Fiber Classic)

Door  
Preparation

Full Lite Sidelite  
Flush-Glazed 08x64 IW5H

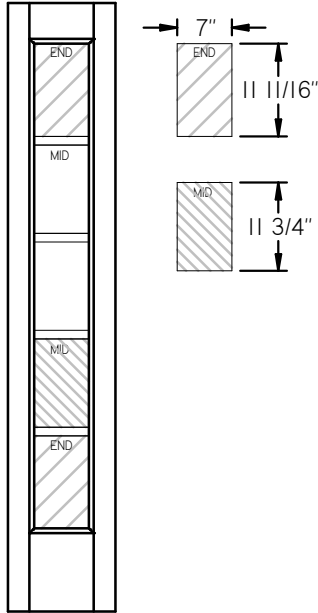

Full Lite Sidelite  
Flush-Glazed 07x64 IW5H

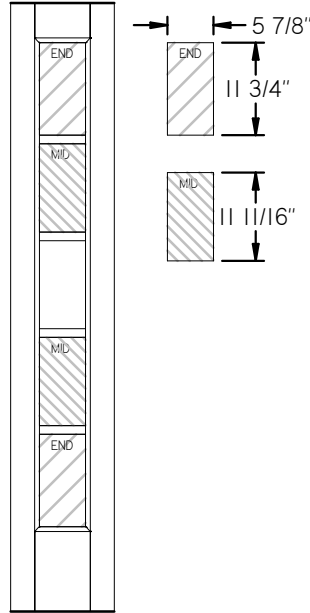

Full Lite Sidelite  
Framed 07x64 IW5H

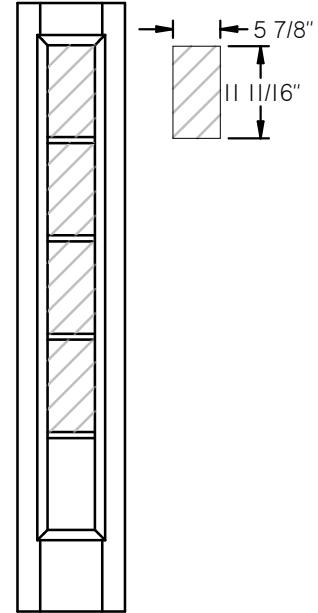

Full Lite Sidelite Flush-Glazed  
08x64 1 Lite Craftsman

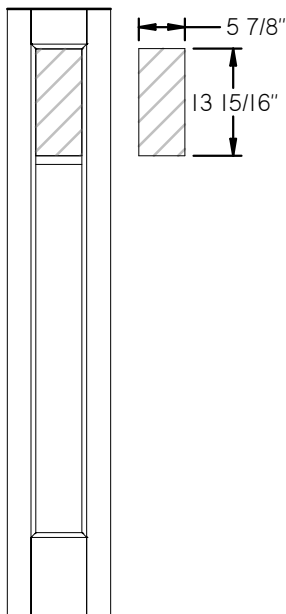

3/4 Lite Sidelite  
Framed 08x47 IW4H

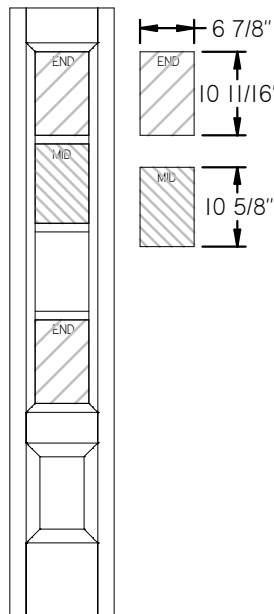

Half Lite Sidelite  
Flush-Glazed 08x36 IW3H

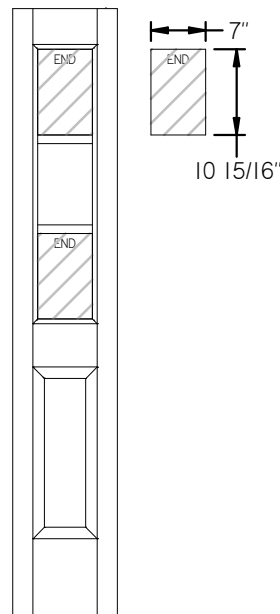

Half Lite Sidelite  
Framed 08x36 IW3H

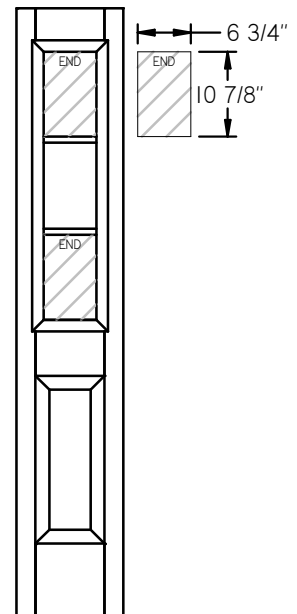

Craftsman Lite 2 Panel Shaker  
Flush-Glazed 2WIH

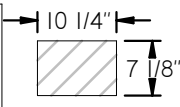
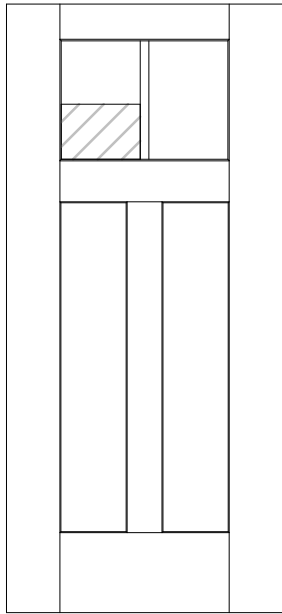

Craftsman Lite 2 Panel Shaker  
Flush-Glazed 2W2H

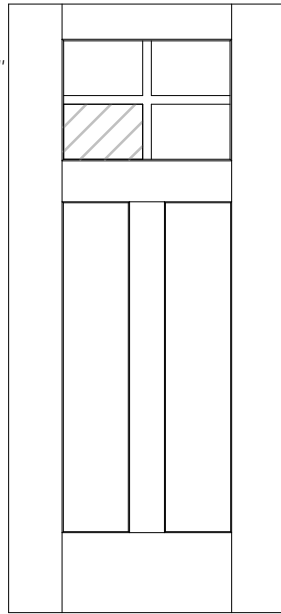

Craftsman Shaker Sidelite  
Flush-Glazed 1W2H

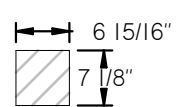
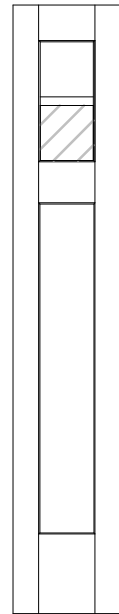

Craftsman Lite 2 Panel Shaker  
Flush-Glazed 3WIH

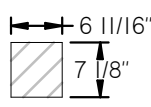
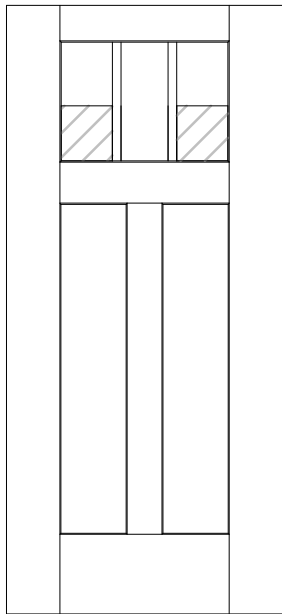

Craftsman Lite 2 Panel Shaker  
Flush-Glazed 3W2H

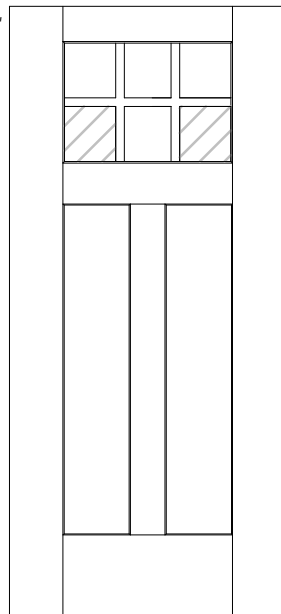

# SDL Bar Installation Instructions (Smooth Star / Fiber Classic)

Door  
Preparation

8' Craftsman Lite2 Panel Shaker  
Flush-Glazed 2WIH

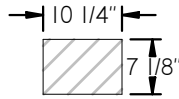
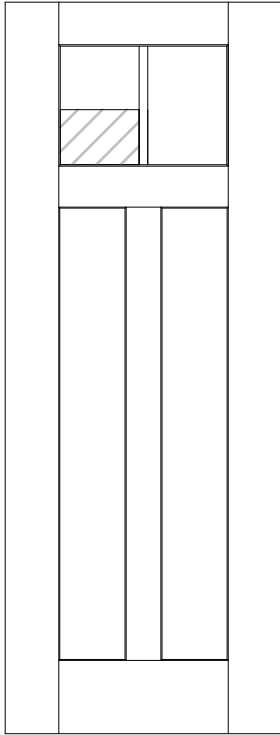

8' Craftsman Lite2 Panel Shaker  
Flush-Glazed 2W2H

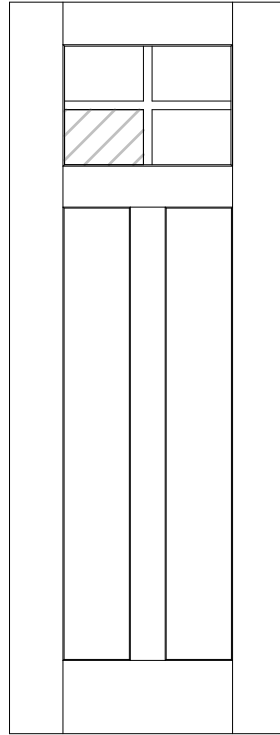

8' Craftsman Lite2 Panel Shaker  
Sidelite Flush-Glazed 2W2H

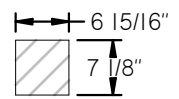
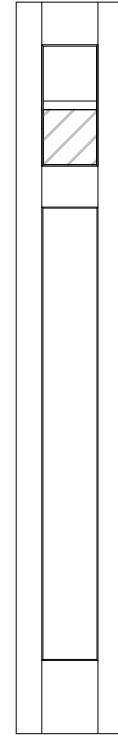

8' Craftsman Lite 2 Panel Shaker  
Flush-Glazed 3WIH

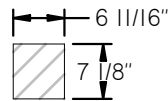
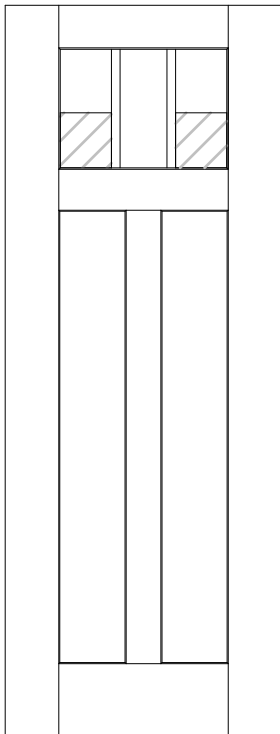

8' Craftsman Lite 2 Panel Shaker  
Flush-Glazed 3W2H

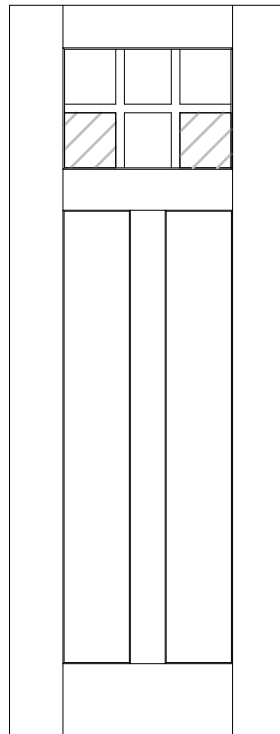



Full Lite  
Flush-Glazed IW3H

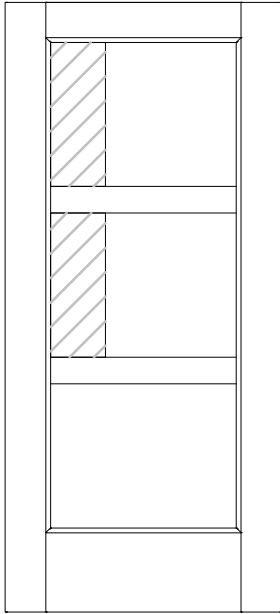

Full Lite Sidelite  
Flush-Glazed 08x64 IW3H

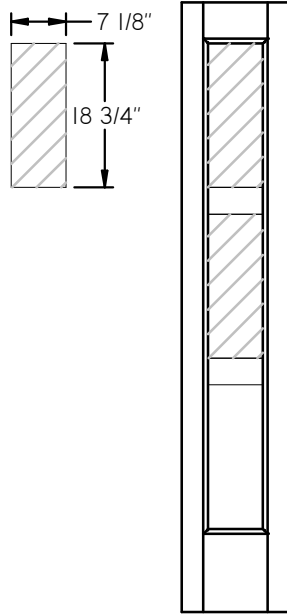

Full Lite Sidelite  
Flush-Glazed 07x64 IW3H

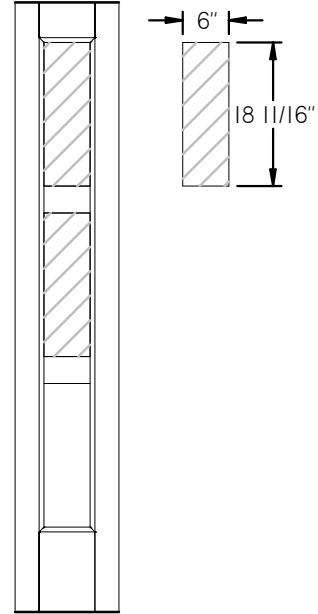

Full Lite  
Flush-Glazed IW4H

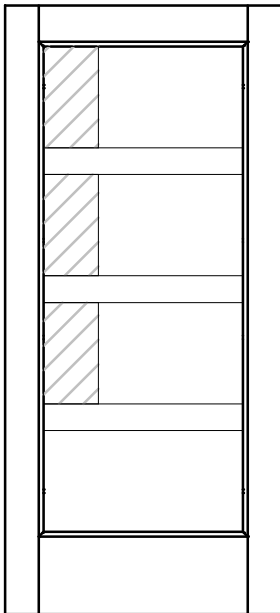

Full Lite Sidelite  
Flush-Glazed 08x64 IW4H

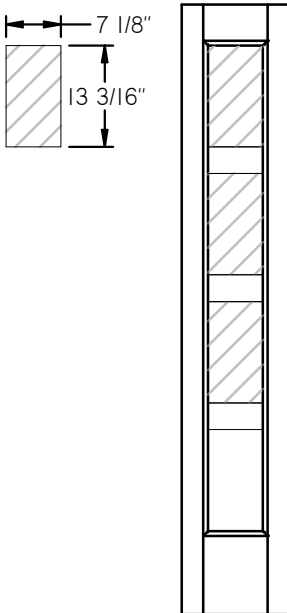

Full Lite Sidelite  
Flush-Glazed 07x64 IW4H

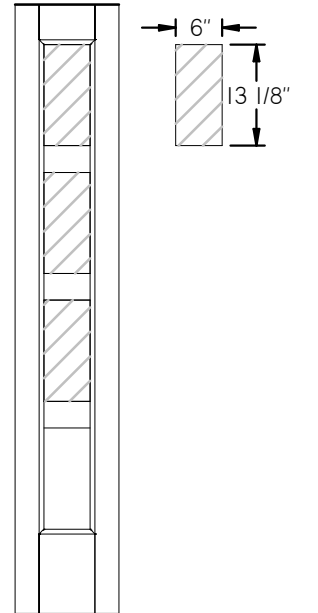

# SDL Bar Installation Instructions (Smooth Star / Fiber Classic)

Door  
Preparation

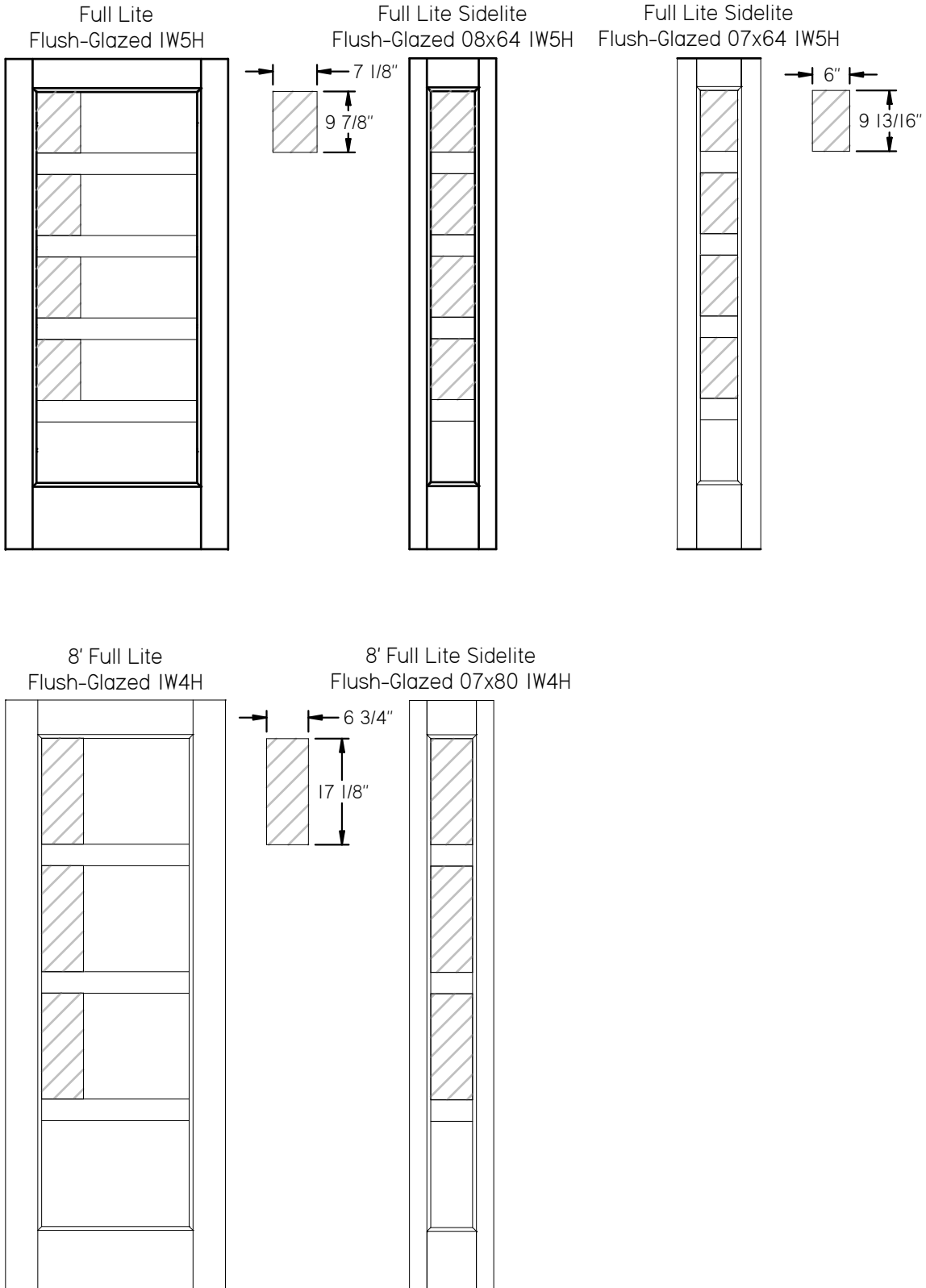

8' Full Lite  
Flush-Glazed IW5H

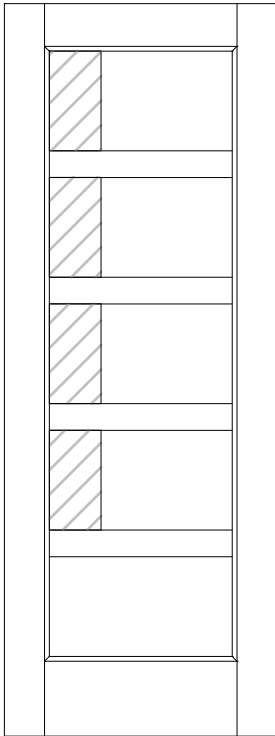

8' Full Lite Sidelite  
Flush-Glazed 07x80 IW5H

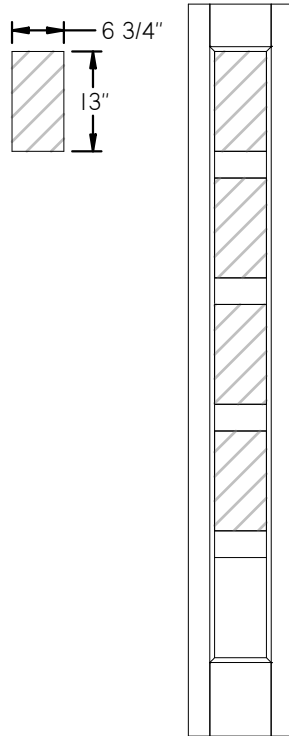

8' Full Lite  
Flush-Glazed IW6H

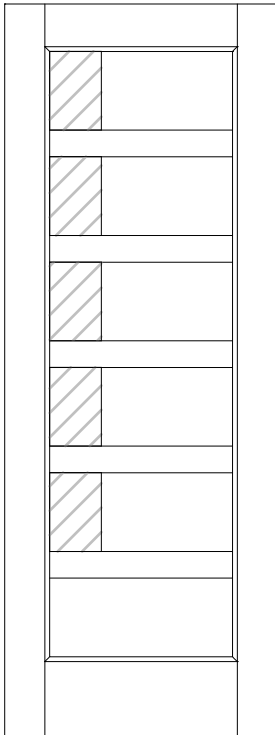

8' Full Lite Sidelite  
Flush-Glazed 07x80 IW6H

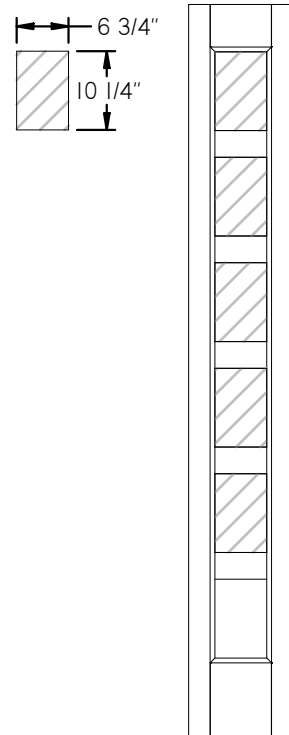

## Shop Installation Instructions for Dentil Shelf Attachment

The following instructions should be completed in the door shop or at the job site.

Check to see that the shelf shop pack is included with this unit. The pack contains all the necessary hardware and fasteners needed to complete this installation.

Read all instructions before starting.

**THERMA TRU**  
DOORS

Part Number: MACCASHELFINST REV. D

### 1 APPLY LOCATING TEMPLATE TO DOOR

Apply shelf locating template to door slab. Align all three sides of the template to ensure it is squared up with the door. Hold template down with clamps if needed.

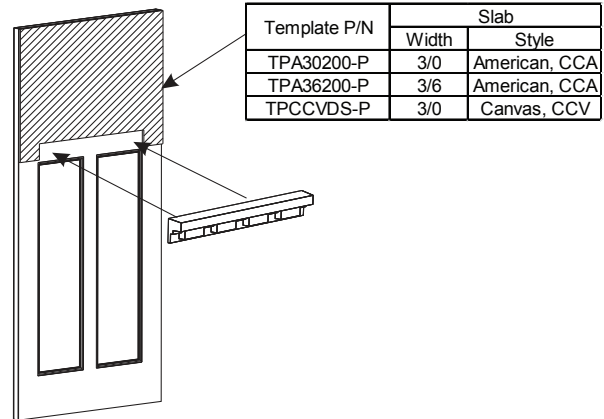

### 2 DRILL PILOT HOLES

After getting shelf aligned with the template, drill pilot holes with 1/8" drill bit at all three attachment locations into wood block on inside of the door.

Holes to be approximately 1/4" to 1/2" in depth.

**CAUTION:**

**DO NOT DRILL THROUGH ENTIRE DOOR.**

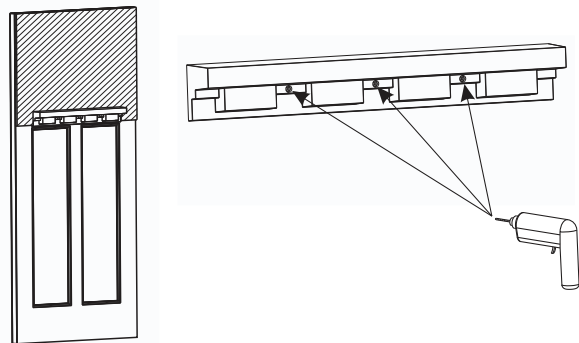

**3 FASTEN SHELF TO DOOR**

Fasten three screws into door at screw boss locations until shelf becomes tight with door. **DO NOT OVER TIGHTEN.**

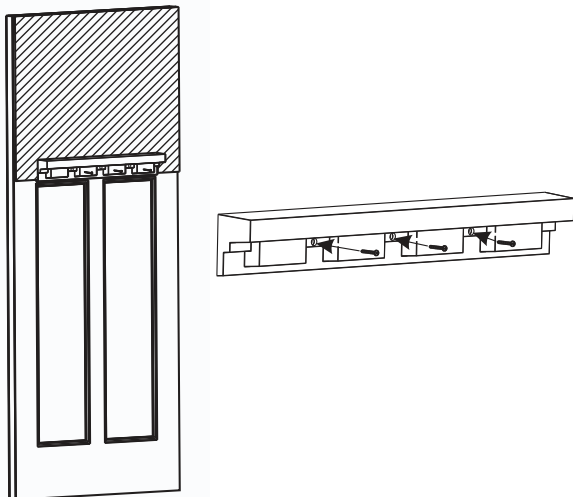

**4 INSERT PLUGS**

Align grain and insert plugs into holes. Press until plug is flush with shelf surface.

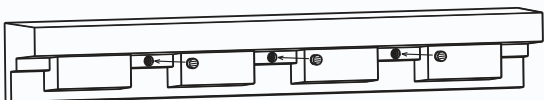

DISCLAIMER: SHELF IS NOT INTENDED TO HOLD ANY OBJECTS OR WEIGHT.

**Shelf Installation Components**

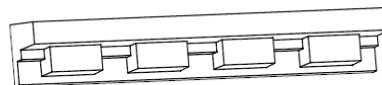

DENTIL SHELF  
CCADS04

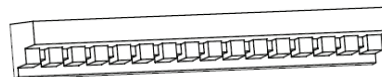

DENTIL SHELF  
CCADS16

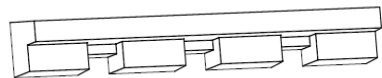

DENTIL SHELF  
CCVDS04

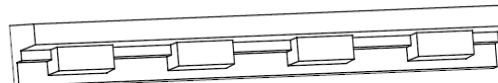

DENTIL SHELF  
CCA36DS04

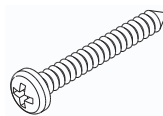

Shelf Screw  
(3) #10 x 1-1/2"  
Phillips Pan Head



Shelf Plug  
(3) Plugs  
CCAPLUG

**THERMA TRU**  
DOORS

P.O. Box 8780  
Maumee, Ohio 43537  
419-891-7400

Therma-Tru is a registered trademark of Therma-Tru Corp.  
© 2014 Therma-Tru Corp.

## **IMPORTANT:**

*Please read and understand all installation and adhesive instructions prior to opening the adhesive cartridge.*

**CAUTION:** Make sure your work area is well ventilated. Keep adhesive away from heat and flame. Avoid any contact with the eyes and skin. Read warning label on adhesive box. KEEP OUT OF REACH OF CHILDREN.

**NOTES:**

- When PAINTING, the door and dentil shelf should be unfinished when applying dentil shelf.
- When STAINING, the door and dentil shelf should be finished before applying the dentil shelf
- To be removed from the opening and placed in a horizontal position for a minimum of twenty-four hours to allow the adhesive to cure.
- Recommended application temperature minimum 40°F.

**TOOLS NEEDED:** Safety Glasses, Latex Gloves, Mineral Spirits, Isopropyl Alcohol

## **INSTALLATION:**

### **STEP 1: PREPARE THE DOOR**

Protect the underside of the door by laying it flat on padded sawhorses or another padded surface. Position the door with the exterior side facing up. Thoroughly clean the door surface and the dentil shelf with isopropyl alcohol. Surface must be completely dry before going on to Step 2.

### **STEP 2: LOCATE SHELF**

Position the dentil shelf on the door so that it is centered along the width of the door and parallel to the glass opening (suggested location is 3/8" from the bottom of the glass). With a graphite pencil, lightly mark the locations of the top and sides of the shelf on the door face.

### **STEP 3: APPLY ADHESIVE**

Open adhesive cartridge apply a single 1/4" diameter bead of adhesive to the center of the wood core on the underside of the shelf. Be careful not to allow adhesive beyond the wood to help prevent squeeze-out. Carefully press the shelf onto the door face using your pencil lines (from Step 2) as your locating guides. Apply firm pressure to ensure contact with door. You will have approximately 30 minutes to work with the shelf before the adhesive starts to set. Immediately remove any adhesive squeeze-out with mineral spirits and a clean cloth.

### **STEP 4: CURE TIME**

The shelf and door should remain in the horizontal position for a minimum of twenty four (24) hours to allow the adhesive to cure. After this time, the door can be finished and installed.

### **STEP 5: ADHESIVE DISPOSAL**

Wipe tip clean, and recap the product. Refer to MSDS on manufacturer's website.

## **DISCLAIMERS:**

- **SHELF IS NOT INTENDED TO HOLD ANY OBJECTS OR WEIGHT.**
- **THE SHELF IS NOT RECOMMENDED FOR USE BEHIND A STORM DOOR.**

## Attach Rain Deflector



Sealant type must be a paintable or stainable elastomeric or polyurethane.

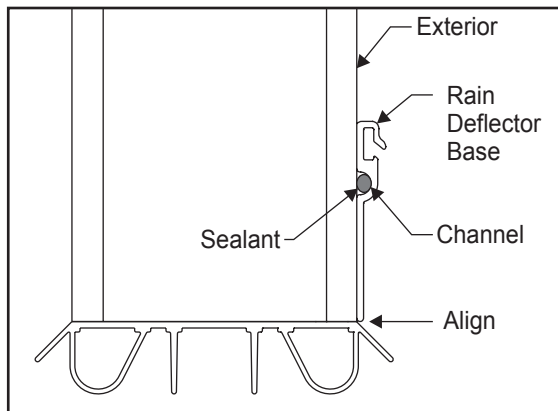

Center rain deflector base on exterior face of panel and align edge of rain deflector base with bottom edge of panel.

Apply bead of sealant in channel on rain deflector base.

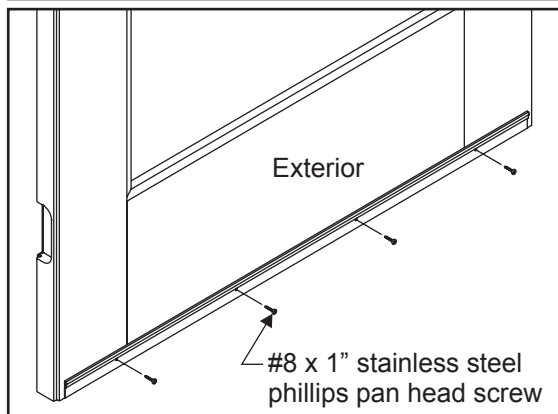

Attach rain deflector base to panel with #8 x 1" phillips pan head screws.

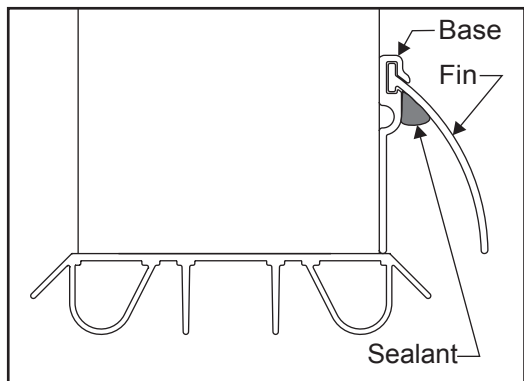

Slide rain deflector fin into channel on base.

Apply a 2" long bead of sealant up under the fin at the center of the door to prevent fin from sliding.

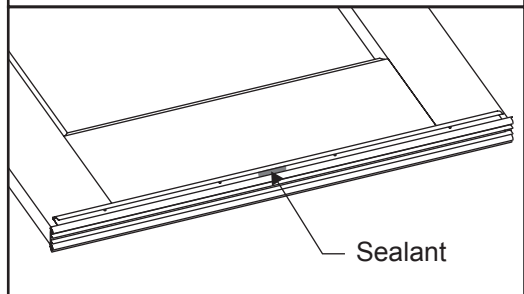

### Rain Deflector Cut Down Instructions:

- 3/0 - No cut down required.
- 2/10 - Cut 1" off both ends of 3/0 deflector.
- 2/8 - Cut 2" off both ends of 3/0 deflector.
- 2/6 - Cut 3" off both ends of 3/0 deflector.
- 2/4 - Cut 8" off one ends of 3/0 deflector.

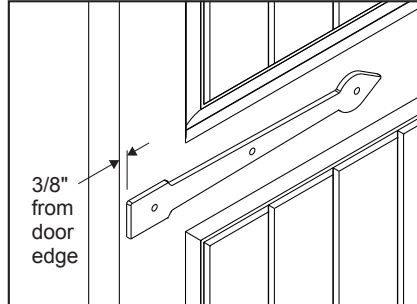

#### INSTALLATION:

1. Locate strap hinges 3/8" from edge of door at desired locations.
2. Using masking tape, mark the location of the strap hinges on the door.
3. Moisten a clean cloth with 70% Isopropyl Alcohol and clean the area where the hinges will be applied.
4. Remove backing tape from the tape on one hinge and attach it to the door.  
NOTE: Hinge cannot be moved once placed on the door.
5. Press the hinge firmly in place at the location of each tape backer. 35 pounds of force is required at each location.
6. Repeat for each other hinge.

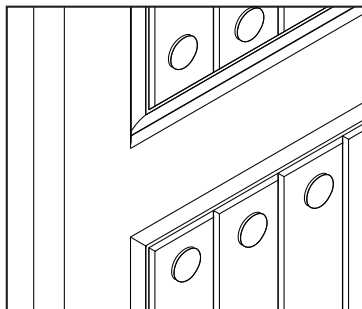

#### INSTALLATION:

1. Locate clavos on door at desired locations.
2. Using masking tape, mark the location of the clavos on the door.
3. Moisten a clean cloth with 70% Isopropyl Alcohol and clean the area where the clavos will be applied.
4. Remove backing tape from the tape on one clavos and attach it to the door.  
NOTE: clavos cannot be moved once placed on the door.
5. Press the clavos firmly in place at the location of the tape backer. 35 pounds of force is required.
6. Repeat for each clavos.



Clavos Examples

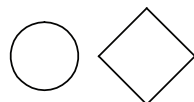
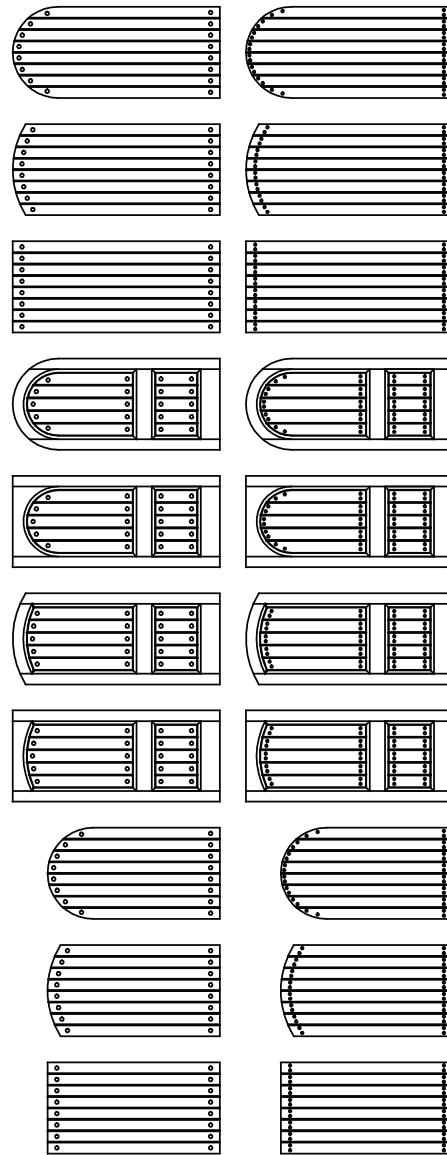
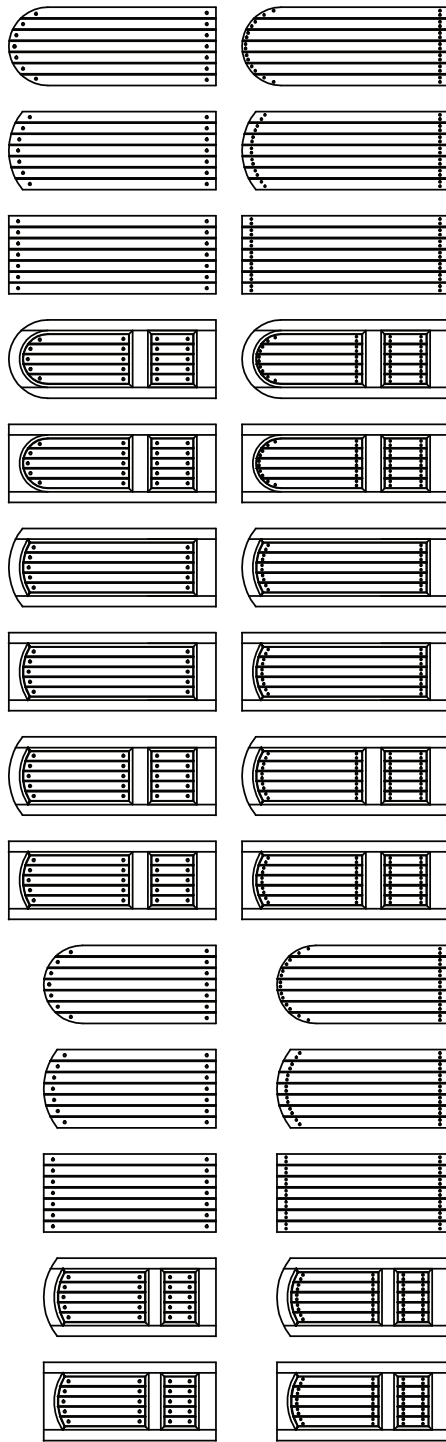

1 1/4" Round  
1 1/4" Square

3/0 Doors  
Single Clavos

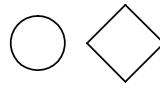

1" Round  
1" Square

3/0 Doors  
Double Clavos



1 3/4" Round  
1 1/2" Square

3/6 Doors  
Single Clavos



1 1/4" Round  
1 1/4" Square

3/6 Doors  
Double Clavos

# Decorative Hinge Strap & Clavos Application

Door  
Preparation

Strap Hinge Examples

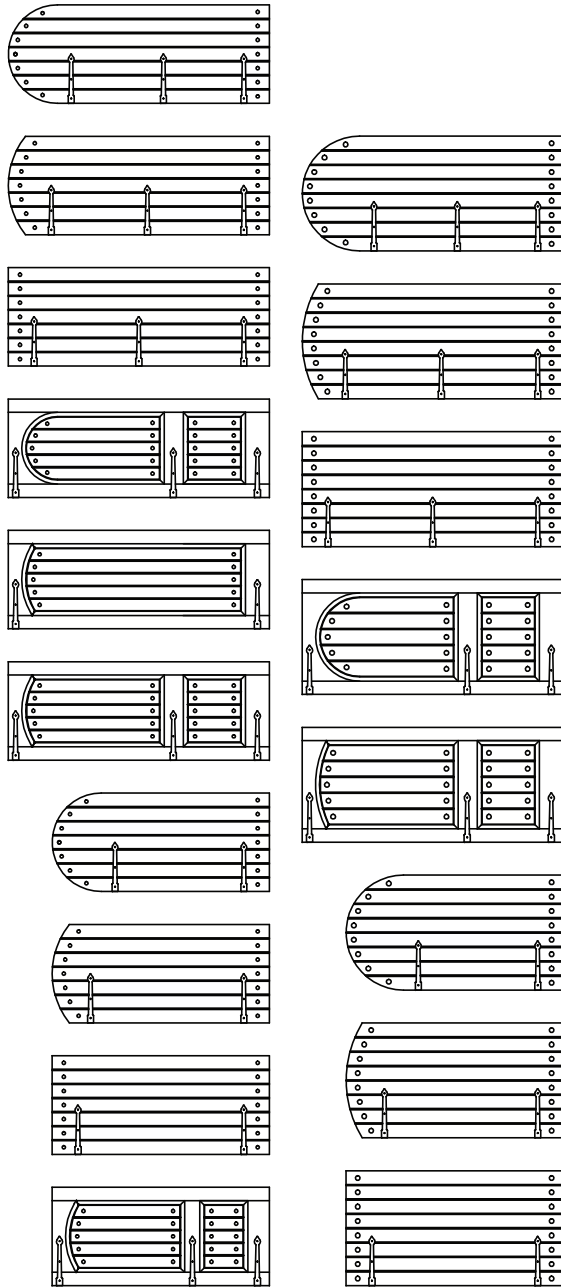

3/0 Doors

3/6 Doors

Other Door Styles with Hardware Examples

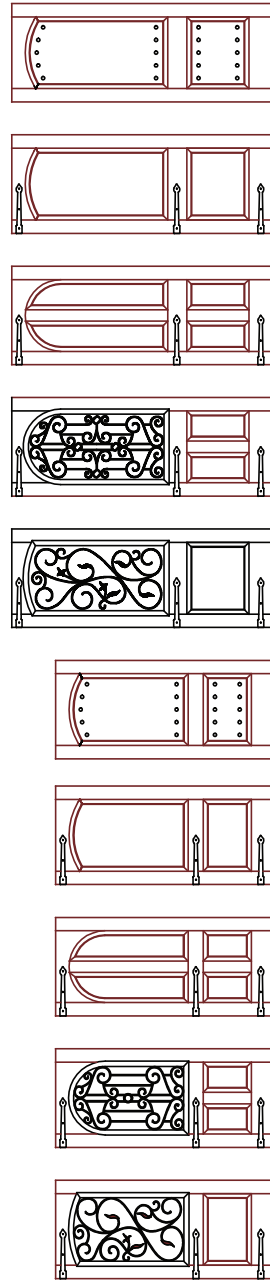

Therma-Tru products are manufactured for use with high quality, exterior grade house paints. See SITE 2 for standard finishing instructions. For distributor furnished prefinishing, use the following guidelines.

**CAUTION:**

Therma-Tru bears no responsibility for the performance of distributor-furnished prefinished doors.

Therma-Tru makes no claims about the compatibility of its primers when coated with special shop applied paints or topcoats.

**Finishing With Materials Other Than High Quality, Exterior Grade House Paints**

Automotive and industrial paints often contain stronger solvents than house paints. Because Therma-Tru's factory applied primer is intended for use with house paints, these stronger solvents may attack the factory applied primer. For best performance, we recommend:

**STEEL**

- Use a water-based acrylic paint, instead of an epoxy or urethane.
- If using an epoxy or urethane paint, first apply a primer over the factory applied finish. The primer will act as a barrier between the factory applied finish and the topcoat. The primer must, of course, be compatible with the topcoat being used.

**CLASSIC-CRAFT, FIBER-CLASSIC and SMOOTH-STAR DOORS**

- Use a water-based acrylic or alkyd-based (oil) paint, instead of an epoxy or urethane.
- Always apply a primer. The primer will act as a barrier between the factory finish and the topcoat. Use primers and topcoats that are compatible.
- Maximum temperature for quick dry should be 200°F or less.

## Peep Sights

Two examples of Peep sights are shown below.  
Peep sights vary by door style.  
Please contact technical service for specific door information.

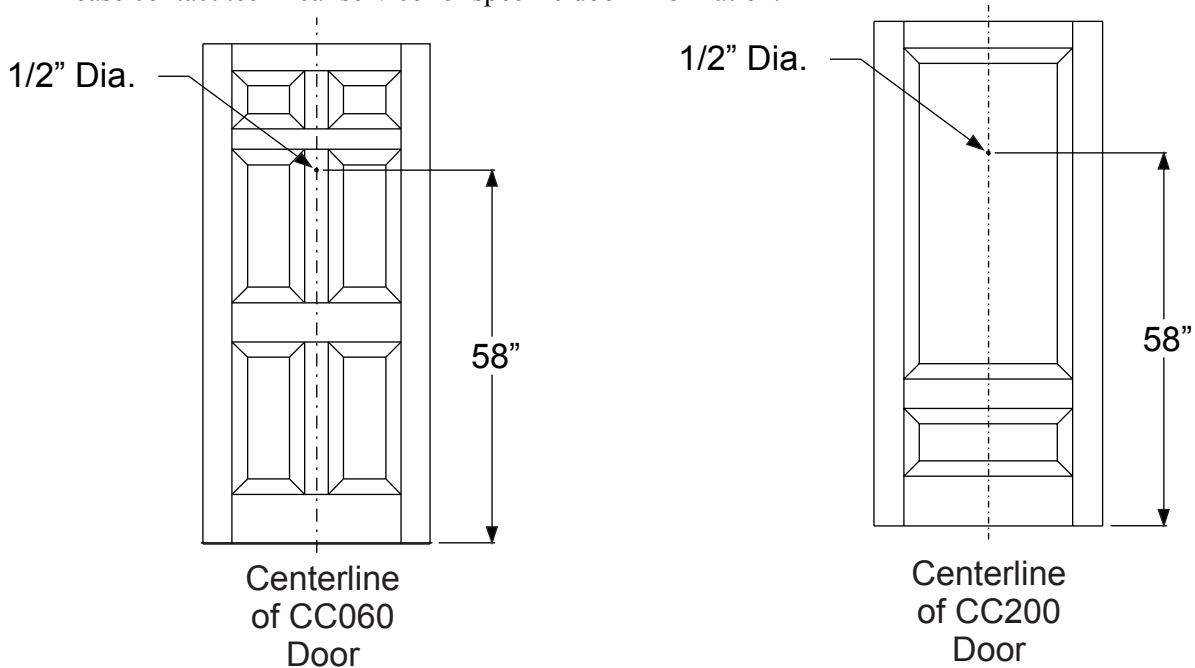

## Mail Slots

Two examples of Mail slot machining are shown below.  
Mail slot locations vary by door style.  
Please contact technical service for specific door information.

