

---

Equipment.....	2.3
Shop Layout.....	2.6



Below is a recommended list of equipment required for a millwork shop.

Air Compressor

Assembly Tables (see sketches on following pages)

Caulking Guns (manual or air-powered)

Drill Press (optional)

Miter Saw

Power Drill

Radial-Arm Saw

Screw Guns with torque-adjustable clutch

Shop Hand Tools - hammer, chisel, etc.

Staple Guns (various sizes)

Table Saw (sliding table preferred)

Special-purpose machinery (ex. KVAL, Norfield)

- Jamb lock preparation
- Jamb hinge preparation
- Door lite cutout (RUVO/Triad machines available from Therma-Tru)
- Door lock preparation
- Door edge planing and beveling

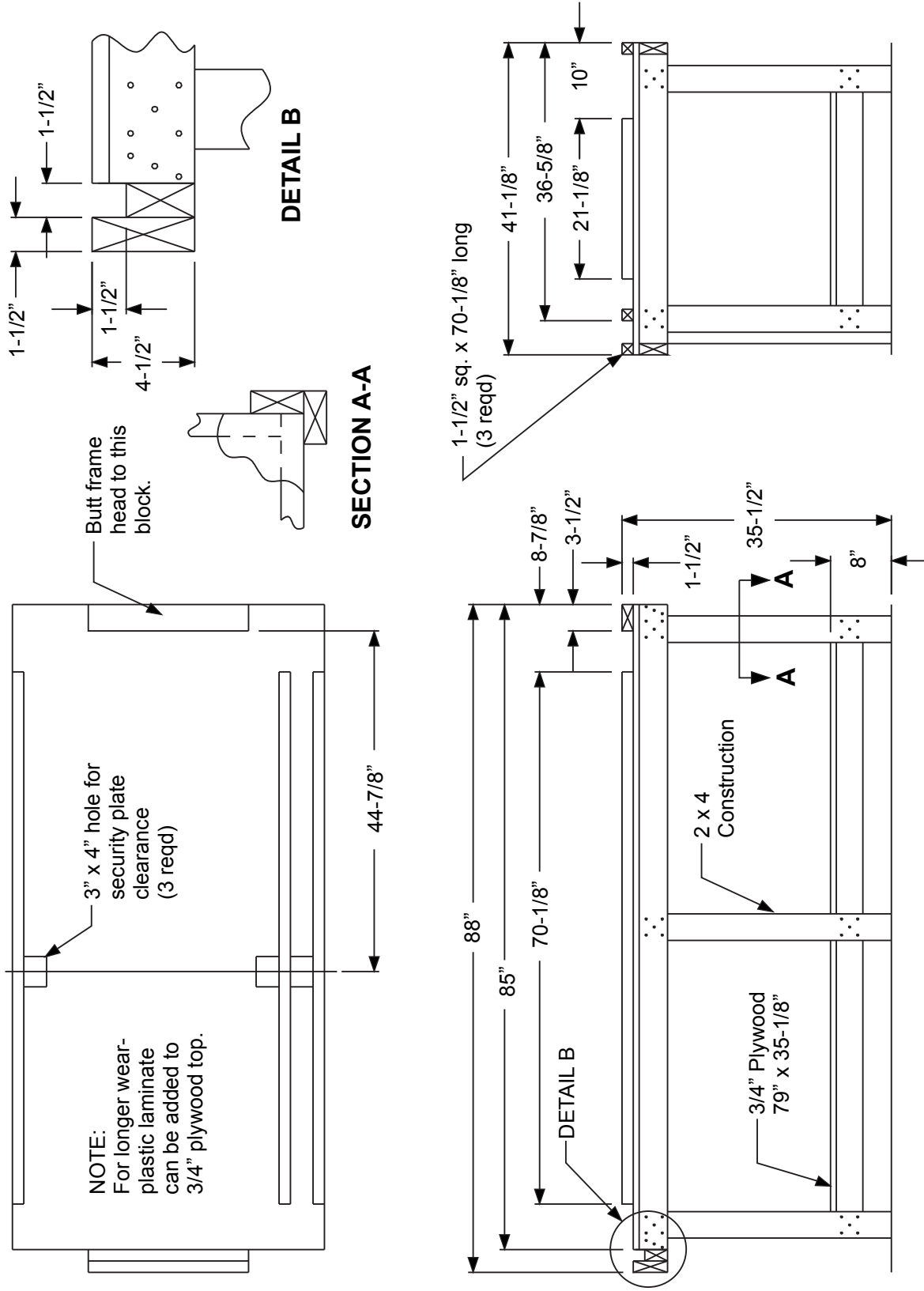

**DOOR FRAME ASSEMBLY TABLE**

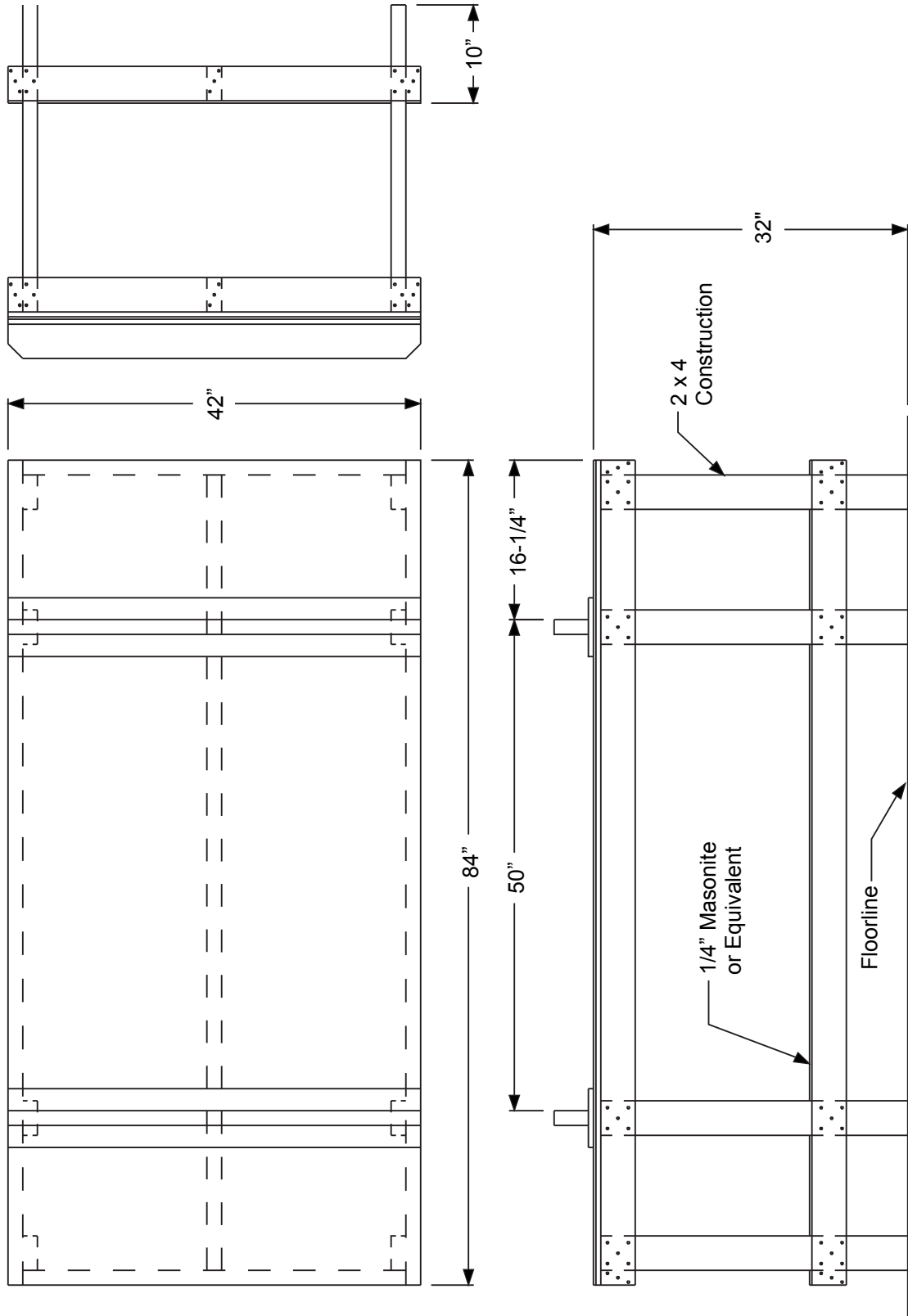

**DOOR LITE TABLE**

# Shop Layout

The following pages show three typical shop layouts recommended by Therma-Tru. They are an “L” and “U” shaped and “In-Line” configuration assembly line. Contact Therma-Tru if you need assistance on how your shop should be configured.

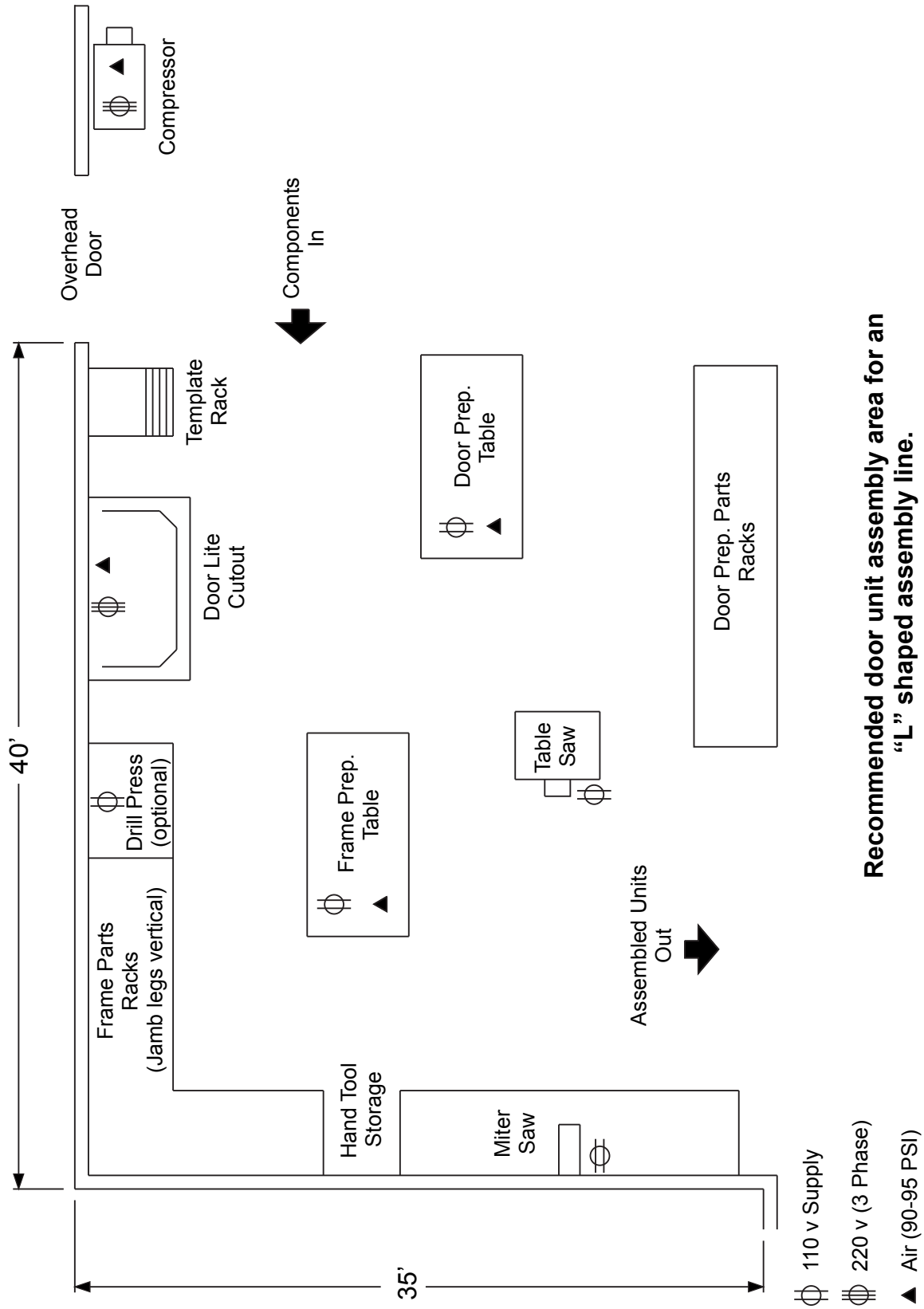

**Recommended door unit assembly area for an "L" shaped assembly line.**

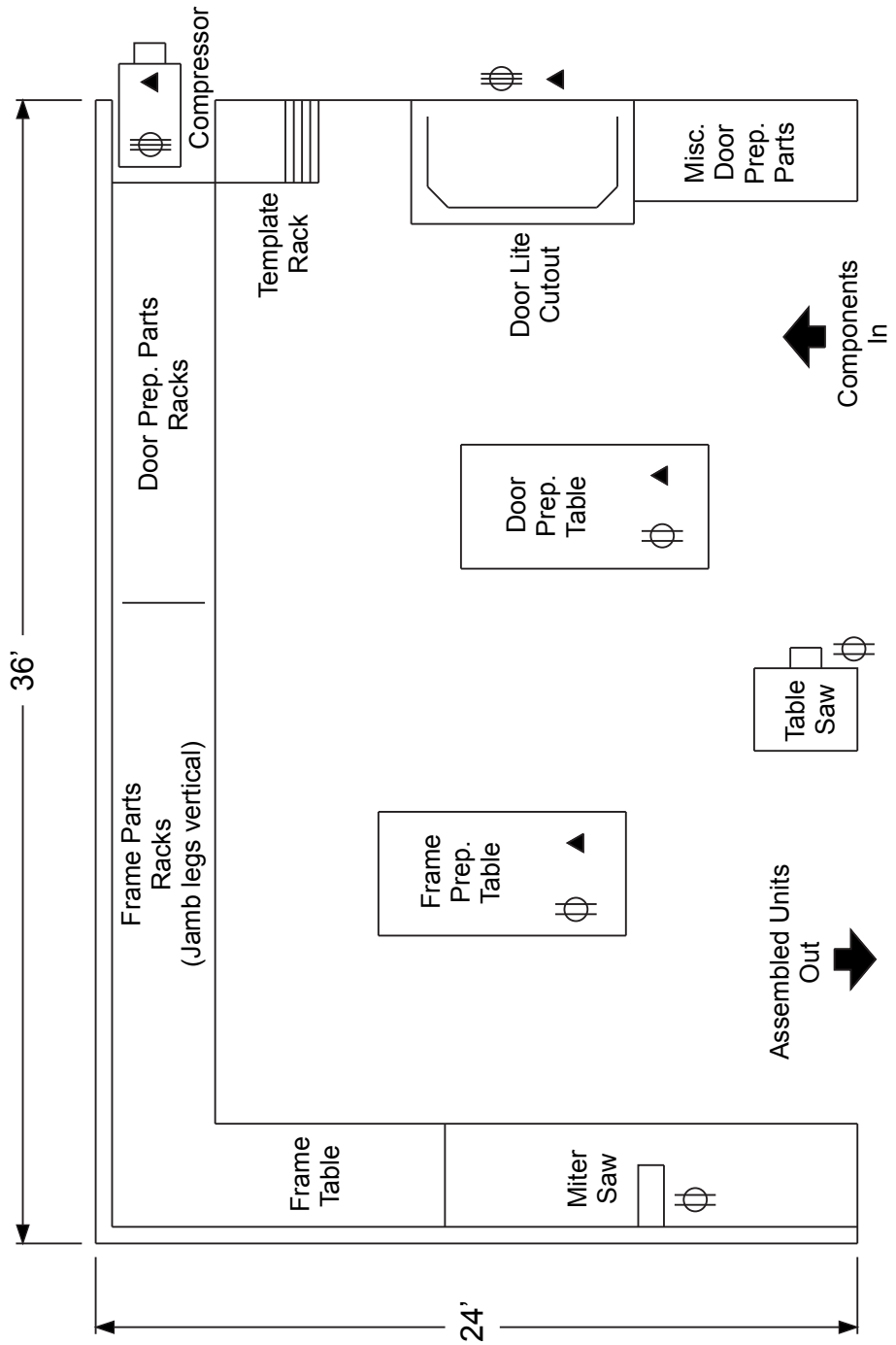

⊕ 110 v Supply

⊕⊕ 220 v (3 Phase)

▲ Air (90-95 PSI)

**Recommended door unit assembly area for a "U" shaped assembly line.**



