

Jamb Profiles	6.3
Head Jamb - Standard.....	6.4
Head Jamb - Arch and Radius.....	6.5
Head Jamb - Continuous with 1 Sidelite and Double Doors	6.6
Head Jamb - Triple and Single with 2 Sidelites	6.7
Head Jamb - French Continuous with 2 Sidelites	6.8
Head Jamb - Continuous with 1 or 2 Venting Sidelites.....	6.9
Head Jamb - Spread Mullion	6.10
Head Jamb - French Multipoint.....	6.11
Head Jamb - French Multipoint with 2 Venting Sidelites	6.12
Side Jamb.....	6.13
Mullions	6.19
Spread Mullion Jamb	6.25
Stainable & Standard Aluminum 7/8" Astragal.....	6.29
Coastal Astragal	6.31
Astragal - Outswing Security Cover	6.33
Brickmould.....	6.34
Cove Molding and Head Seal Pad.....	6.39
Mull Casing	6.40
Direct Set Sidelite	6.41

Frame Parts

Frame Parts

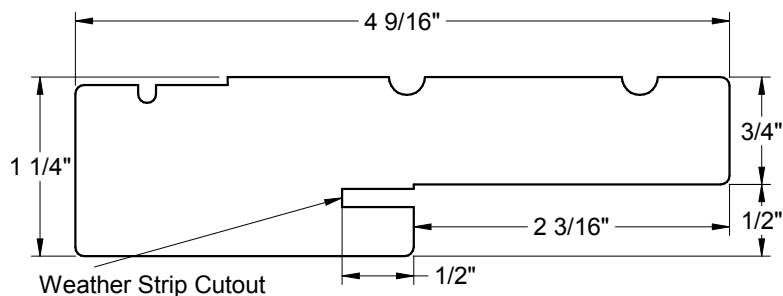

4-9/16" Jamb

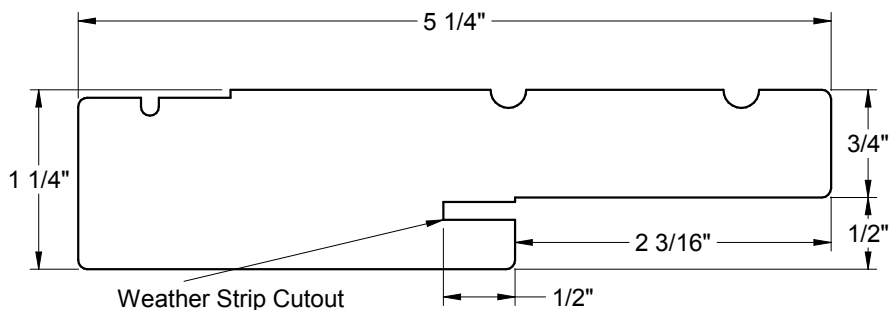

5-1/4" Jamb

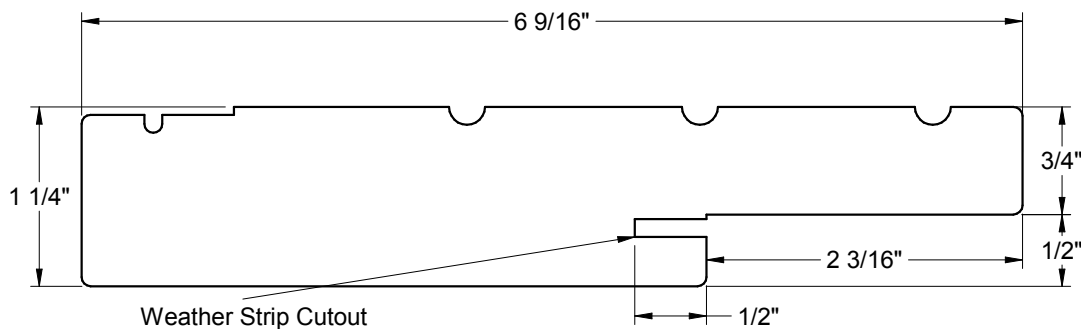

6-9/16" Jamb

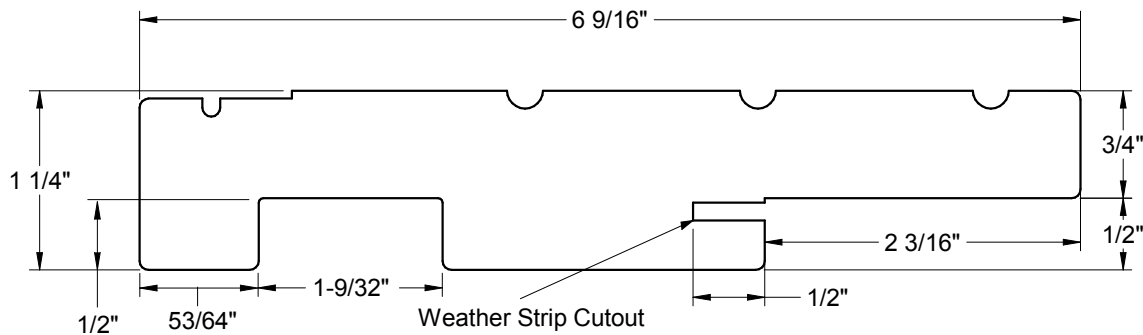

**6-9/16" Patio Jamb
(for sliding screens)**

Frame Parts

Head Jambs - Standard

UNIT SIZE	LENGTH "A"
10" SIDELITE	10.000
12" SIDELITE	12.000
14" SIDELITE	14.000
2/0 SIDELITE	24.000
2/0 DOOR	24.000
2/4 DOOR	28.000
2/6 DOOR	30.000
2/8 DOOR	32.000
2/10 DOOR	34.000
3/0 DOOR	36.000
3/6 DOOR	42.000
4/0 FRENCH 7/8" ASTRAGAL	48.718
4/8 FRENCH 7/8" ASTRAGAL	56.718
5/0 FRENCH 7/8" ASTRAGAL	60.718
5/4 FRENCH 7/8" ASTRAGAL	64.718
5/8 FRENCH 7/8" ASTRAGAL	68.718
6/0 FRENCH 7/8" ASTRAGAL	72.718
7/0 FRENCH 7/8" ASTRAGAL	84.718

Head Jamb

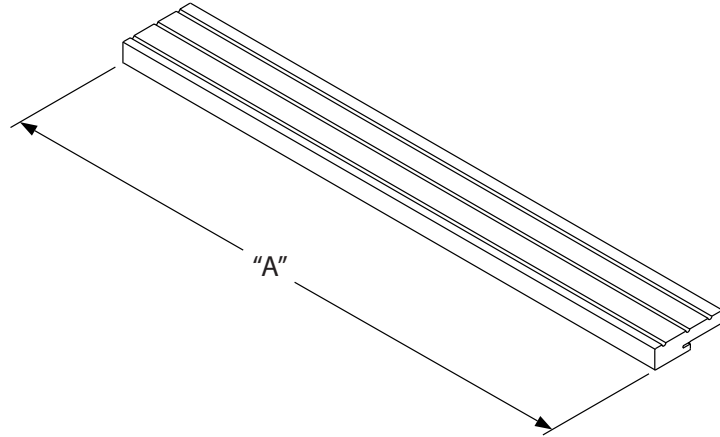

Frame Parts

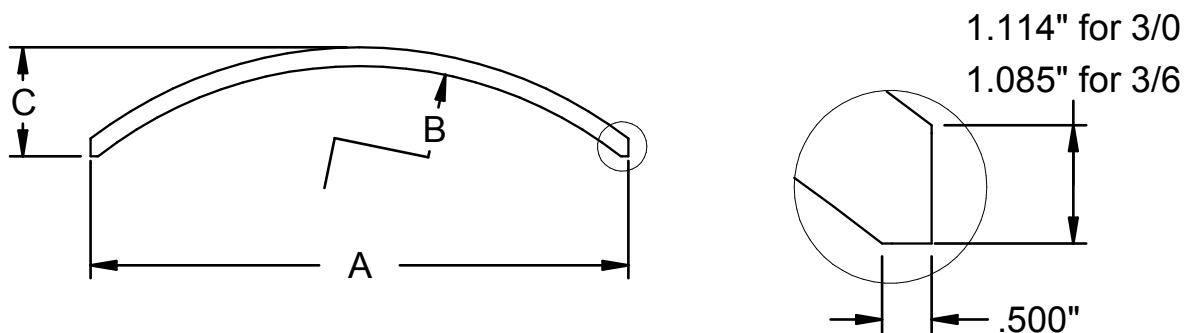
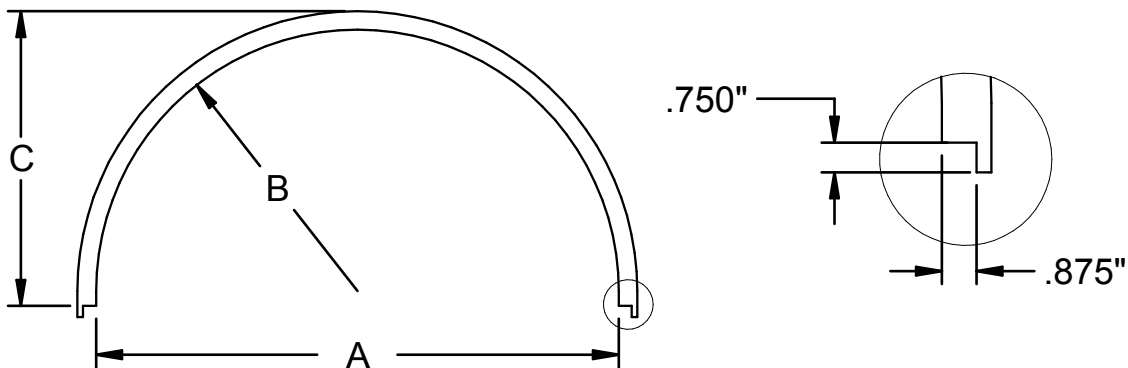

Frame Parts

UNIT SIZE	LENGTH "A"	RADIUS "B"	HEIGHT "C"
3/0 RADIUS	34.972"	17.486"	19.736"
3/6 RADIUS	40.968"	20.484"	22.734"
3/0 ARCH	35.968"	28.486"	7.247"
3/6 ARCH	41.968"	39.751"	6.934"

Head Jamb - Continuous with 1 Sidelite and Double Doors

Inswing Active Left Shown

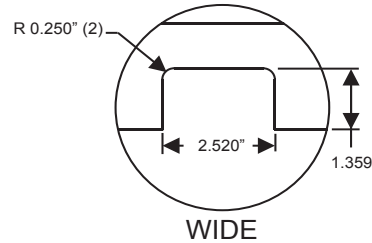
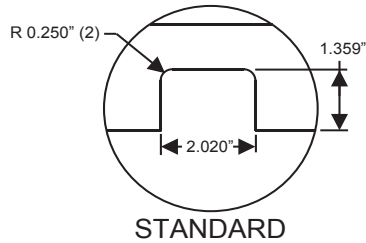
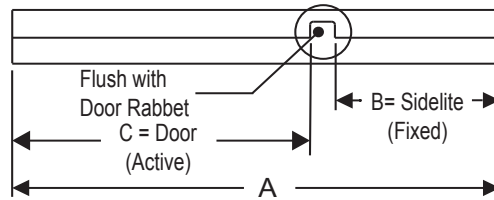

Frame Parts

CONTINUOUS WITH 1 SIDELITE						
	STANDARD MULLION			WIDE MULLION		
	A	B	C	A	B	C
2/4 W/1-10" SL	39.000	9.490	27.490	39.500	9.490	27.490
2/4 W/1-12" SL	41.000	11.490		41.500	11.490	
2/4 W/1-14" SL	43.000	13.490		43.500	13.490	
2/6 W/1-10" SL	41.000	9.490	29.490	41.500	9.490	29.490
2/6 W/1-12" SL	43.000	11.490		43.500	11.490	
2/6 W/1-14" SL	45.000	13.490		45.500	13.490	
2/8 W/1-10" SL	43.000	9.490	31.490	43.500	9.490	31.490
2/8 W/1-12" SL	45.000	11.490		45.500	11.490	
2/8 W/1-14" SL	47.000	13.490		47.500	13.490	
2/10 W/1-10" SL	45.000	9.490	33.490	45.500	9.490	33.490
2/10 W/1-12" SL	47.000	11.490		47.500	11.490	
2/10 W/1-14" SL	49.000	13.490		49.500	13.490	
3/0 W/1-10" SL	47.000	9.490	35.490	47.500	9.490	35.490
3/0 W/1-12" SL	49.000	11.490		49.500	11.490	
3/0 W/1-14" SL	51.000	13.490		51.500	13.490	
3/6 W/1-10" SL	53.000	9.490	41.490	53.500	9.490	41.490
3/6 W/1-12" SL	55.000	11.490		55.500	11.490	
3/6 W/1-14" SL	57.000	13.490		57.500	13.490	

DOUBLE DOOR						
	STANDARD MULLION			WIDE MULLION		
	A	B	C	A	B	C
4/8 DOUBLE MULLION	57.000	27.490	27.490	57.500	27.490	27.490
5/0 DOUBLE MULLION	61.000	29.490	29.490	61.500	29.490	29.490
5/4 DOUBLE MULLION	65.000	31.490	31.490	65.500	31.490	31.490
5/8 DOUBLE MULLION	69.000	33.490	33.490	69.500	33.490	33.490
6/0 DOUBLE MULLION	73.000	35.490	35.490	73.500	35.490	35.490

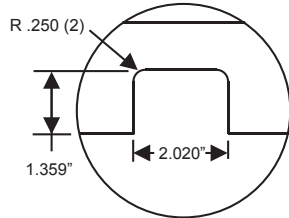
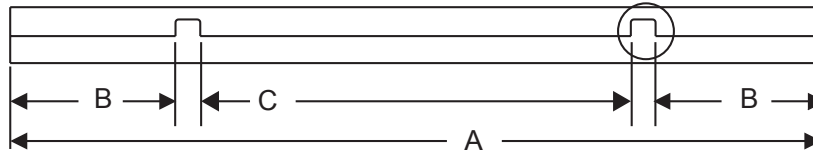

STANDARD

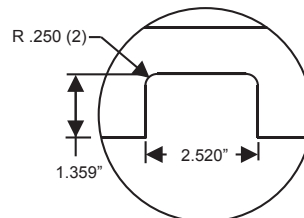

WIDE

TRIPLE AND SINGLE WITH 2 SIDELITES							
		STANDARD MULLION			WIDE MULLION		
		A	B	C	A	B	C
TRIPLE UNITS	7/0 TRIPLE	86.000	27.490	26.980	87.000	27.490	26.980
	7/6 TRIPLE	92.000	29.490	28.980	93.000	29.490	28.980
	8/0 TRIPLE	98.000	31.490	30.980	99.000	31.490	30.980
	8/6 TRIPLE	104.000	33.490	32.980	105.000	33.490	32.980
	9/0 TRIPLE	110.000	35.490	34.980	111.000	35.490	34.980
	10/6 TRIPLE	128.000	41.490	40.980	129.000	41.490	40.980
CONTINUOUS WITH 2 SIDELITES	2/4 W/2-10" SL	50.000	9.490	26.980	51.000	9.490	26.980
	2/4 W/2-12" SL	54.000	11.490		55.000	11.490	
	2/4 W/2-14" SL	58.000	13.490		59.000	13.490	
	2/6 W/2-10" SL	52.000	9.490	28.980	53.000	9.490	28.980
	2/6 W/2-12" SL	56.000	11.490		57.000	11.490	
	2/6 W/2-14" SL	60.000	13.490		61.000	13.490	
	2/8 W/2-10" SL	54.000	9.490	30.980	55.000	9.490	30.980
	2/8 W/2-12" SL	58.000	11.490		59.000	11.490	
	2/8 W/2-14" SL	62.000	13.490		63.000	13.490	
	2/10 W/2-10" SL	56.000	9.490	32.980	57.000	9.490	32.980
	2/10 W/2-12" SL	60.000	11.490		61.000	11.490	
	2/10 W/2-14" SL	64.000	13.490		65.000	13.490	
	3/0 W/2-10" SL	58.000	9.490	34.980	59.000	9.490	34.980
	3/0 W/2-12" SL	62.000	11.490		63.000	11.490	
	3/0 W/2-14" SL	66.000	13.490		67.000	13.490	
3/6 W/2-10" SL	64.000	9.490	40.980	65.000	9.490	40.980	
3/6 W/2-12" SL	68.000	11.490		69.000	11.490		
3/6 W/2-14" SL	72.000	13.490		73.000	13.490		

Frame Parts

Head Jamb - French Continuous with 2 Sidelites

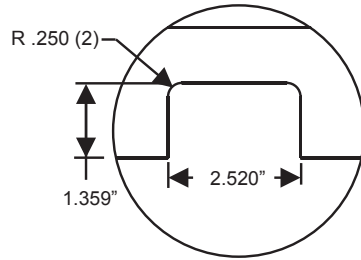
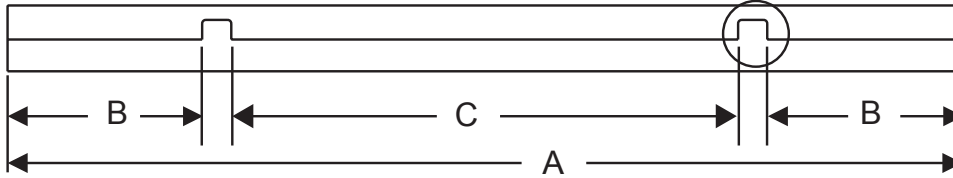

Frame Parts

CONTINUOUS - FRENCH WITH 7/8" ASTRAGAL AND 2 FIXED SIDELITES - WIDE MULLION			
	A	B	C
6/0 W/2-10" SL	95.718	9.49	71.698
6/0 W/2-12" SL	99.718	11.49	
6/0 W/2-14" SL	103.718	13.49	

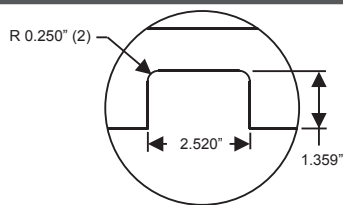
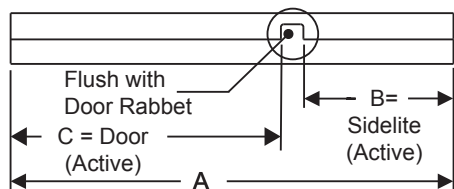

CONTINUOUS WITH 1 VENTING SIDELITE			
	WIDE MULLION		
	A	B	C
2/4 W/1-12" VENTING SL	41.721	11.677	27.524
2/4 W/1-14" VENTING SL	43.721	13.677	
2/6 W/1-12" VENTING SL	43.721	11.677	29.524
2/6 W/1-14" VENTING SL	45.721	13.677	
2/8 W/1-12" VENTING SL	45.721	11.677	31.524
2/8 W/1-14" VENTING SL	47.721	13.677	
2/10 W/1-12" VENTING SL	47.721	11.677	33.524
2/10 W/1-14" VENTING SL	49.721	13.677	
3/0 W/1-12" VENTING SL	49.721	11.677	35.524
3/0 W/1-14" VENTING SL	51.721	13.677	

Frame Parts

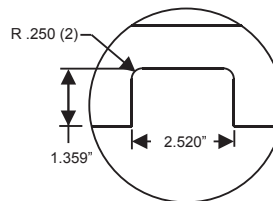
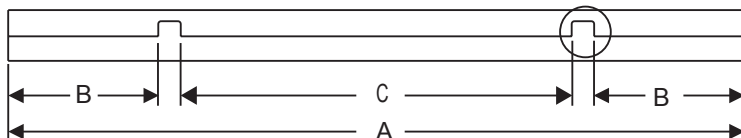

CONTINUOUS WITH 2 VENTING SIDELITES				
		WIDE MULLION		
		A	B	C
SINGLE	2/4 SINGLE W/2-12" VENTING SL	55.408	11.677	27.014
	2/4 SINGLE W/2-14" VENTING SL	59.408	13.677	
	2/6 SINGLE W/2-12" VENTING SL	57.408	11.677	29.014
	2/6 SINGLE W/2-14" VENTING SL	61.408	13.677	
	2/8 SINGLE W/2-12" VENTING SL	59.408	11.677	31.014
	2/8 SINGLE W/2-14" VENTING SL	63.408	13.677	
	2/10 SINGLE W/2-12" VENTING SL	61.408	11.677	33.014
	2/10 SINGLE W/2-14" VENTING SL	65.408	13.677	
	3/0 SINGLE W/2-12" VENTING SL	63.408	11.677	35.014
3/0 SINGLE W/2-14" VENTING SL	67.408	13.677		
FRENCH	4/8 FRENCH W/2-12" VENTING SL	84.126	11.677	55.732
	4/8 FRENCH W/2-14" VENTING SL	88.126	13.677	
	5/0 FRENCH W/2-12" VENTING SL	88.126	11.677	59.732
	5/0 FRENCH W/2-14" VENTING SL	92.126	13.677	
	5/4 FRENCH W/2-12" VENTING SL	92.126	11.677	63.732
	5/4 FRENCH W/2-14" VENTING SL	96.126	13.677	
	5/8 FRENCH W/2-12" VENTING SL	96.126	11.677	67.732
	5/8 FRENCH W/2-14" VENTING SL	100.126	13.677	
	6/0 FRENCH W/2-12" VENTING SL	100.126	11.677	71.732
	6/0 FRENCH W/2-14" VENTING SL	104.126	13.677	

Head Jamb - Spread Mullion

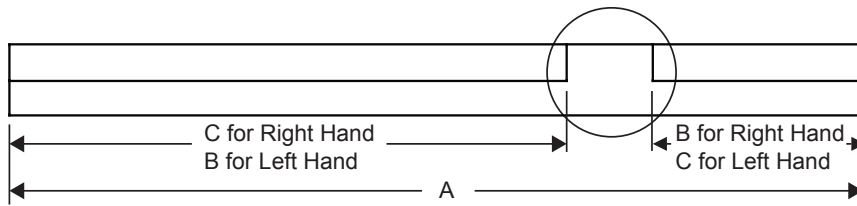

		SPREAD MULLION													
		LENGTH "A"													
UNIT SIZE	"C"	"B"	S000	S025	S050	S075	S100	S125	S150	S175	S200	S225	S250	S275	S300
3/0 W/ 1-10" SIDELITE	35.490	9.490	47.500	47.750	48.000	48.250	48.500	48.750	49.000	49.250	49.500	49.750	50.000	50.250	50.500
3/0 W/ 1-12" SIDELITE		11.490	49.500	49.750	50.000	50.250	50.500	50.750	51.000	51.250	51.500	51.750	52.000	52.250	52.500
3/0 W/ 1-14" SIDELITE		13.490	51.500	51.750	52.000	52.250	52.500	52.750	53.000	53.250	53.500	53.750	54.000	54.250	54.500

Frame Parts

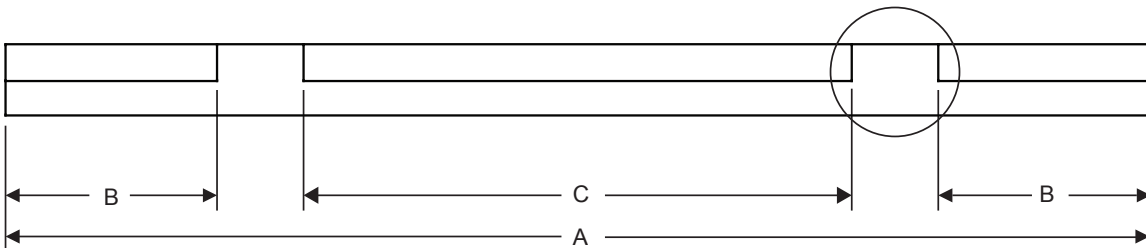

		SPREAD MULLION													
		LENGTH "A"													
UNIT SIZE	"C"	"B"	S000	S025	S050	S075	S100	S125	S150	S175	S200	S225	S250	S275	S300
3/0 W/ 2-10" SIDELITES	34.980	9.490	59.000	59.500	60.000	60.500	61.000	61.500	62.000	62.500	63.000	63.500	64.000	64.500	65.000
3/0 W/ 2-12" SIDELITES		11.490	63.000	63.500	64.000	64.500	65.000	65.500	66.000	66.500	67.000	67.500	68.000	68.500	69.000
3/0 W/ 2-14" SIDELITES		13.490	67.000	67.500	68.000	68.500	69.000	69.500	70.000	70.500	71.000	71.500	72.000	72.500	73.000

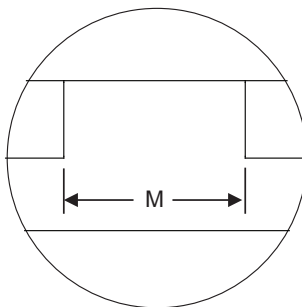

WIDTH "M"												
S000	S025	S050	S075	S100	S125	S150	S175	S200	S225	S250	S275	S300
2.520	2.770	3.020	3.270	3.520	3.770	4.020	4.270	4.520	4.770	5.020	5.270	5.520

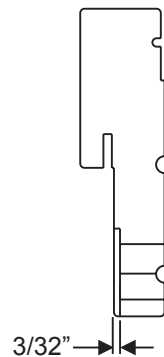
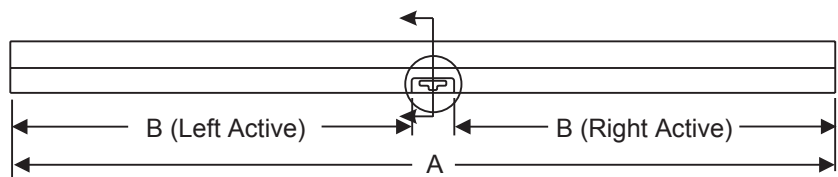

FRENCH DOOR WITH MULTI-POINT LOCK			
		A	B
7/8" ASTRAGAL	4/0 FRENCH	48.718	21.583
	4/8 FRENCH	56.718	25.583
	5/0 FRENCH	60.718	27.583
	5/4 FRENCH	64.718	29.583
	5/8 FRENCH	68.718	31.583
	6/0 FRENCH	72.718	33.583
	7/0 FRENCH	84.718	39.583

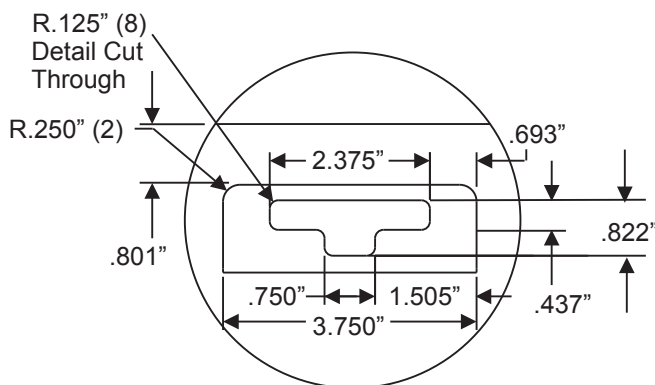

Standard MPLS

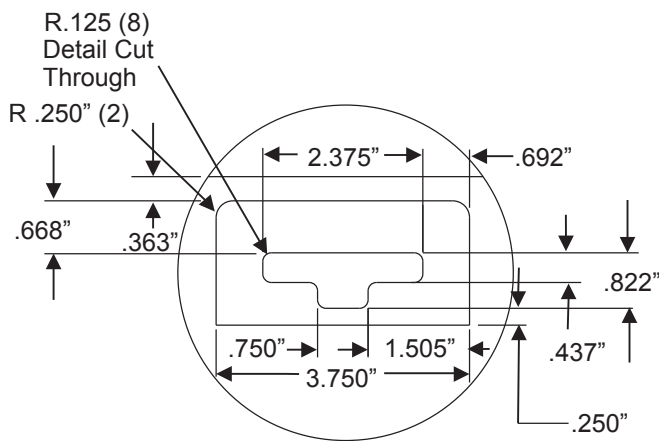

Impact MPLS

Frame Parts

Head Jamb - French Multipoint with 2 Venting Sidelites

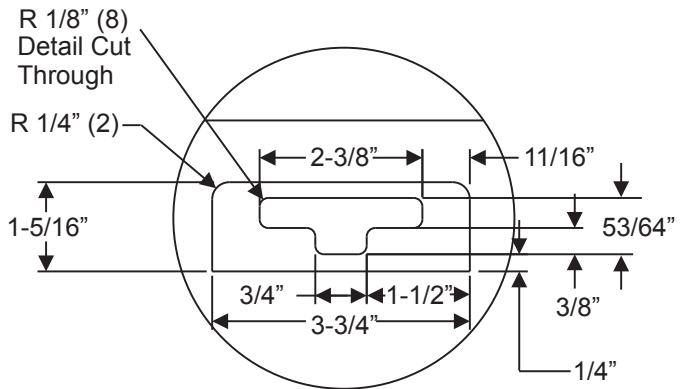
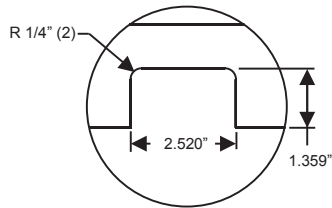
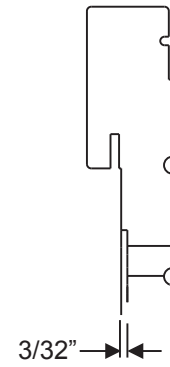
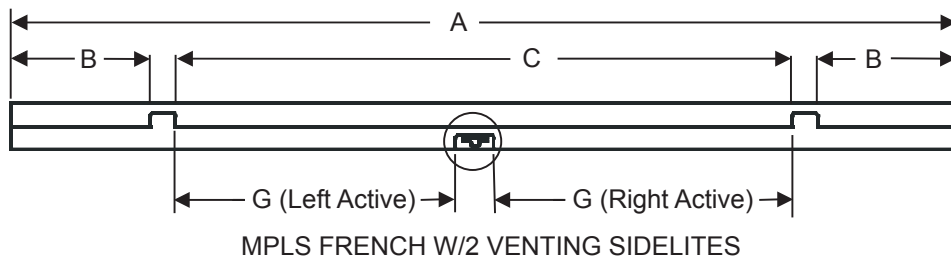

Frame Parts

CONTINUOUS WITH 2 VENTING SIDELITES					
		WIDE MULLION			
		A	B	C	G
7/8" ASTRAGAL	4/8 FRENCH W/2-12" VENTING SL	84.126	11.677	55.732	25.106
	4/8 FRENCH W/2-14" VENTING SL	88.126	13.677	55.732	25.106
	5/0 FRENCH W/2-12" VENTING SL	88.126	11.677	59.732	27.106
	5/0 FRENCH W/2-14" VENTING SL	92.126	13.677	59.732	27.106
	5/4 FRENCH W/2-12" VENTING SL	92.126	11.677	63.732	29.106
	5/4 FRENCH W/2-14" VENTING SL	96.126	13.677	63.732	29.106
	5/8 FRENCH W/2-12" VENTING SL	96.126	11.677	67.732	31.106
	5/8 FRENCH W/2-14" VENTING SL	100.126	13.677	67.732	31.106
	6/0 FRENCH W/2-12" VENTING SL	100.126	11.677	71.732	33.106
	6/0 FRENCH W/2-14" VENTING SL	104.126	13.677	71.732	33.106

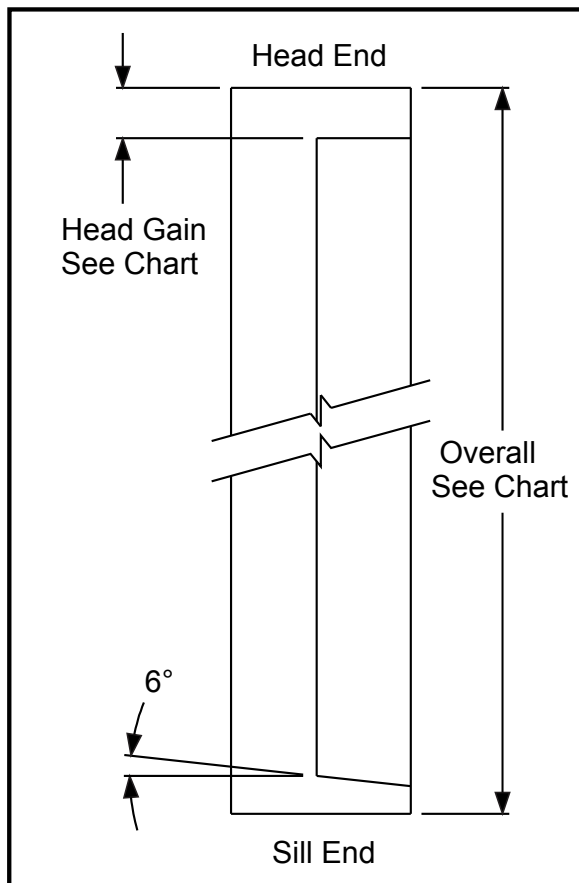

UNIT SIZE	LENGTH "A"	HEAD GAIN "B"
6/6	79.280"	1.250"
6/8	81.828"	1.250"
7/0	85.828"	1.250"
8/0	97.828"	1.250"
6/8 3/0 ARCH	76.151"	1.570"
6/8 3/6 ARCH	76.385"	1.491"
8/0 3/0 ARCH	92.151"	1.570"
8/0 3/6 ARCH	92.385"	1.491"
6/8 3/0 RADIUS	62.092"	See Figure Below
6/8 3/6 RADIUS	59.092"	
8/0 3/0 RADIUS	78.092"	
8/0 3/6 RADIUS	75.092"	

Frame Parts

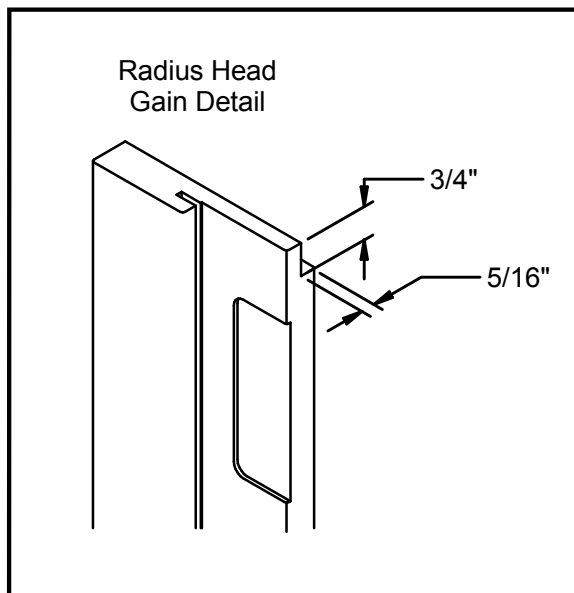

Side Jambs

		HINGE MORTISE LOCATIONS				
		UNIT SIZE	HINGE [1]	HINGE [2]	HINGE [3]	HINGE [4]
STANDARD HINGE	UNDERSIZE	6/6	9.125	38.875	68.625	N/A
		6/8				
		7/0				
		8/0				
ADJUSTABLE HINGE	UNDERSIZE	6/6	9.400	38.650	67.900	N/A
		6/8				
		7/0				
		8/0				

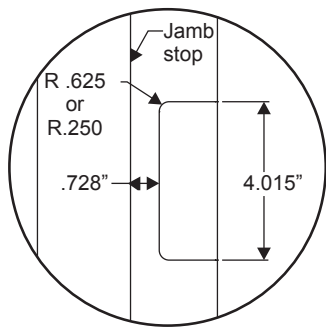
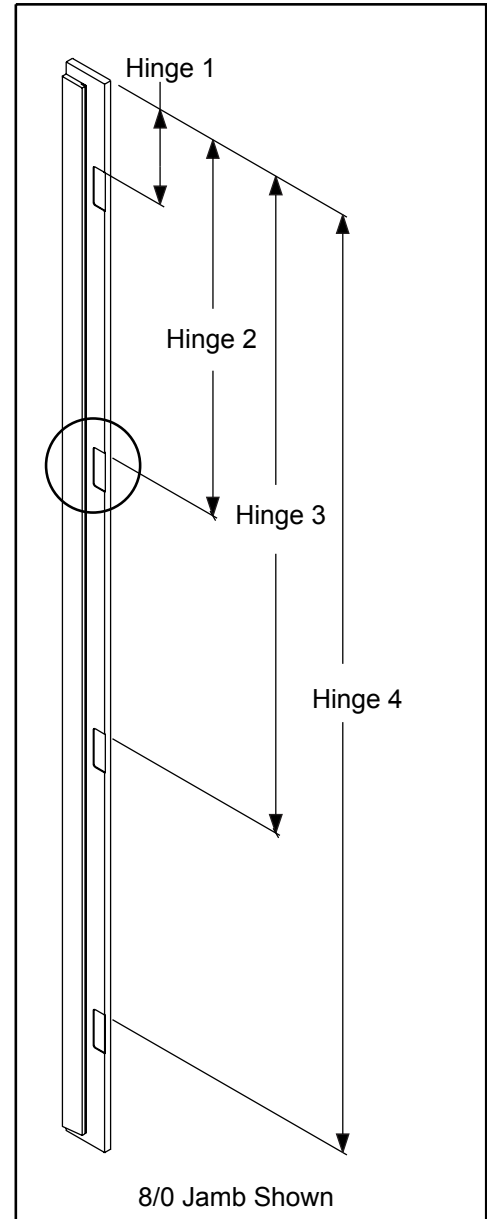

Standard Hinge

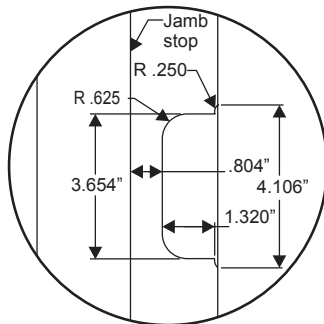
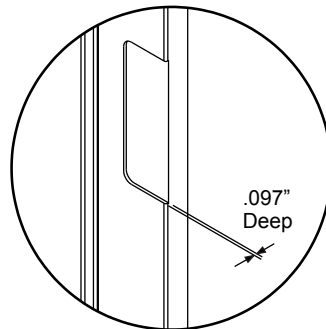

Adjustable Hinge

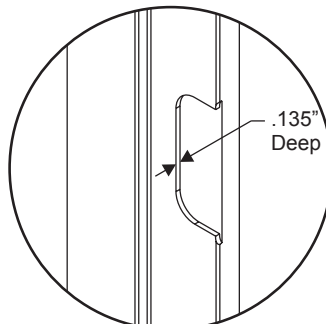

Frame Parts

	HINGE MORTISE LOCATIONS					
	UNIT HEIGHT	UNIT WIDTH	HINGE 1	HINGE 2	HINGE 3	HINGE 4
ARCH	6/8	3/0 or 3/6	9.860	37.297	64.735	N/A
	8/0		10.985	34.235	57.485	80.735
RADIUS	6/8	3/0	9.860	32.985	56.110	N/A
		3/6	8.860	30.985	53.110	
	8/0	3/0	10.985	31.360	51.735	72.110
		3/6		30.260	49.735	69.110

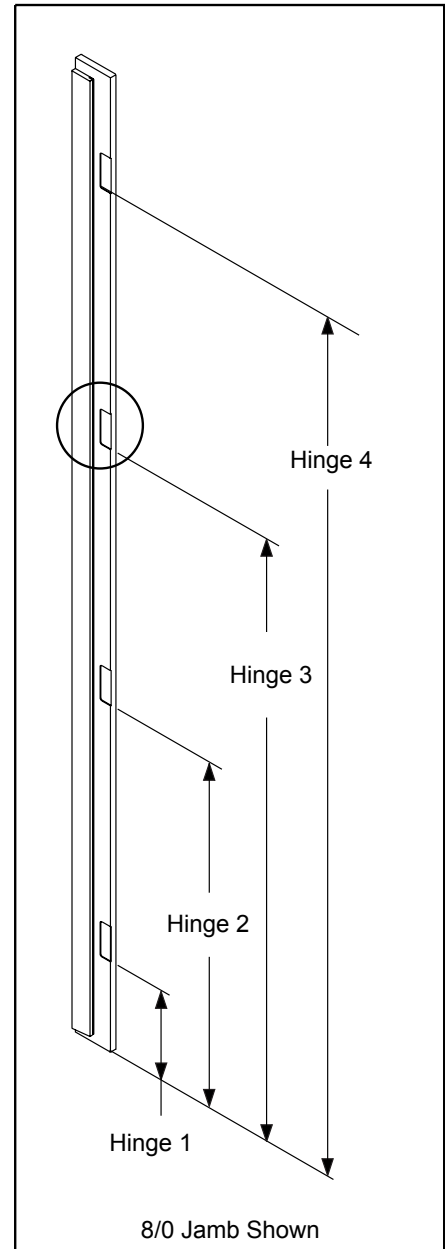
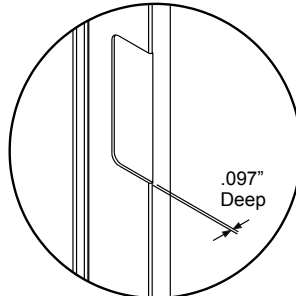
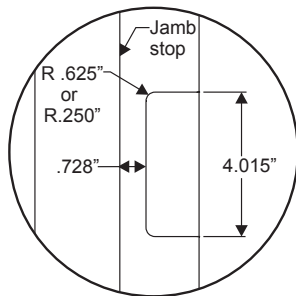

Frame Parts

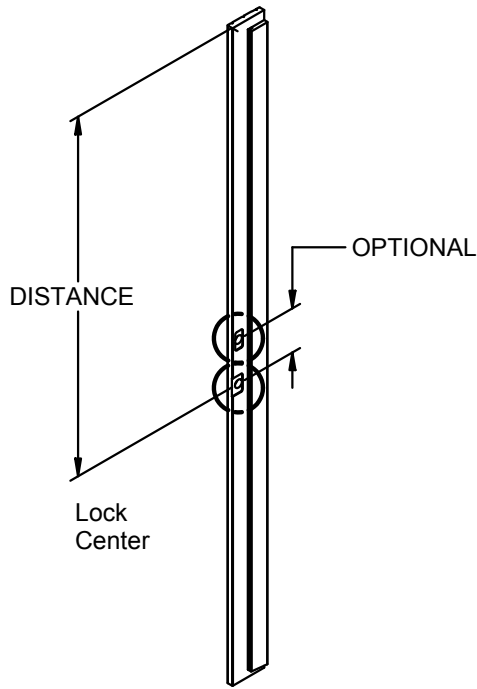

STANDARD SIDE JAMBS	
UNIT SIZE	STRIKE
6/6	44.844
6/8	
7/0	48.844
8/0	60.844

ARCH & RADIUS SIDE JAMBS			
	UNIT HEIGHT	UNIT WIDTH	STRIKE
ARCH	6/8	3/0	39.167
		3/6	39.401
	8/0	3/0	55.167
		3/6	55.401
RADIUS	6/8	3/0	25.108
		3/6	22.110
	8/0	3/0	41.108
		3/6	38.110

Frame Parts

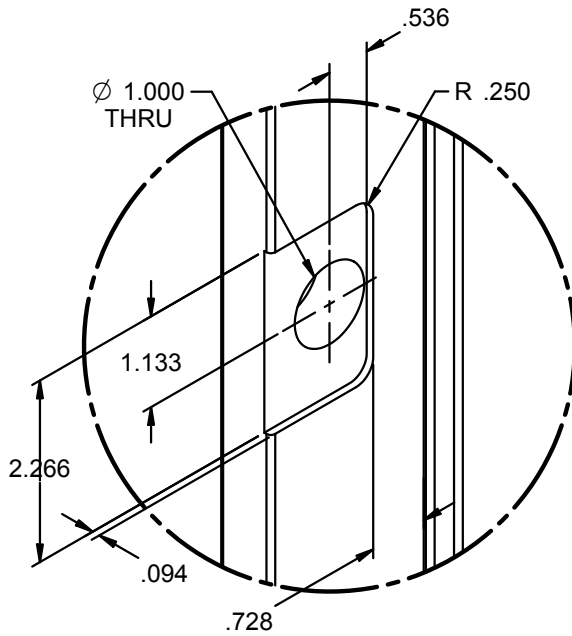

LATCH MACHINING

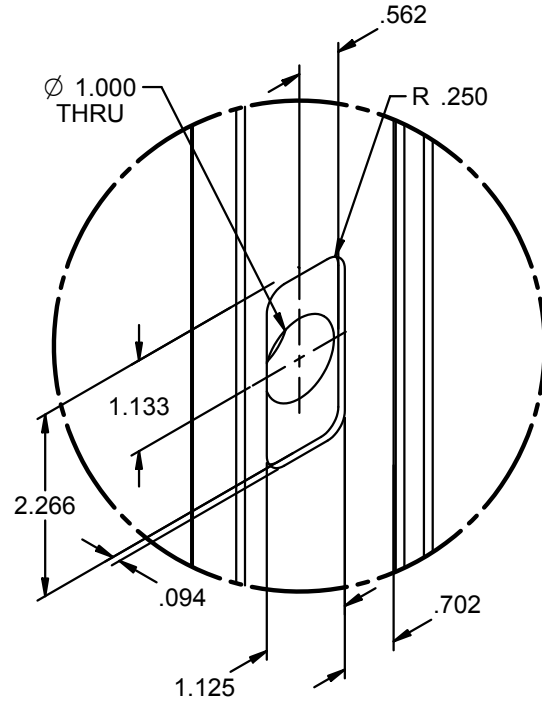

OPTIONAL DEADBOLT MACHINING

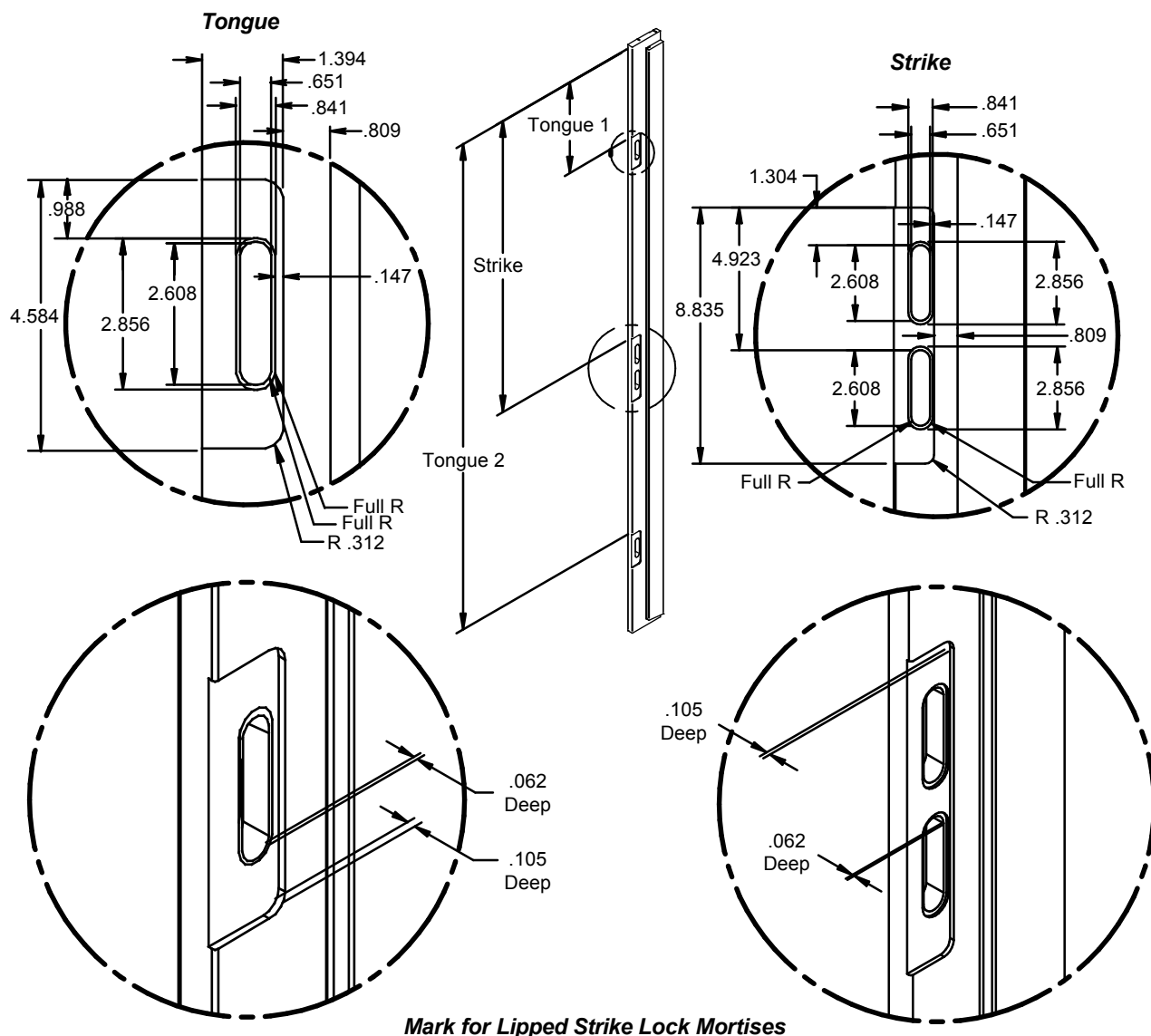

Frame Parts

**Manual Lipped Strike - Side Jamb
Lock Mortise Locations**

	UNIT SIZE	STRIKE	TONGUE 1	TONGUE 2
LIPPED STRIKE MACHINING	6/6	40.851	12.614	68.283
	6/8	40.851	12.614	68.283
	7/0	44.851	16.614	72.283
	8/0	56.851	10.896	84.283

Side Jambs

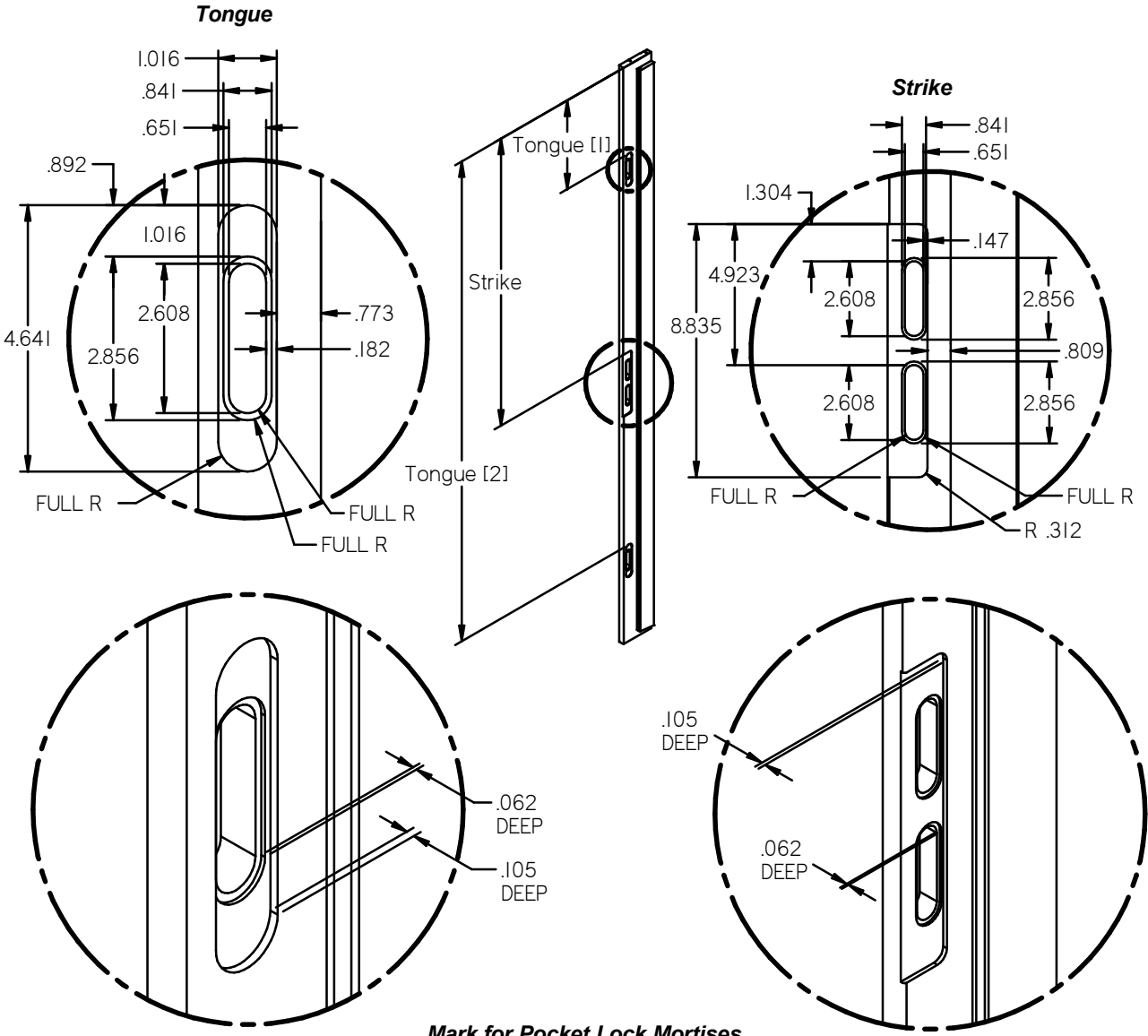

Frame Parts

Manual Pocket - Side Jamb
Lock Mortise Locations

		UNIT SIZE	STRIKE	TONGUE 1	TONGUE 2
POCKET STRIKE (MACHINING CODE P)	STANDARD	6/6	40.851	12.585	68.254
		6/8	40.851	12.585	68.254
		7/0	44.851	16.585	72.254
		8/0	56.851	10.867	84.254

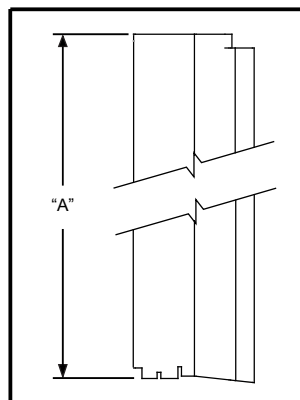
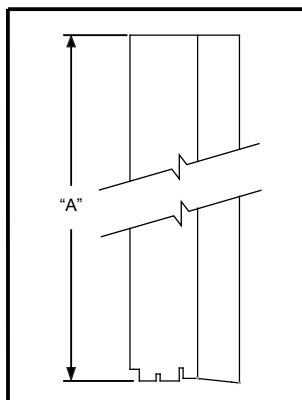

ENTRY MULLION		
	UNIT SIZE	LENGTH "A"
INSWING	6/6	77.680
	6/8	80.234
	7/0	84.234
	8/0	96.234
OUTSWING	6/6	USE PATIO MULLION
	6/8	
	7/0	
	8/0	

PATIO MULLION		
	UNIT SIZE	LENGTH "A"
INSWING	6/6	77.686
	6/8	80.234
	7/0	84.234
	8/0	96.234
OUTSWING	6/6	77.128
	6/8	79.676
	7/0	83.676
	8/0	95.676

Frame Parts

Mullions

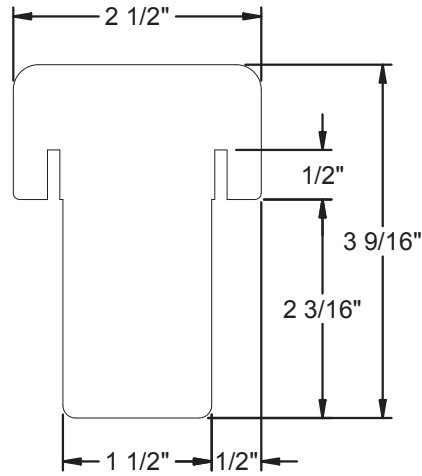
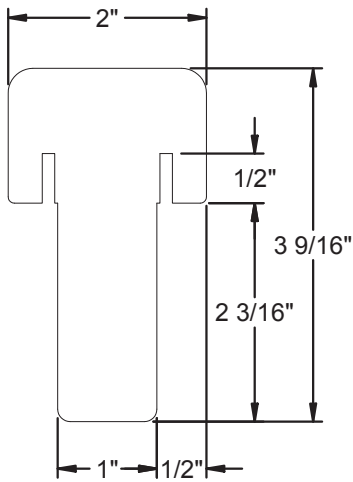

**Oak, Pine, and Rot-Resistant
Standard & Wide Mullion**

Frame Parts

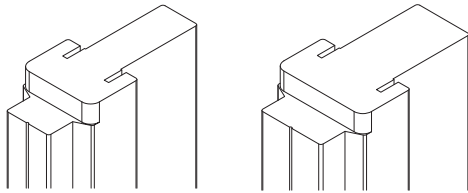

Patio Standard & Wide Mullion
(Must be used with all screen applications)

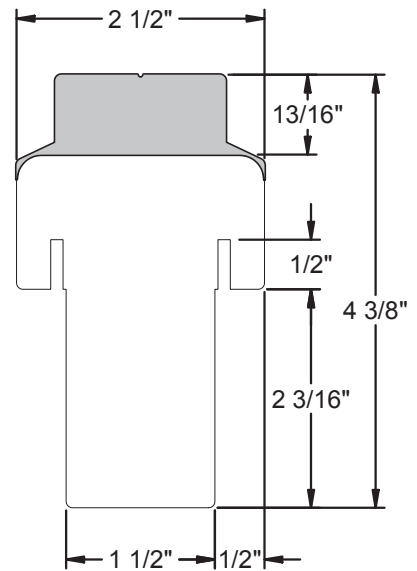
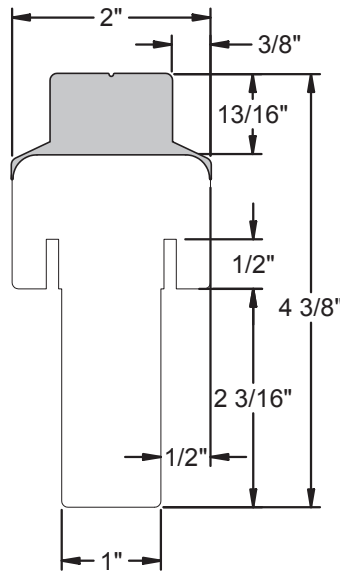

Sill End Details

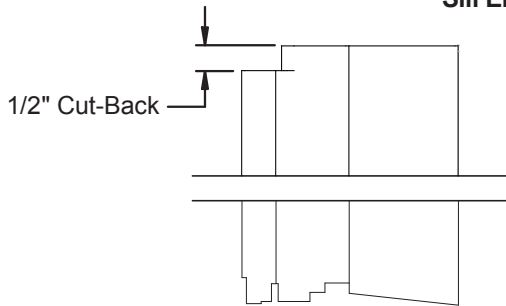

Composite Outswing
(Patio Mullion Must Be Used)

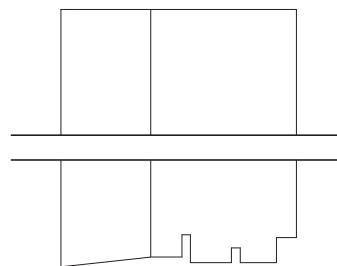

**Composite/Hardwood
Inswing Adjustable**
(Entry Mullion Shown)

Hinge Mortise Locations

		HINGE MORTISE LOCATIONS				
		UNIT SIZE	HINGE [1]	HINGE [2]	HINGE [3]	HINGE [4]
STANDARD HINGE	UNDERSIZE	6/6	8.375	38.125	67.875	N/A
		6/8				N/A
		7/0		40.125	71.875	N/A
		8/0		33.375	58.875	83.875
ADJUSTABLE HINGE	UNDERSIZE	6/6	8.650	37.900	67.150	N/A
		6/8				
		7/0	5.556	31.056	56.556	82.056
		8/0				

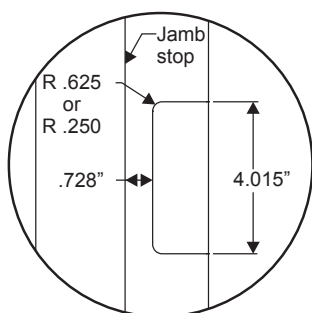

Standard Hinge

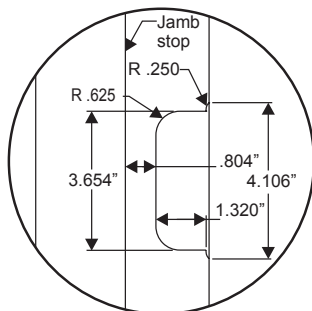
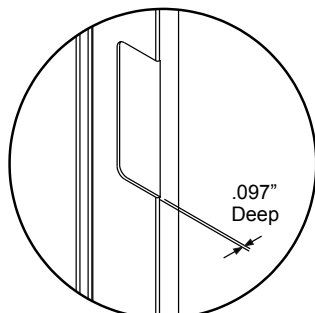

Adjustable Hinge

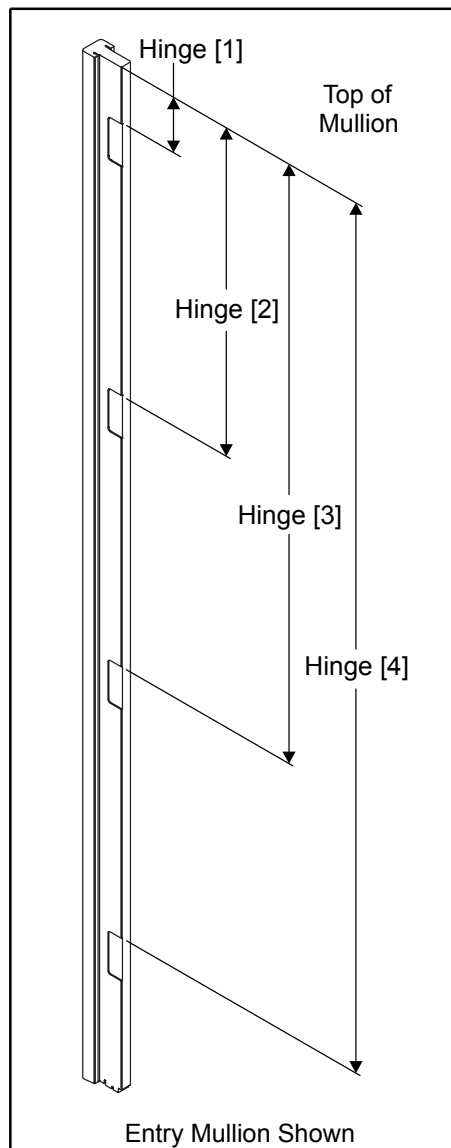
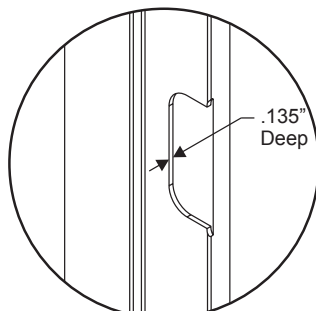

Frame Parts

Standard Lock Mortise location

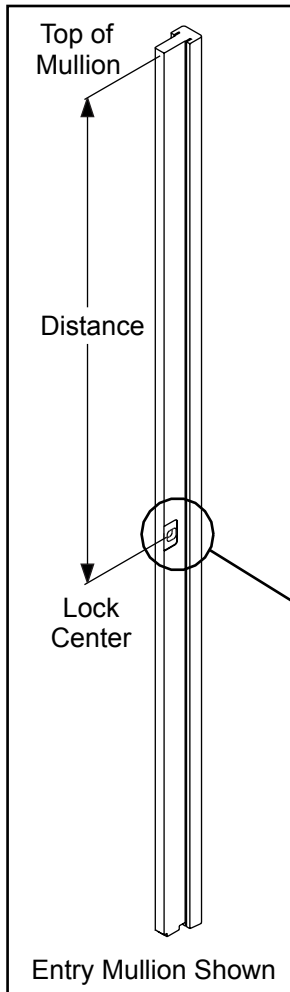

UNIT SIZE	STRIKE
6/6	44.094
6/8	
7/0	48.094
8/0	60.094

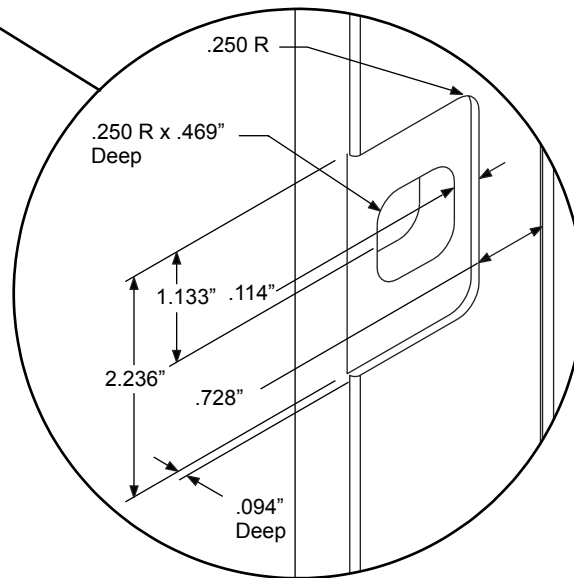

Frame Parts

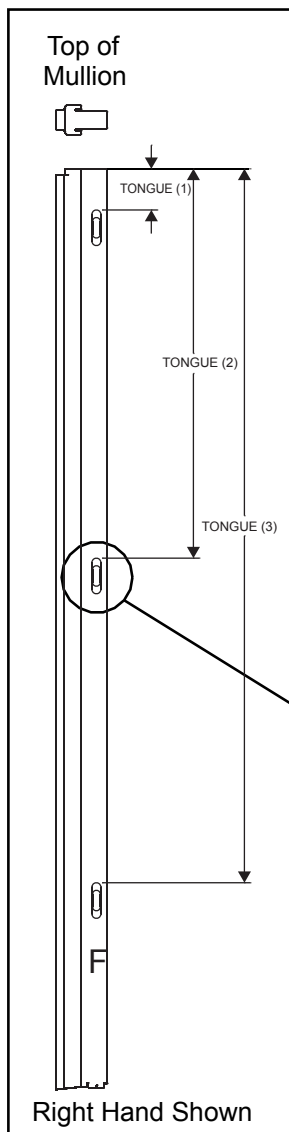

**Vented Sidelite Lock
Mortise Location**

VENTING SIDELITE MPLS				
	UNIT SIZE	TONGUE 1	TONGUE 2	TONGUE 3
STANDARD	6/6	3.489	32.989	60.491
	6/8			
	8/0	16.489	48.989	76.491

Frame Parts

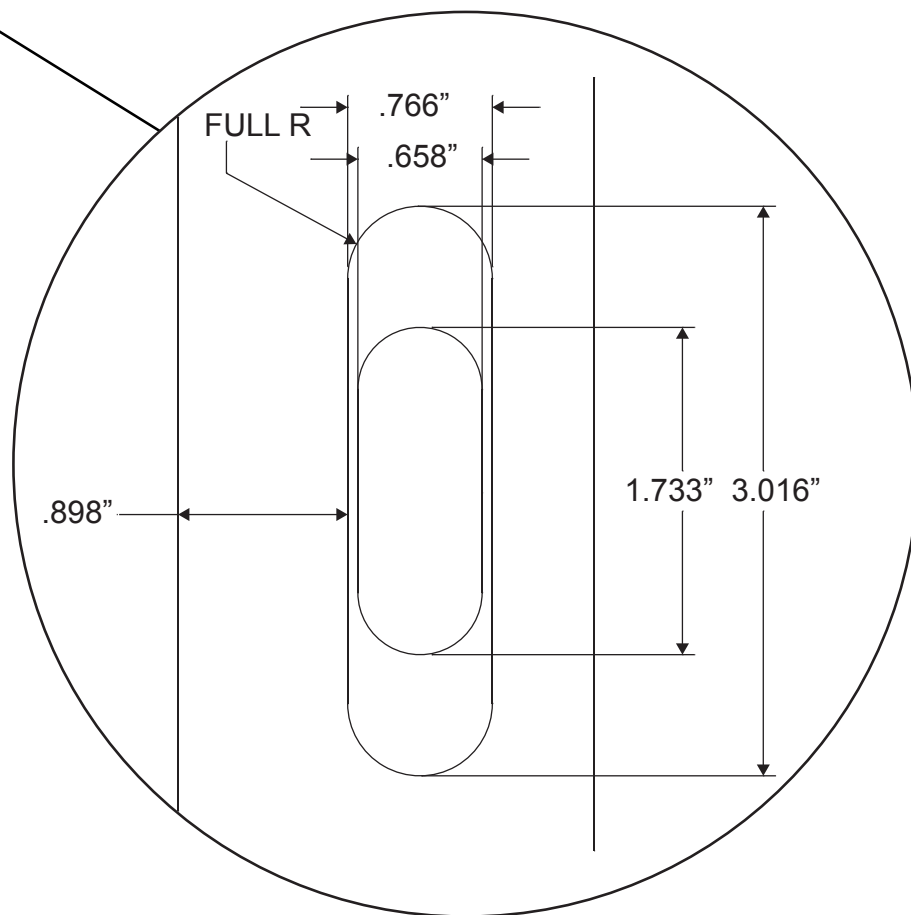

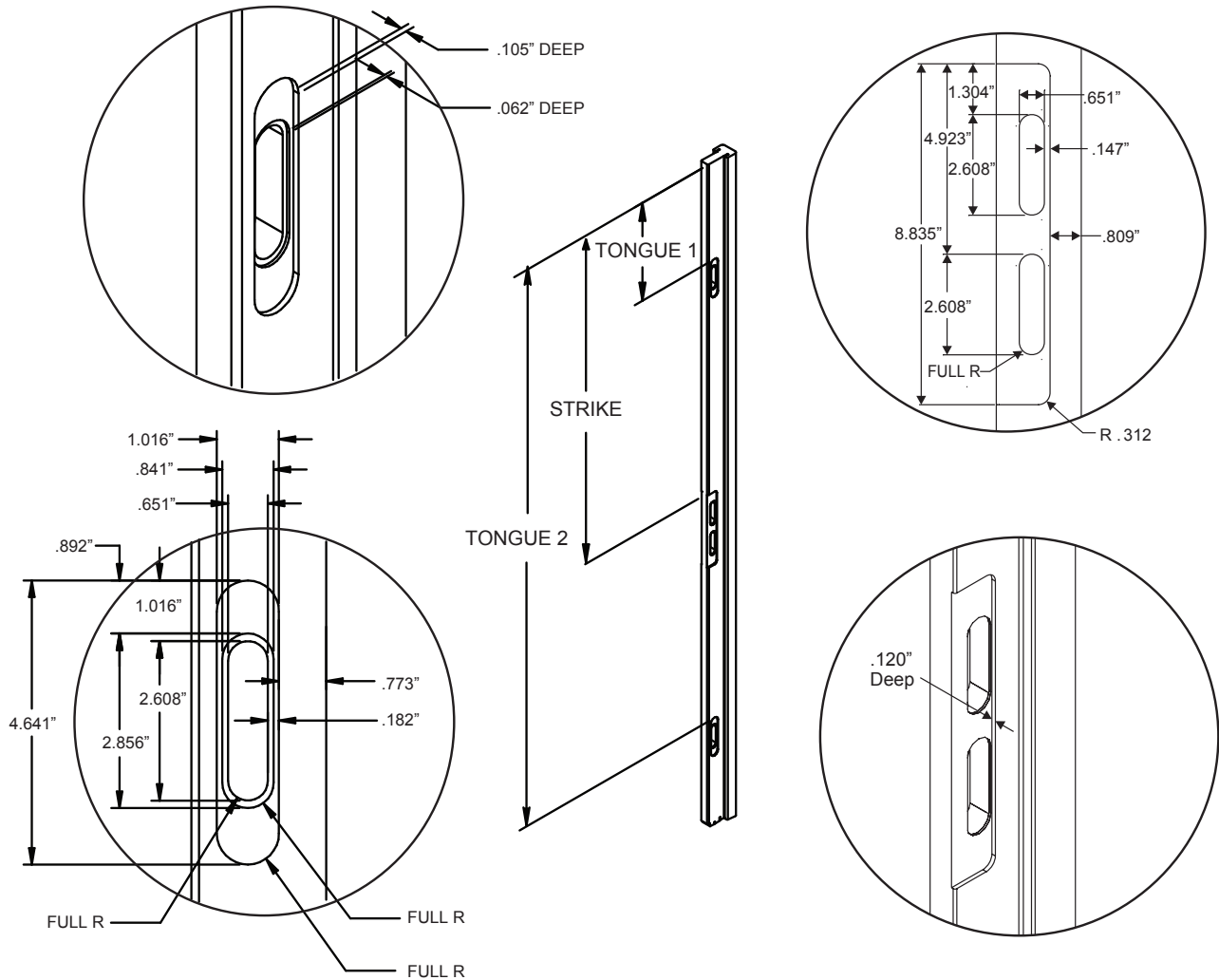

Frame Parts

Manual Tongue & Variable Height Lock Mortise Location

	UNIT SIZE	STRIKE	TONGUE 1	TONGUE 2
POCKET STRIKE	6/6	40.101	11.836	67.506
	6/8	40.101	11.836	67.506
	7/0	44.101	15.836	71.506
	8/0	56.101	10.188	83.506

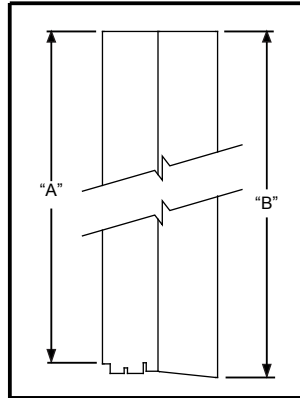

		SPREAD MULLION JAMB				
		UNIT SIZE	LENGTH "A"	"B"		
				4-9/16"	5-1/4"	6-9/16"
INSWING	UNDERSIZE	66 = 6/6	77.291	77.834	77.906	78.044
		68 = 6/8	79.839	80.382	80.454	80.592
		70 = 7/0	83.839	84.382	84.454	84.592
		80 = 8/0	95.839	96.382	96.454	96.592
	SILL/SILL GAIN	68 = 6/8	80.292	81.378	81.450	81.588
		80 = 8/0	96.292	97.378	97.450	97.588

Frame Parts

Spread Mullion Jambs

SPREAD MULLION HINGE MORTISE LOCATIONS					
	UNIT SIZE	HINGE [1]	HINGE [2]	HINGE [3]	HINGE [4]
STANDARD HINGE	6/6	8.375	38.125	67.875	N/A
	6/8				
	7/0				
	8/0				
ADJUSTABLE HINGE	6/6	8.650	37.900	67.150	N/A
	6/8				
	7/0				
	8/0		5.556	31.056	

Frame Parts

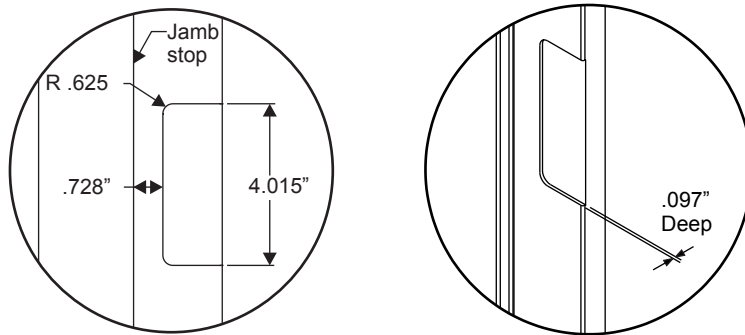

Standard Hinge

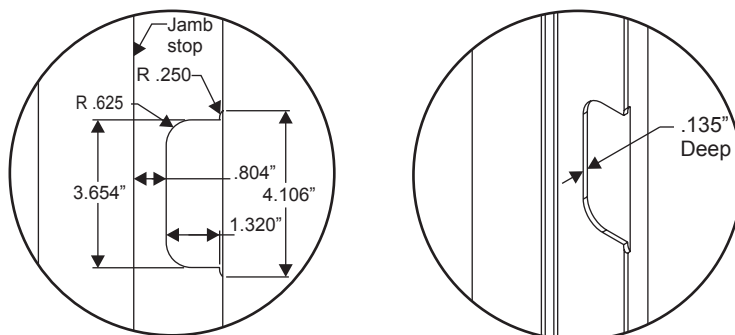

Adjustable Hinge

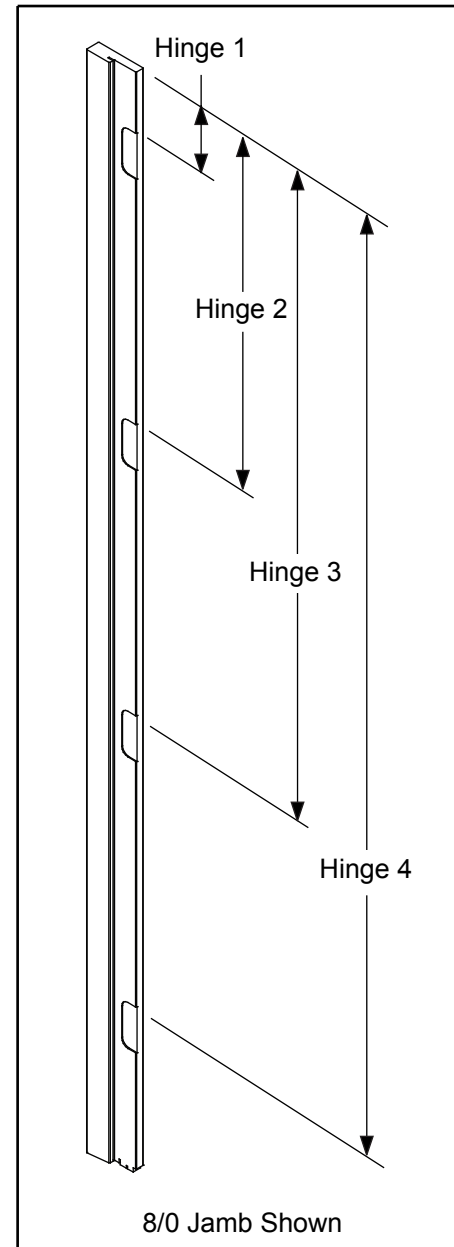

8/0 Jamb Shown

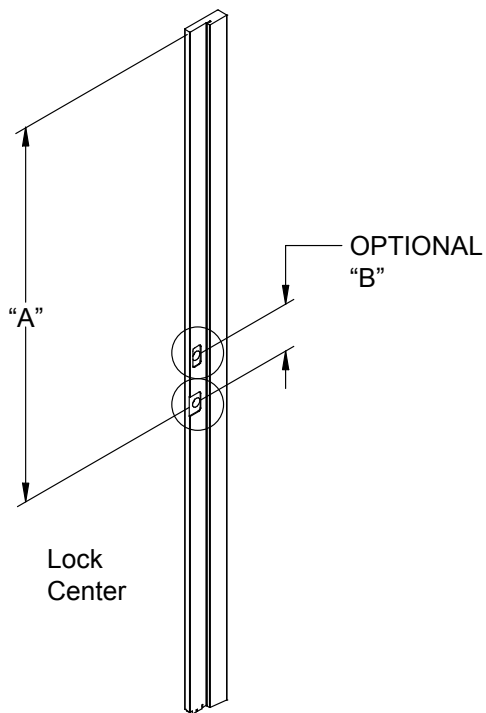

UNIT SIZE	"A"
6/6	44.094
6/8	
7/0	48.094
8/0	60.094

DOUBLE BORE CENTER TO CENTER	
CODE	"B"
J	N/A
K	12.000
L	5.500

Frame Parts

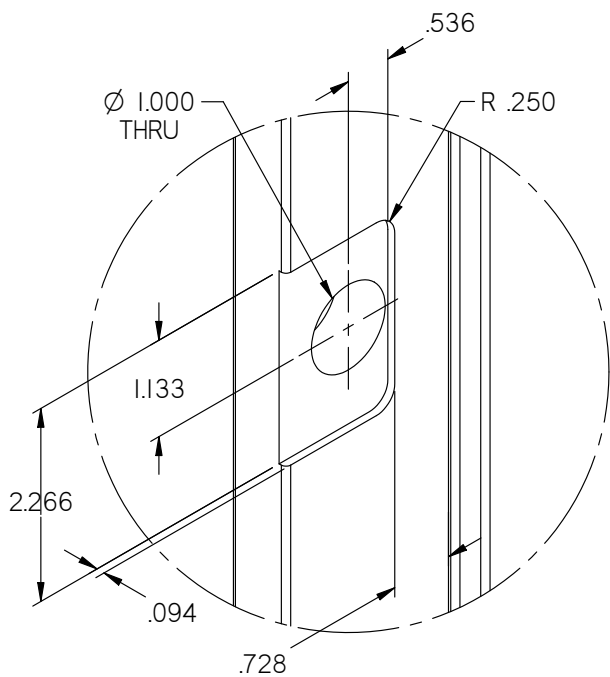

LATCH MACHINING

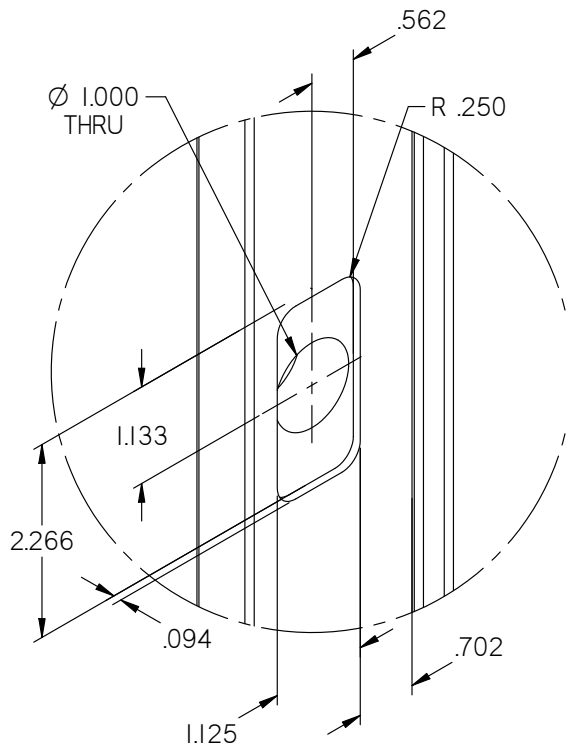

OPTIONAL DEADBOLT MACHINING

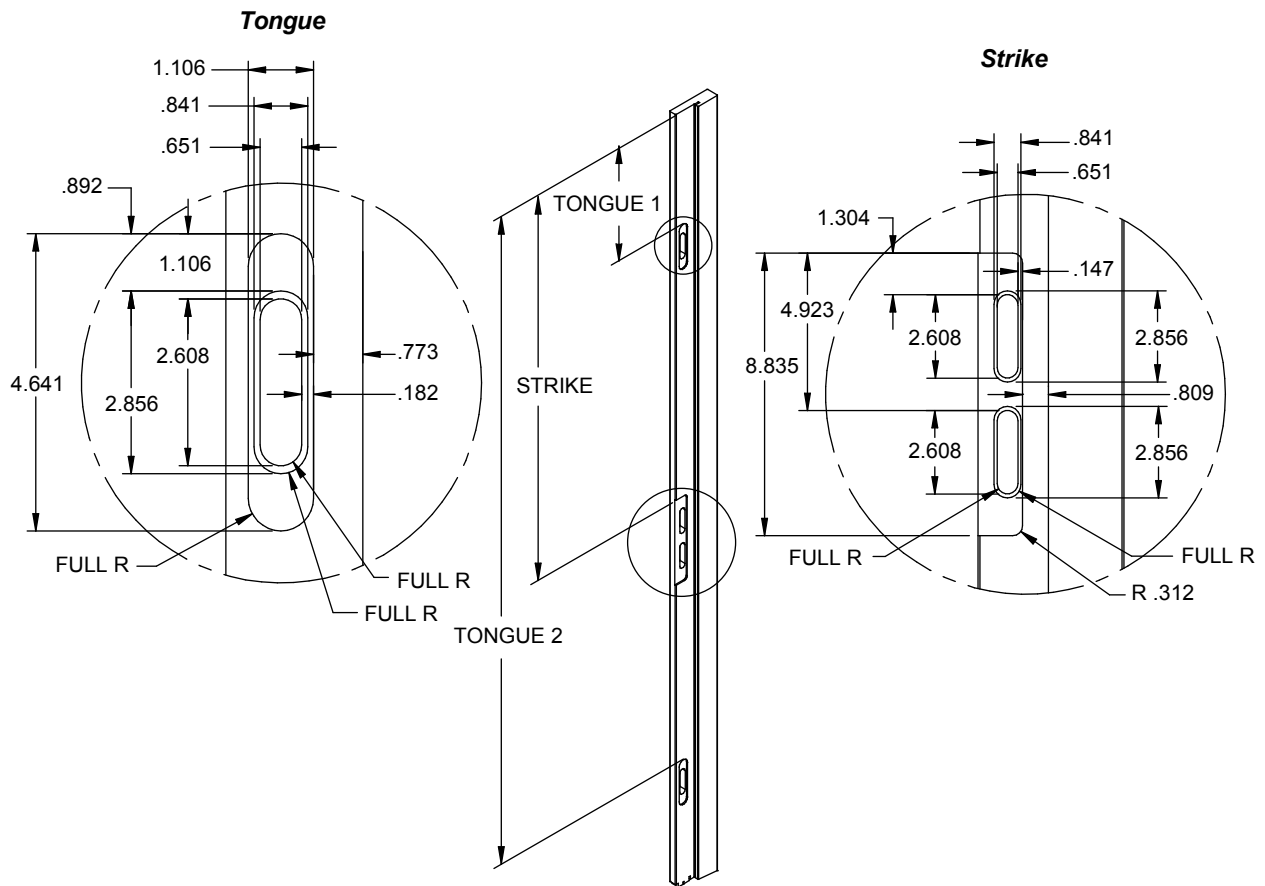

Frame Parts

Mark for Pocket Lock Mortises

**Manual Pocket - Side Jamb
Lock Mortise Locations
Spread Mullions**

	UNIT SIZE	STRIKE	TONGUE 1	TONGUE 2
POCKET STRIKE	6/6	40.101	11.835	67.504
	6/8	40.101	11.835	67.504
	7/0	44.101	15.835	71.504
	8/0	56.101	10.177	83.504

Standard Lock

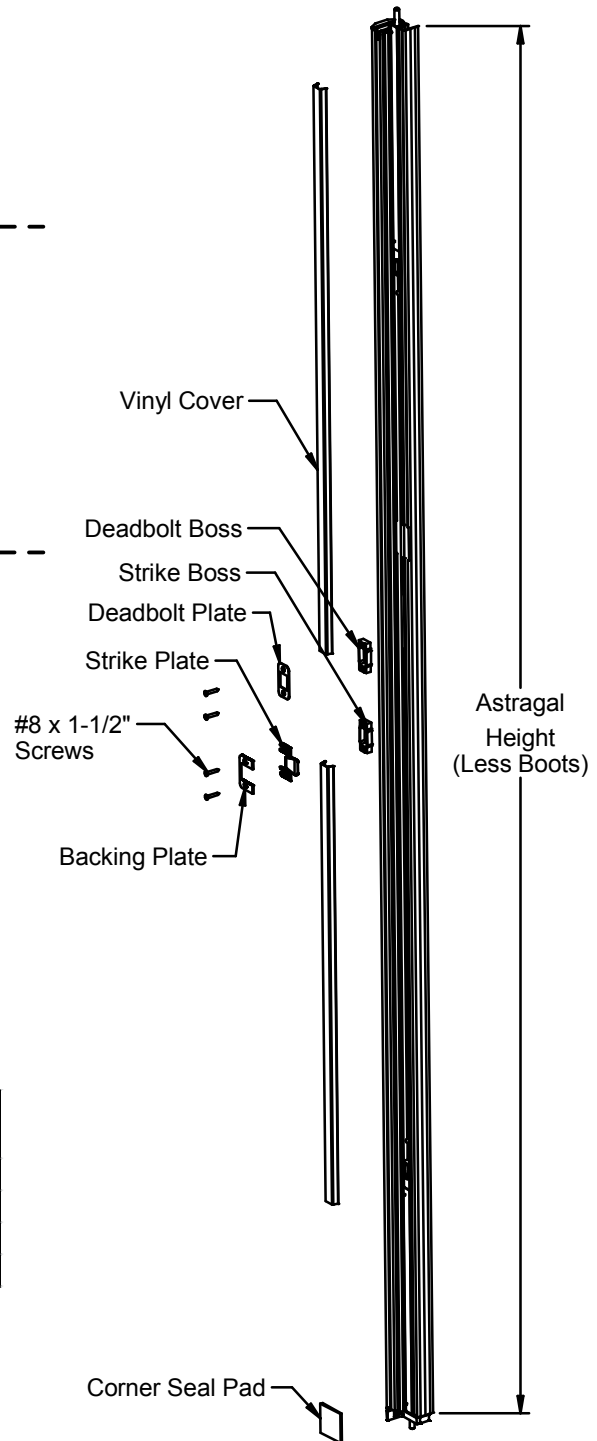
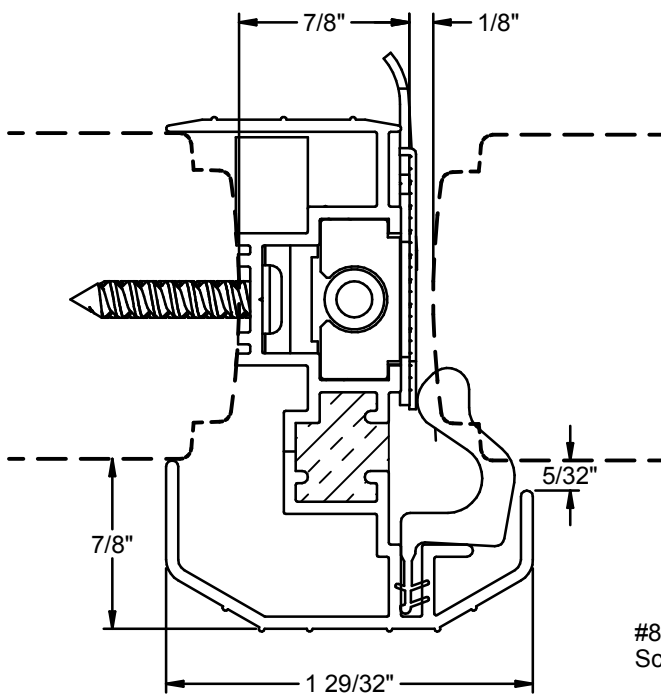

Frame Parts

DOOR HEIGHT	INSWING ASTRAGAL OVERALL HEIGHT	OUTSWING ASTRAGAL OVERALL HEIGHT
6/6	76.702	76.702
6/8	79.250	79.250
7/0	83.250	83.250
8/0	95.250	95.250

Astragals come complete with the necessary hardware. See Hardware section.

Multi-Point Lock Manual Shootbolt

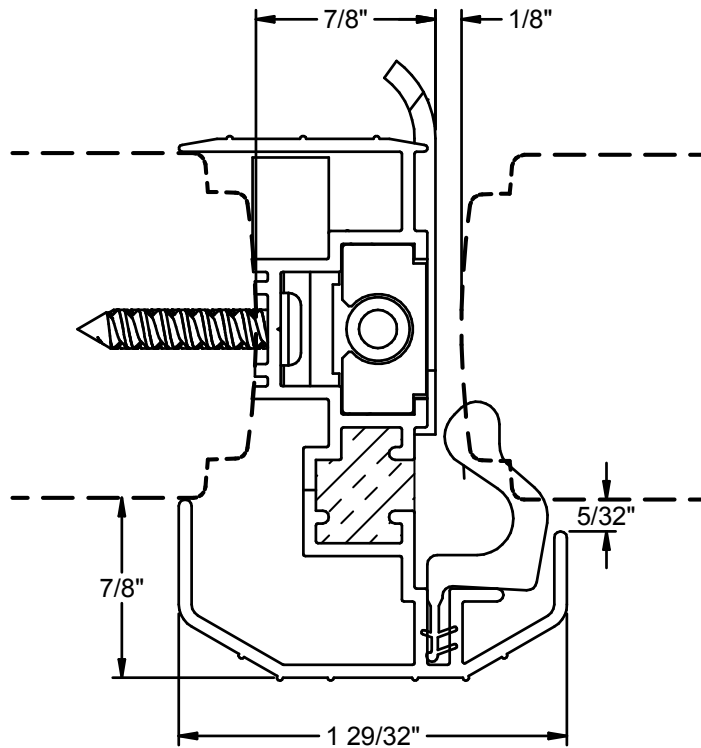

Frame Parts

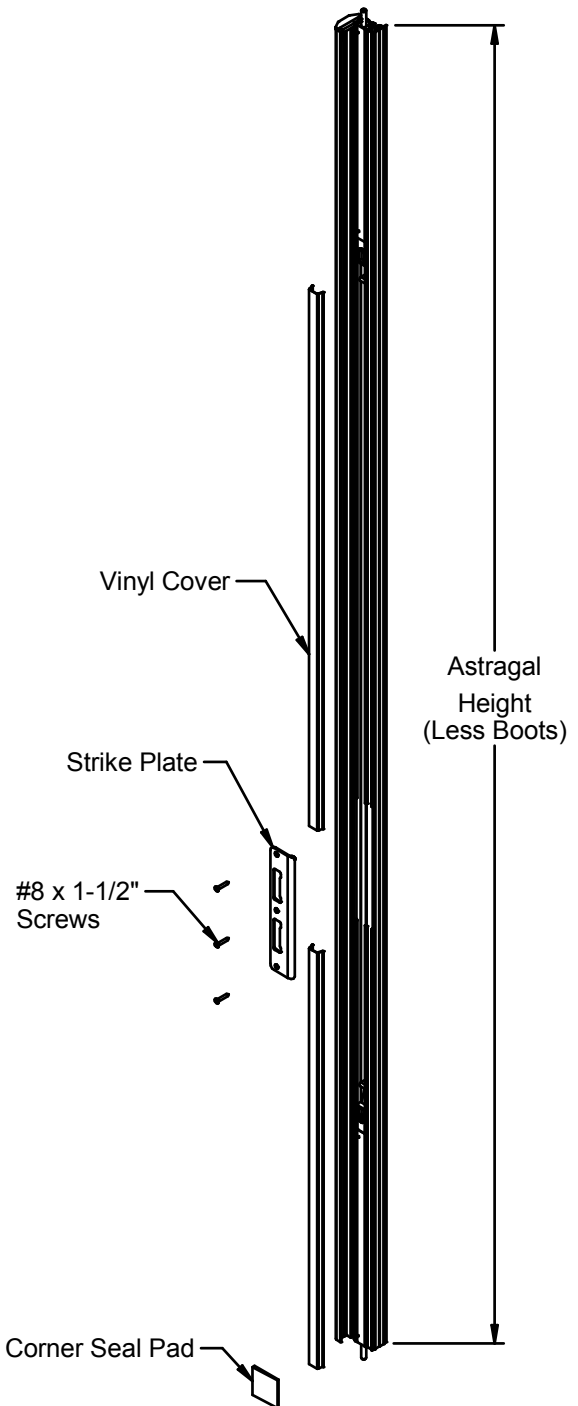

DOOR HEIGHT	INSWING ASTRAGAL OVERALL HEIGHT	OUTSWING ASTRAGAL OVERALL HEIGHT
6/6	76.702	76.702
6/8	79.250	79.250
7/0	83.250	83.250
8/0	95.250	95.250

Astragals come complete with the necessary hardware.
See Hardware section.

Standard Lock

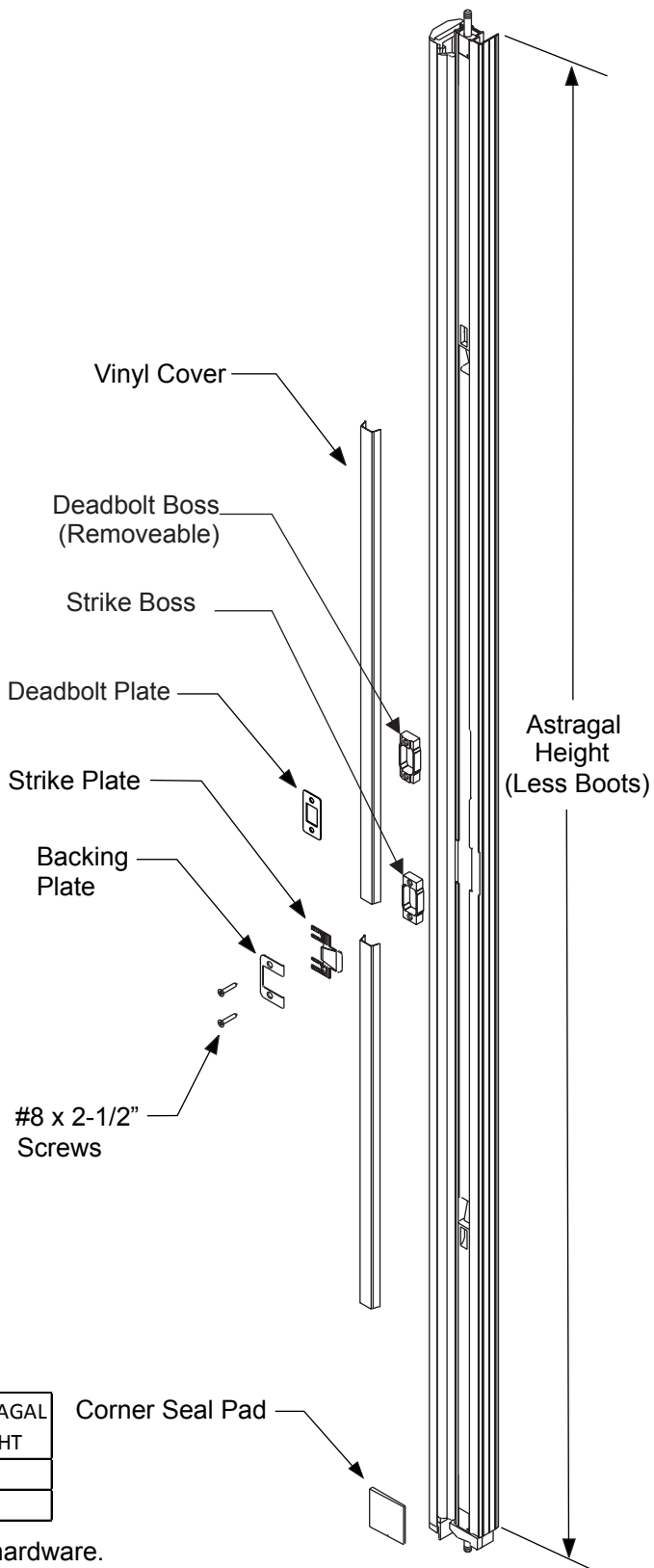
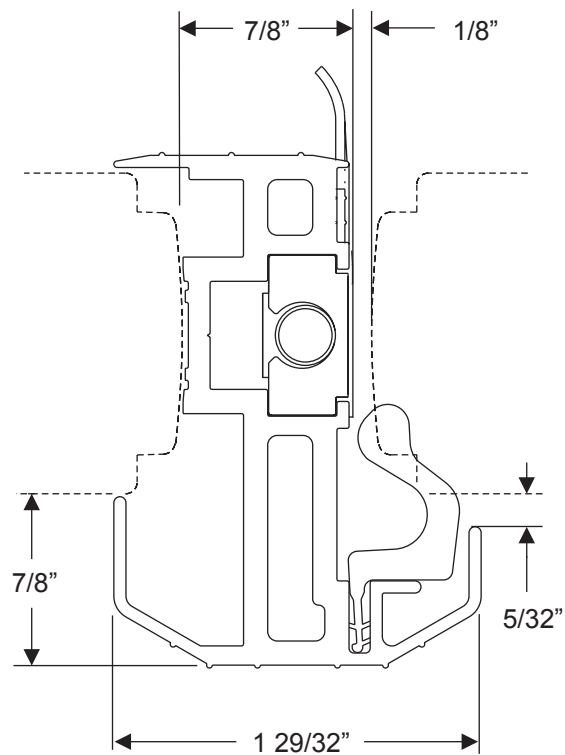

Frame Parts

DOOR HEIGHT	INSWING ASTRAGAL OVERALL HEIGHT	OUTSWING ASTRAGAL OVERALL HEIGHT
6/8	79.250	79.250
8/0	95.250	95.250

Astragals come complete with the necessary hardware. See Hardware section.

Multi-Point Lock Manual Shootbolt

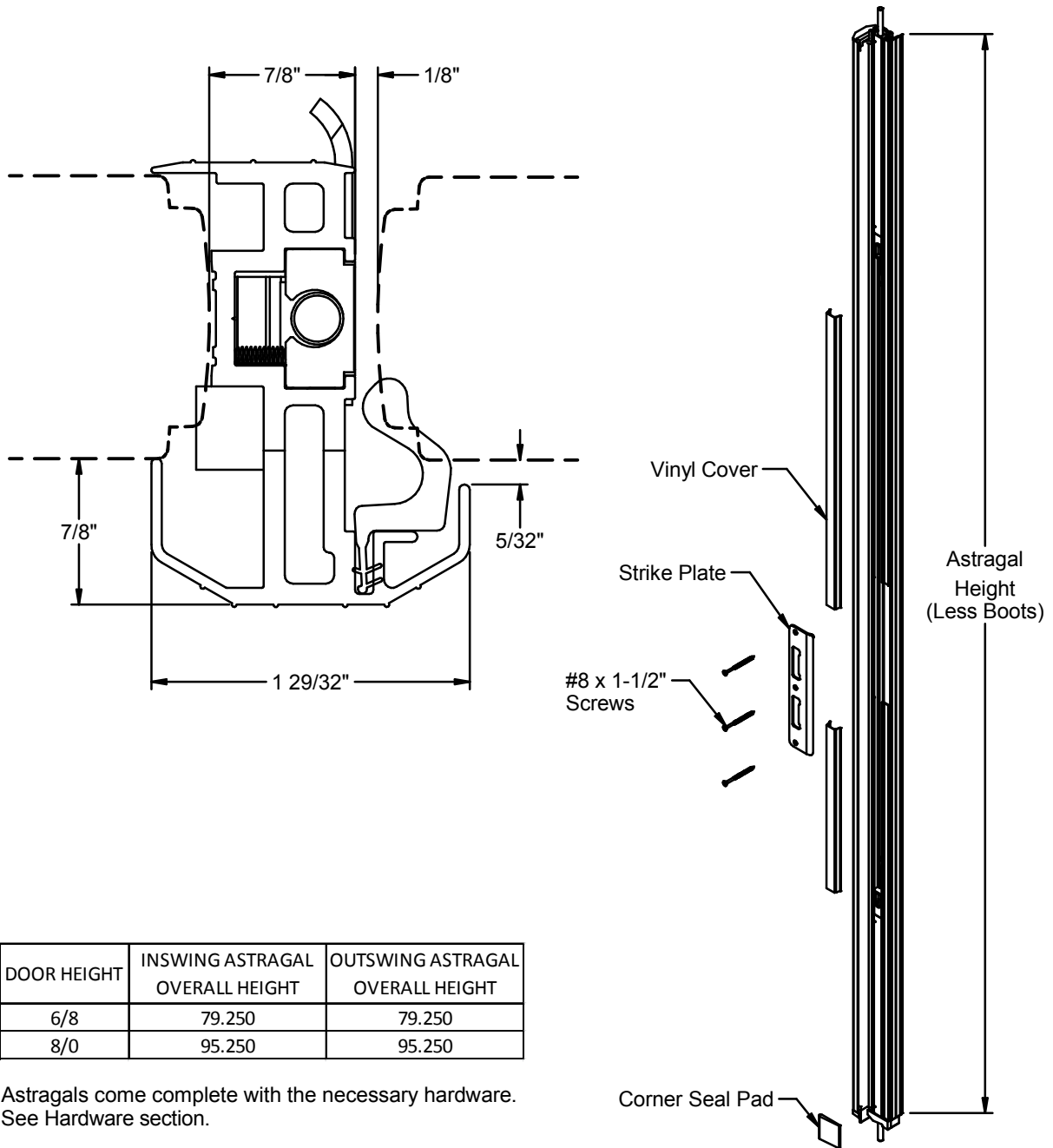

Frame Parts

DOOR HEIGHT	INSWING ASTRAGAL OVERALL HEIGHT	OUTSWING ASTRAGAL OVERALL HEIGHT
6/8	79.250	79.250
8/0	95.250	95.250

Astragals come complete with the necessary hardware. See Hardware section.

**7/8" Aluminum Outswing
Astragal Security Cover**

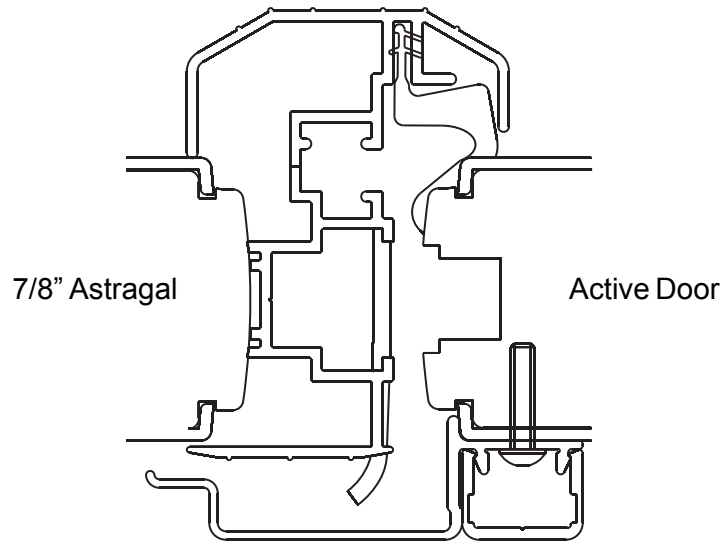

Frame Parts

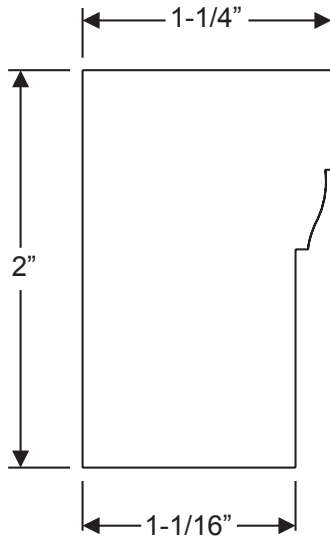

***Brickmould - Wood and Rot-Resistant
(WM180 Profile)***

Frame Parts

Head Length

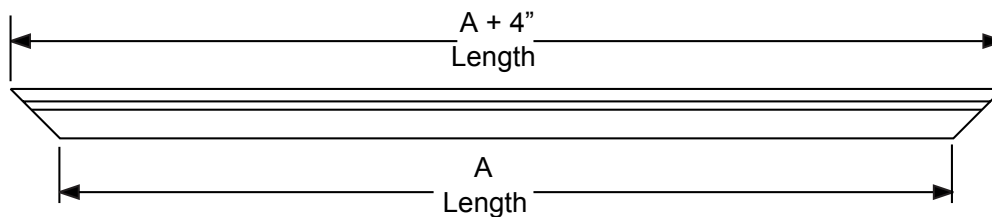

			UNIT SIZE	INSWING "A"	OUTSWING "A"
SINGLE		STANDARD LENGTHS	2/4	28.000	28.500
			2/6	30.000	30.500
			2/8	32.000	32.500
			2/10	34.000	34.500
			3/0	36.000	36.500
			3/6	42.000	42.500
FRENCH (7/8" ASTRAGAL)		STANDARD LENGTHS	4/0	48.718	49.218
			4/8	56.718	57.218
			5/0	60.718	61.218
			5/4	64.718	65.218
			5/8	68.718	69.218
			6/0	72.718	73.218
DOUBLE	STANDARD MULLION	STANDARD LENGTHS	4/8	57.000	57.500
			5/0	61.000	61.500
			5/4	65.000	65.500
			5/8	69.000	69.500
			6/0	73.000	73.500
			6/0	73.000	73.500
DOUBLE PLUS M.E.U.	STANDARD MULLION	STANDARD LENGTHS	4/8 + 2/4	86.500	87.000
			5/0 + 2/6	92.500	93.000
			5/4 + 2/8	98.500	99.000
			5/8 + 2/10	104.500	105.000
			6/0 + 3/0	110.500	111.000
			6/0 + 3/0	110.500	111.000
TRIPLE	STANDARD MULLION	STANDARD LENGTHS	7/0	86.000	86.500
			7/6	92.000	92.500
			8/0	98.000	98.500
			8/6	104.000	104.500
			9/0	110.000	110.500
			9/0	110.000	110.500

			UNIT SIZE	INSWING "A"	OUTSWING "A"
SINGLE WITH 1 VENTING SIDELITE	STANDARD MULLION	STANDARD LENGTHS	2/4 W/1-12"	41.721	N/A
			2/4 W/1-14"	43.721	N/A
			2/6 W/1-12"	43.721	N/A
			2/6 W/1-14"	45.721	N/A
			2/8 W/1-12"	45.721	N/A
			2/8 W/1-14"	47.721	N/A
			2/10 W/1-12"	47.721	N/A
			2/10 W/1-14"	49.721	N/A
			3/0 W/1-12"	49.721	N/A
			3/0 W/1-14"	51.721	N/A
SINGLE UNIT WITH TWO VENTING SIDELITES	WIDE MULLION	STANDARD LENGTHS	2/4 W/1-12"	55.408	N/A
			2/4 W/1-14"	59.408	N/A
			2/6 W/1-12"	57.408	N/A
			2/6 W/1-14"	61.408	N/A
			2/8 W/1-12"	59.408	N/A
			2/8 W/1-14"	63.408	N/A
			2/10 W/1-12"	61.408	N/A
			2/10 W/1-14"	65.408	N/A
FRENCH (7/8" ASTRAGAL) UNIT WITH VENTING SIDELITES	WIDE MULLION	STANDARD LENGTHS	4/8 W/2-12"	84.126	N/A
			4/8 W/2-14"	88.126	N/A
			5/0 W/2-12"	88.126	N/A
			5/4 W/2-12"	92.126	N/A
			5/4 W/2-14"	96.126	N/A
			5/8 W/2-12"	96.126	N/A
5/8 W/2-14"	100.126	N/A			
6/0 W/2-12"	100.126	N/A			
6/0 W/2-14"	104.126	N/A			

Frame Parts

Head Length

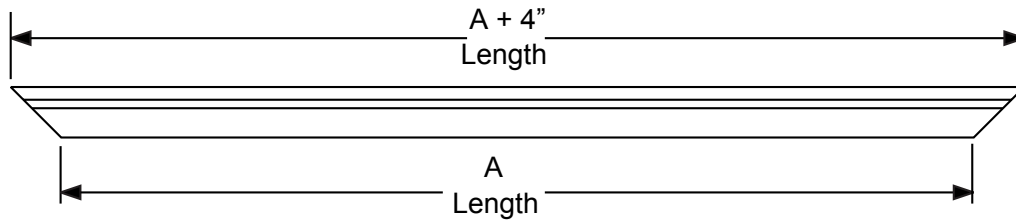

			UNIT SIZE	INSWING "A"	OUTSWING "A"
SINGLE WITH 1 SIDELITE	STANDARD MULLION	STANDARD	2/4 W/1 12"	41.000	41.500
			2/4 W/1 14"	43.000	43.500
			2/6 W/1 12"	43.000	43.500
			2/6 W/1 14"	45.000	45.500
			2/8 W/1 12"	45.000	45.500
			2/8 W/1 14"	47.000	47.500
			2/10 W/1 12"	47.000	47.500
			2/10 W/1 14"	49.000	49.500
			3/0 W/1 12"	49.000	49.500
			3/0 W/1 14"	51.000	51.500
			3/6 W/1 12"	55.000	55.500
			3/6 W/1 14"	57.000	57.500
	BOXED/WIDE MULLION	STANDARD	2/4 W/1 12"	41.500	42.000
			2/4 W/1 14"	43.500	44.000
			2/6 W/1 12"	43.500	44.000
			2/6 W/1 14"	45.500	46.000
			2/8 W/1 12"	45.500	46.000
			2/8 W/1 14"	47.500	48.000
			2/10 W/1 12"	47.500	48.000
			2/10 W/1 14"	49.500	50.000
			3/0 W/1 12"	49.500	50.000
			3/0 W/1 14"	51.500	52.000
SINGLE WITH 2 SIDELITES	STANDARD MULLION	STANDARD	2/4 W/2 12"	54.000	54.500
			2/4 W/2 14"	58.000	58.500
			2/6 W/2 12"	56.000	56.500
			2/6 W/2 14"	60.000	60.500
			2/8 W/2 12"	58.000	58.500
			2/8 W/2 14"	62.000	62.500
			2/10 W/2 12"	60.000	60.500
			2/10 W/2 14"	64.000	64.500
			3/0 W/2 12"	62.000	62.500
			3/0 W/2 14"	66.000	66.500
	STANDARD MULLION	STANDARD	2/4 W/1 12"	55.000	55.500
			2/4 W/1 14"	59.000	59.500
			2/6 W/1 12"	57.000	57.500
			2/6 W/1 14"	61.000	61.500
			2/8 W/1 12"	59.000	59.500
			2/8 W/1 14"	63.000	63.500
			2/10 W/1 12"	61.000	61.500
			2/10 W/1 14"	65.000	65.500
			3/0 W/1 12"	63.000	63.500
			3/0 W/1 14"	67.000	67.500
3/6 W/1 12"	69.000	69.500			

			UNIT SIZE	INSWING "A"	OUTSWING "A"
FRENCH WITH 2 SIDELITES (7/8" ASTRAGAL)	WIDE MULLION	STANDARD LENGTHS	6/0 W/2-10"	95.718	96.218
			6/0 W/2-12"	99.718	100.218
			6/0 W/2-14"	103.718	104.218

Frame Parts

Head Length

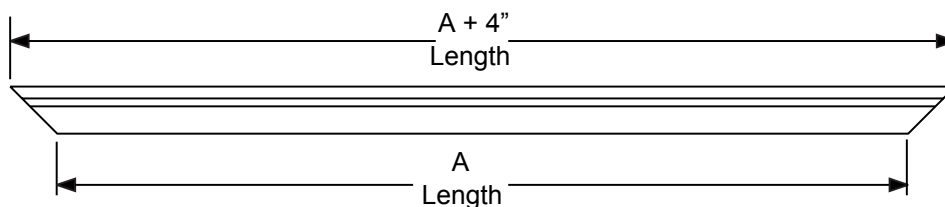

	UNIT SIZE	INSWING
	"A"	
SINGLE WITH ONE SIDELITE	3/0 W/1 10" SPREAD 0.000"	47.500
	3/0 W/1 10" SPREAD 0.250"	47.750
	3/0 W/1 10" SPREAD 0.500"	48.000
	3/0 W/1 10" SPREAD 0.750"	48.250
	3/0 W/1 10" SPREAD 1.000"	48.500
	3/0 W/1 10" SPREAD 1.250"	48.750
	3/0 W/1 10" SPREAD 1.500"	49.000
	3/0 W/1 10" SPREAD 1.750"	49.250
	3/0 W/1 10" SPREAD 2.000"	49.500
	3/0 W/1 10" SPREAD 2.250"	49.750
	3/0 W/1 10" SPREAD 2.500"	50.000
	3/0 W/1 10" SPREAD 2.750"	50.250
	3/0 W/1 10" SPREAD 3.000"	50.500
	3/0 W/1 12" SPREAD 0.000"	49.500
	3/0 W/1 12" SPREAD 0.250"	49.750
	3/0 W/1 12" SPREAD 0.500"	50.000
	3/0 W/1 12" SPREAD 0.750"	50.250
	3/0 W/1 12" SPREAD 1.000"	50.500
	3/0 W/1 12" SPREAD 1.250"	50.750
	3/0 W/1 12" SPREAD 1.500"	51.000
	3/0 W/1 12" SPREAD 1.750"	51.250
	3/0 W/1 12" SPREAD 2.000"	51.500
	3/0 W/1 12" SPREAD 2.250"	51.750
	3/0 W/1 12" SPREAD 2.500"	52.000
	3/0 W/1 12" SPREAD 2.750"	52.250
	3/0 W/1 12" SPREAD 3.000"	52.500
	3/0 W/1 14" SPREAD 0.000"	51.500
	3/0 W/1 14" SPREAD 0.250"	51.750
	3/0 W/1 14" SPREAD 0.500"	52.000
	3/0 W/1 14" SPREAD 0.750"	52.250
	3/0 W/1 14" SPREAD 1.000"	52.500
	3/0 W/1 14" SPREAD 1.250"	52.750
3/0 W/1 14" SPREAD 1.500"	53.000	
3/0 W/1 14" SPREAD 1.750"	53.250	
3/0 W/1 14" SPREAD 2.000"	53.500	
3/0 W/1 14" SPREAD 2.250"	53.750	
3/0 W/1 14" SPREAD 2.500"	54.000	
3/0 W/1 14" SPREAD 2.750"	54.250	
3/0 W/1 14" SPREAD 3.000"	54.500	

	UNIT SIZE	INSWING
	"A"	
SINGLE WITH TWO SIDELITES	3/0 W/2 10" SPREAD 0.000"	59.000
	3/0 W/2 10" SPREAD 0.250"	59.500
	3/0 W/2 10" SPREAD 0.500"	60.000
	3/0 W/2 10" SPREAD 0.750"	60.500
	3/0 W/2 10" SPREAD 1.000"	61.000
	3/0 W/2 10" SPREAD 1.250"	61.500
	3/0 W/2 10" SPREAD 1.500"	62.000
	3/0 W/2 10" SPREAD 1.750"	62.500
	3/0 W/2 10" SPREAD 2.000"	63.000
	3/0 W/2 10" SPREAD 2.250"	63.500
	3/0 W/2 10" SPREAD 2.500"	64.000
	3/0 W/2 10" SPREAD 2.750"	64.500
	3/0 W/2 10" SPREAD 3.000"	65.000
	3/0 W/2 12" SPREAD 0.000"	63.000
	3/0 W/2 12" SPREAD 0.250"	63.500
	3/0 W/2 12" SPREAD 0.500"	64.000
	3/0 W/2 12" SPREAD 0.750"	64.500
	3/0 W/2 12" SPREAD 1.000"	65.000
	3/0 W/2 12" SPREAD 1.250"	65.500
	3/0 W/2 12" SPREAD 1.500"	66.000
	3/0 W/2 12" SPREAD 1.750"	66.500
	3/0 W/2 12" SPREAD 2.000"	67.000
	3/0 W/2 12" SPREAD 2.250"	67.500
	3/0 W/2 12" SPREAD 2.500"	68.000
	3/0 W/2 12" SPREAD 2.750"	68.500
	3/0 W/2 12" SPREAD 3.000"	69.000
	3/0 W/2 14" SPREAD 0.000"	67.000
	3/0 W/2 14" SPREAD 0.250"	67.500
	3/0 W/2 14" SPREAD 0.500"	68.000
	3/0 W/2 14" SPREAD 0.750"	68.500
	3/0 W/2 14" SPREAD 1.000"	69.000
	3/0 W/2 14" SPREAD 1.250"	69.500
3/0 W/2 14" SPREAD 1.500"	70.000	
3/0 W/2 14" SPREAD 1.750"	70.500	
3/0 W/2 14" SPREAD 2.000"	71.000	
3/0 W/2 14" SPREAD 2.250"	71.500	
3/0 W/2 14" SPREAD 2.500"	72.000	
3/0 W/2 14" SPREAD 2.750"	72.500	
3/0 W/2 14" SPREAD 3.000"	73.000	

Frame Parts

Side Length

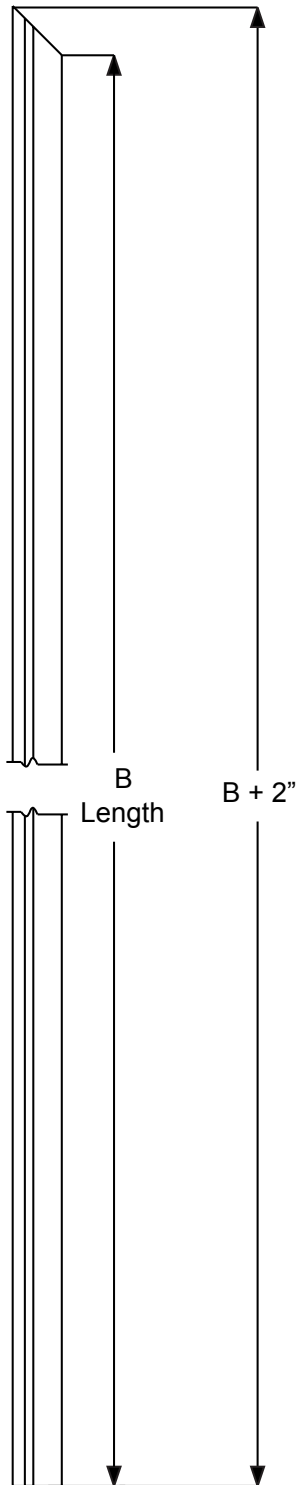

Frame Parts

	Unit Size	"B"
Inswing	6/6	78.530
	6/8	81.078
	7/0	85.078
	8/0	97.078
Outswing (Composite)	6/6	78.121
	6/8	80.669
	7/0	84.669
	8/0	96.669
Outswing (Aluminum)	6/6	77.546
	6/8	80.094
	7/0	84.094
	8/0	96.094
Inswing Units with Transoms	6/8	94.547

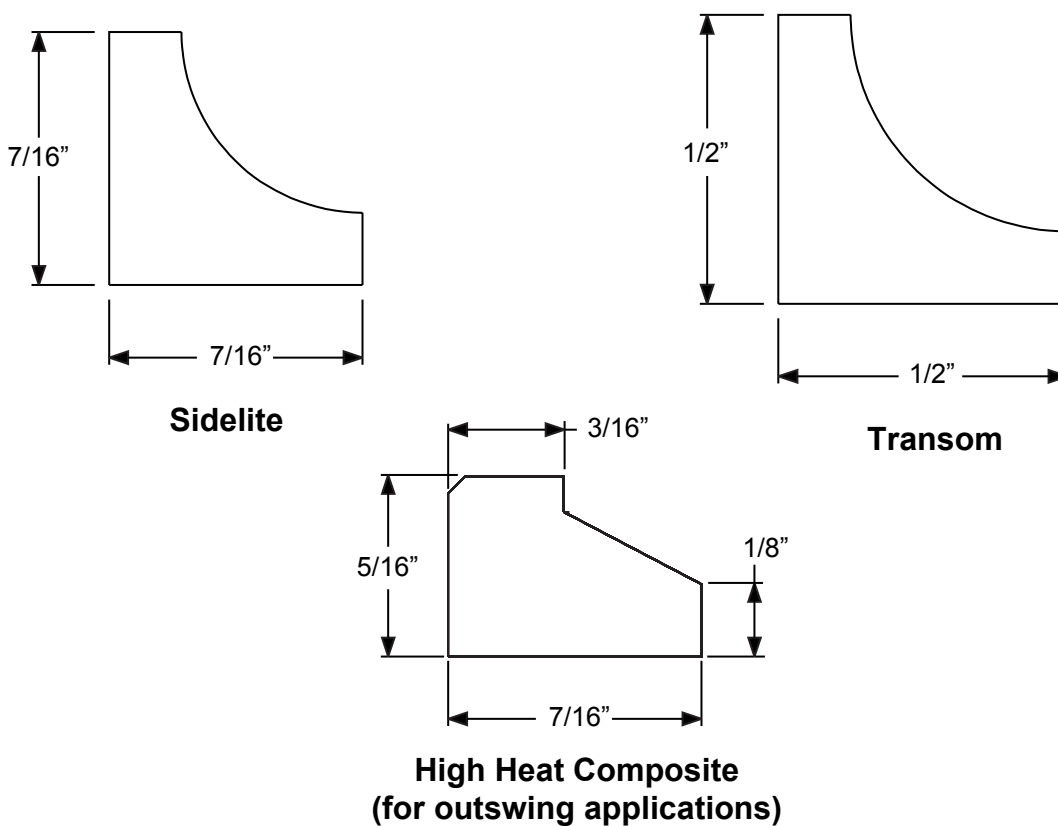

Frame Parts

Head Jamb Seal Pad
4-9/16" and 6-9/16" Jambs

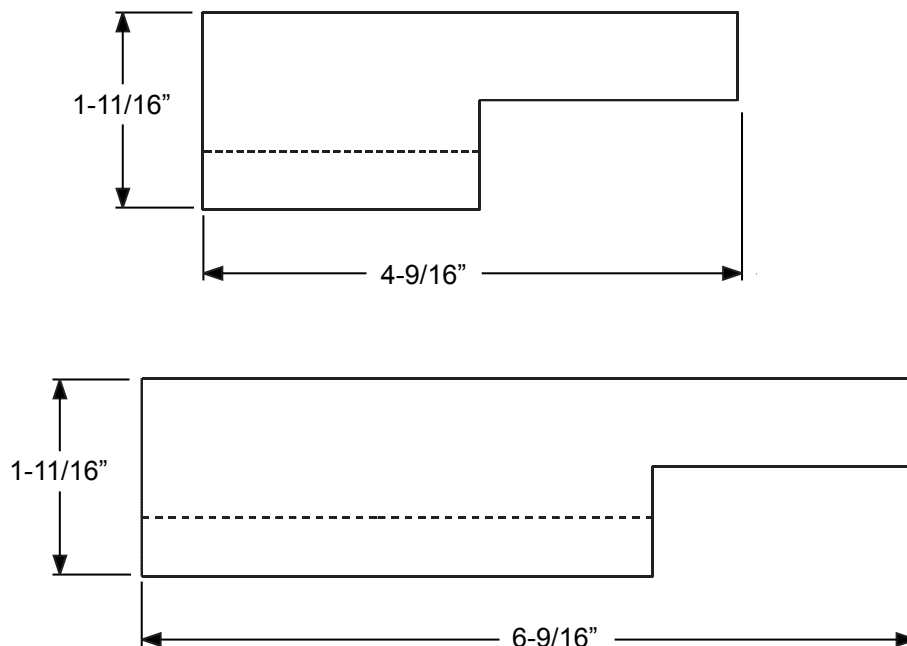

Mull Casing

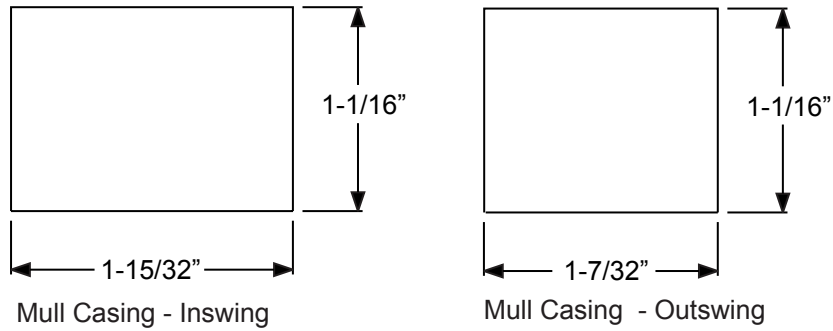

Length: Standard = 81-1/4"
 Transom = 95-3/4"
 8/0 Height = 98"

Wood Mull Casing

Frame Parts

Screen Track and Stop

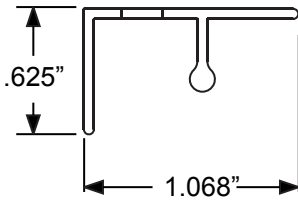

Screen Track

	Size	Length
Standard Mullion	4/8	56.938
	5/0	60.938
	5/4	64.938
	5/8	68.938
	6/0	72.938
Wide Mullion	4/8	57.438
	5/0	61.438
	5/4	65.438
	5/8	69.438
	6/0	73.438

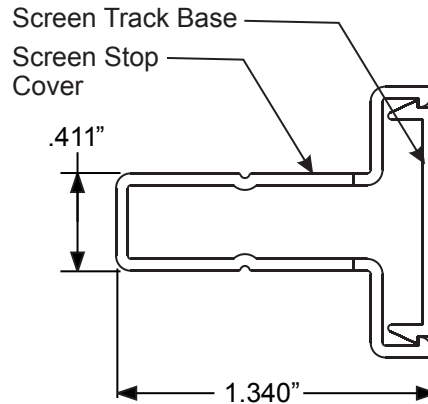

Triple Patio Screen Stop

	Base Length	Cover Length
6/6	77.141	77.906
6/8	79.688	80.453
7/0	83.688	84.453
8/0	95.688	96.453

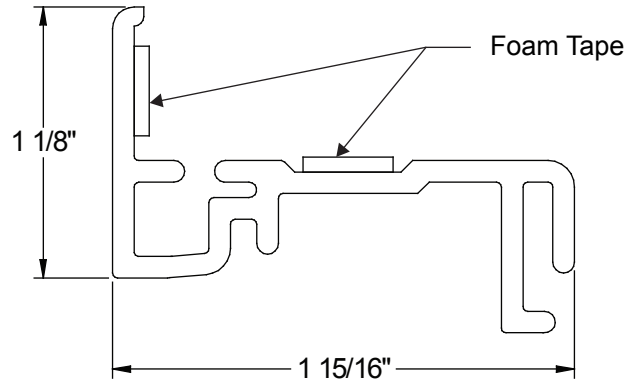

**Bottom Trim
Length = 37"**

Frame Parts

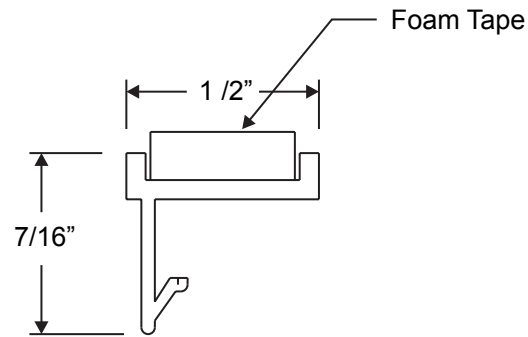

**Direct Set Sidelite Trim Kit
Length = 80" or 96"**