

THERMA TRU®

THERMA TRU DOORS

118 INDUSTRIAL DR., EDGERTON, OH 43517
TEL. (419)298-1740 FAX (419)

FIBERGLASS SIDE HINGE INSWING PATIO DOOR

"NON-IMPACT"

GENERAL NOTES

1. THIS PRODUCT ANCHORING DRAWING HAS BEEN DEVELOPED IN COMPLIANCE WITH THE 2004 FLORIDA BUILDING CODE EXCLUDING THE "HIGH VELOCITY HURRICANE ZONE".
2. PRODUCT ANCHORS SHALL BE AS LISTED AND SPACED AS SHOWN ON DETAILS. ANCHOR EMBEDMENT TO BASE MATERIAL SHALL BE BEYOND WALL DRESSING OR STUCCO.
3. WHERE SHIMS ARE USED, THEY MUST BE A "RIGID / STIFF" MATERIAL THAT COMPLIES WITH THE REQUIREMENTS OF THE FLORIDA BUILDING CODES.
4. CONDITIONS NOT COVERED BY THIS DRAWING ARE SUBJECT TO FURTHER ENGINEERING ANALYSIS.

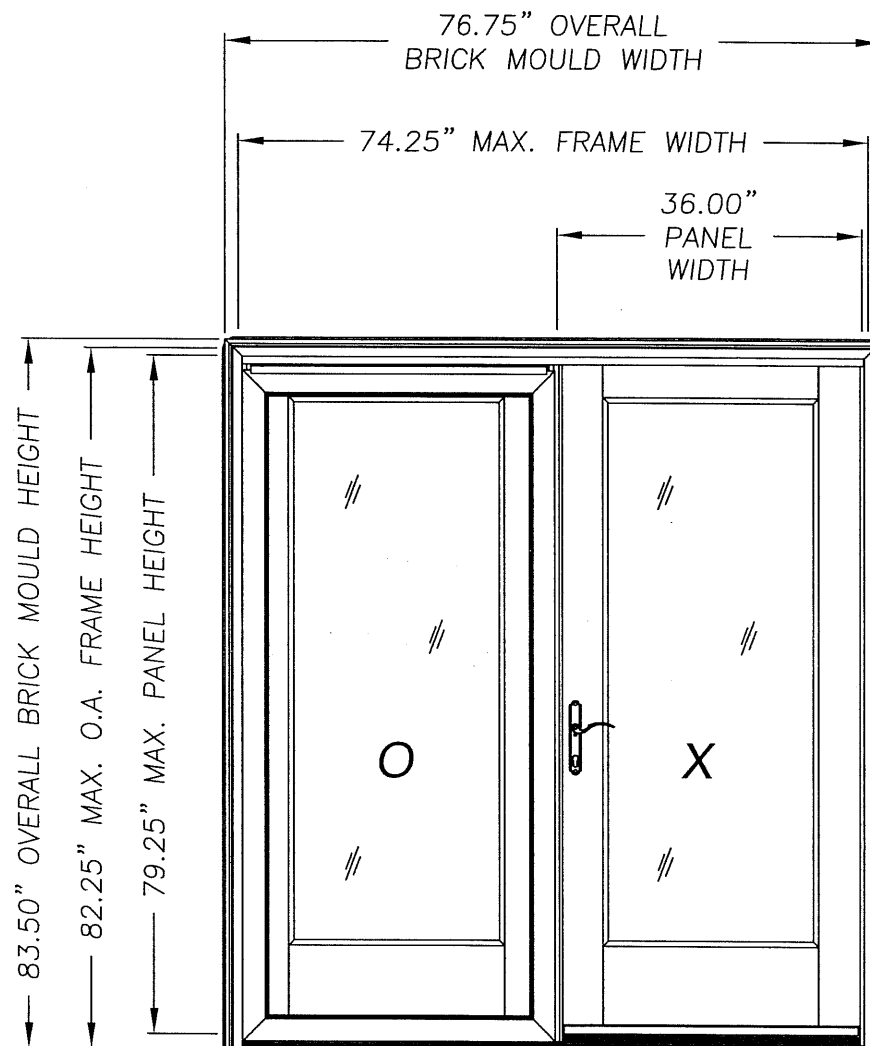

TABLE OF CONTENTS	
SHEET #	DESCRIPTION
1	TYPICAL ELEVATION, DESIGN PRESSURES & GENERAL NOTES
2	VERTICAL & HORIZONTAL CROSS SECTIONS & B.O.M.
3	BUCK AND FRAME ANCHORING

SWING	OVERALL FRAME DIMENSION	DESIGN PRESSURE (PSF)	
		POSITIVE	NEGATIVE
INSWING	74.25" X 82.25"	+ 45.0	- 45.0

Documents Prepared By:

R.W. BUILDING CONSULTANTS, INC.
P.O. Box 230 Valrico FL 33595
Phone No.: 813.659.9197
Florida Board of Professional Engineers
Certificate Of Authorization No. 9813
Wendell W. Honey 11-17-06
Wendell W. Honey, P.E. No. 54158

PRODUCT:
THERMA-TRU FIBERGLASS
SIDE HINGE INSWING
PATIO DOOR "NON-IMPACT"
PART OR ASSEMBLY:
TYPICAL ELEVATION, DESIGN
PRESSURES & GENERAL NOTES

NO.	DATE	BY	REVISIONS

DATE: 11/17/06
SCALE: N.T.S.
DWG. BY: EW
CHK. BY: WWH
DRAWING NO.: FL-3068
SHEET 1 OF 3

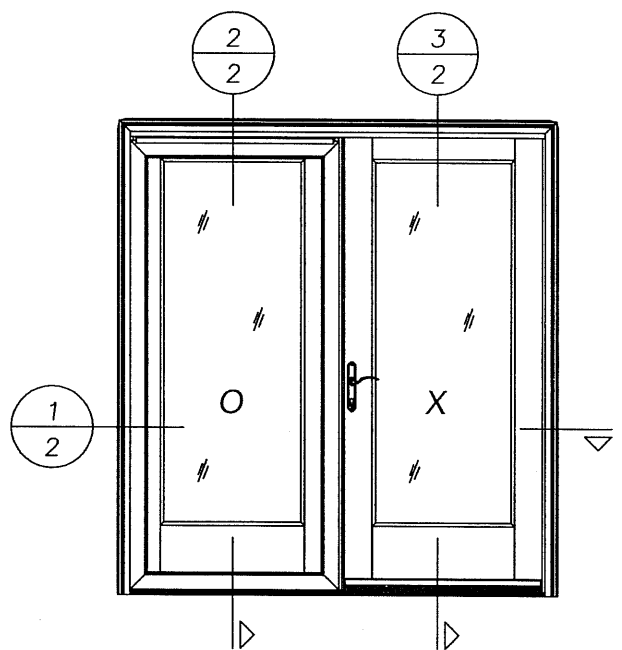

Item	DESCRIPTION	Material
1	MASONRY	CONCRETE
2	2X BUCK	WOOD
3	1/4" x 3-1/4" ELCO TAPCON OR EQUAL	STEEL
4	MAX. 1/4" SHIM SPACE	WOOD
5	#8 x 2-1/2" PPH WOOD SCREW	STEEL
6	#8 x 2" PPH WOOD SCREW	STEEL
7	1/4" x 2-1/4" TAPCON	STEEL

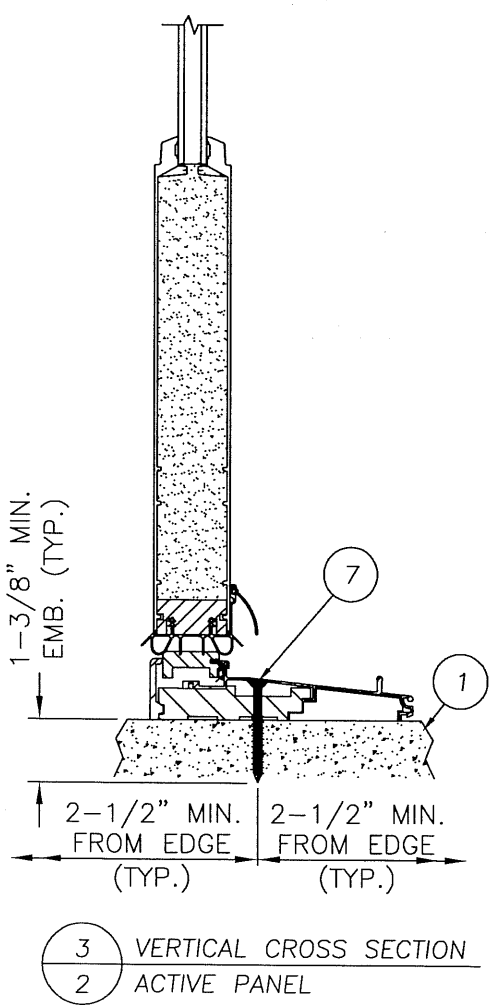
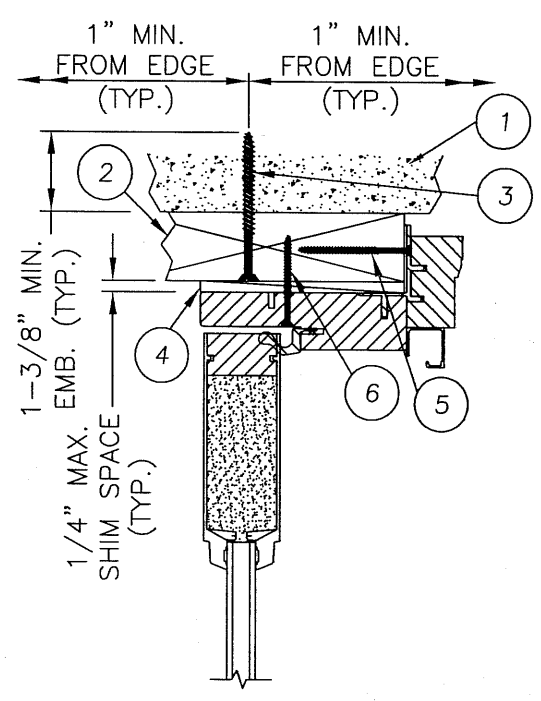
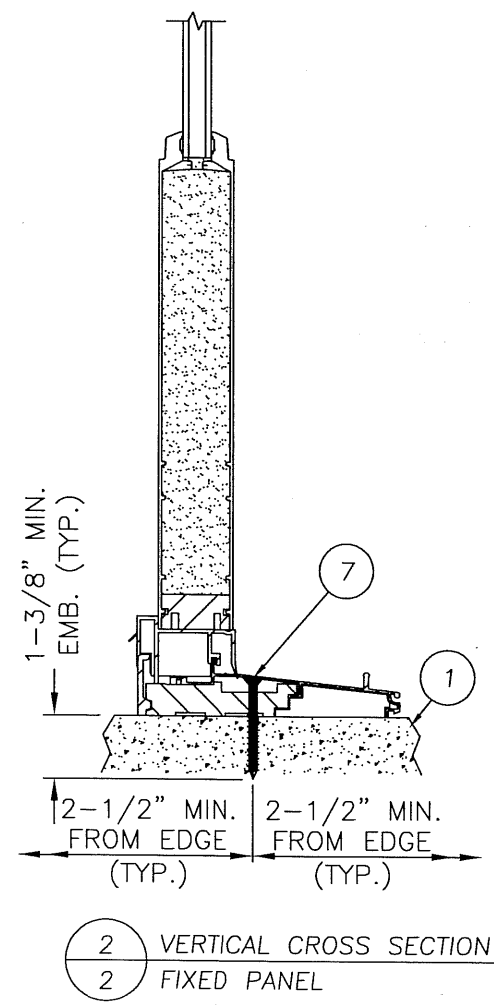
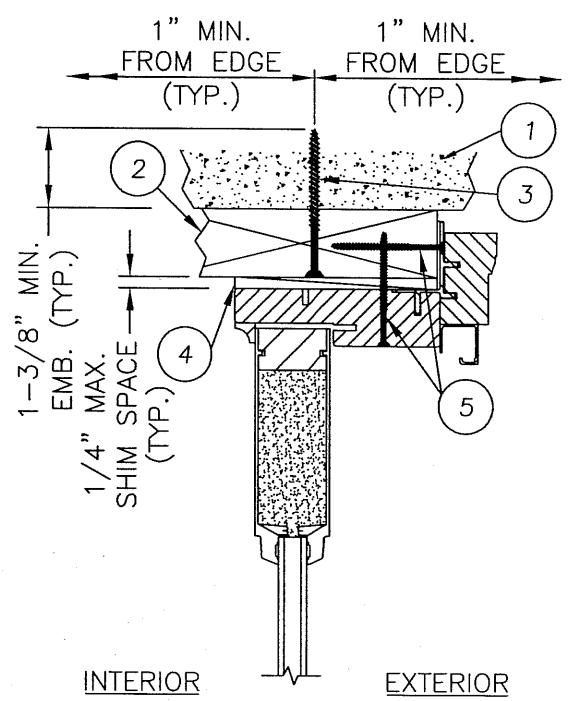
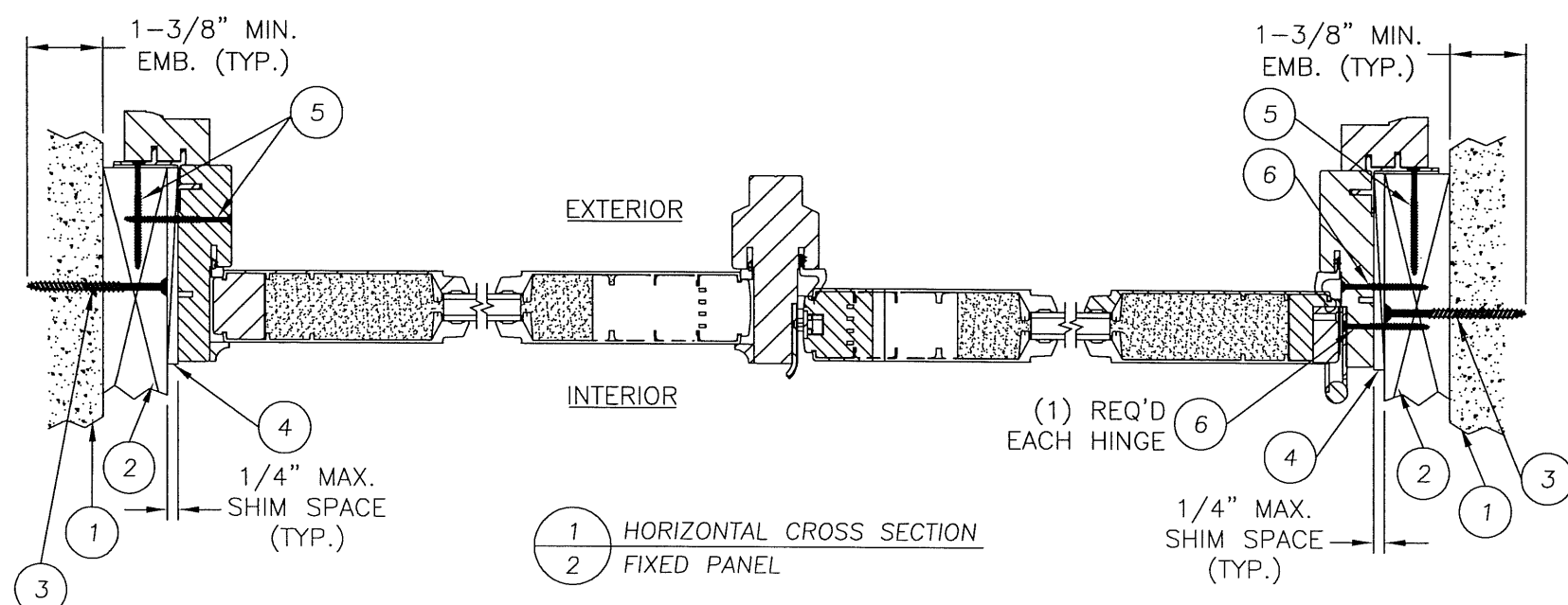

1 HORIZONTAL CROSS SECTION
2 FIXED PANEL

2 VERTICAL CROSS SECTION
2 FIXED PANEL

3 VERTICAL CROSS SECTION
2 ACTIVE PANEL

Documents Prepared By:

RW BUILDING CONSULTANTS, INC.
P.O. Box 230 Valrico FL 33595
Phone No.: 813.659.9197
Florida Board of Professional Engineers
Certificate Of Authorization No. 9813
Wendell W. Haney 11-17-06
Wendell W. Haney, P.E. No. 54158

PRODUCT:
THERMA-TRU FIBERGLASS
SIDE HINGE INSWING
PATIO DOOR "NON-IMPACT"
PART OR ASSEMBLY:
ANCHORING SECTIONS
AND LOCATIONS

NO.	DATE	BY	REVISIONS

DATE: 11/17/06
SCALE: N.T.S.
DWG. BY: EW
CHK. BY: WWH
DRAWING NO.: FL-3068
SHEET 2 OF 3

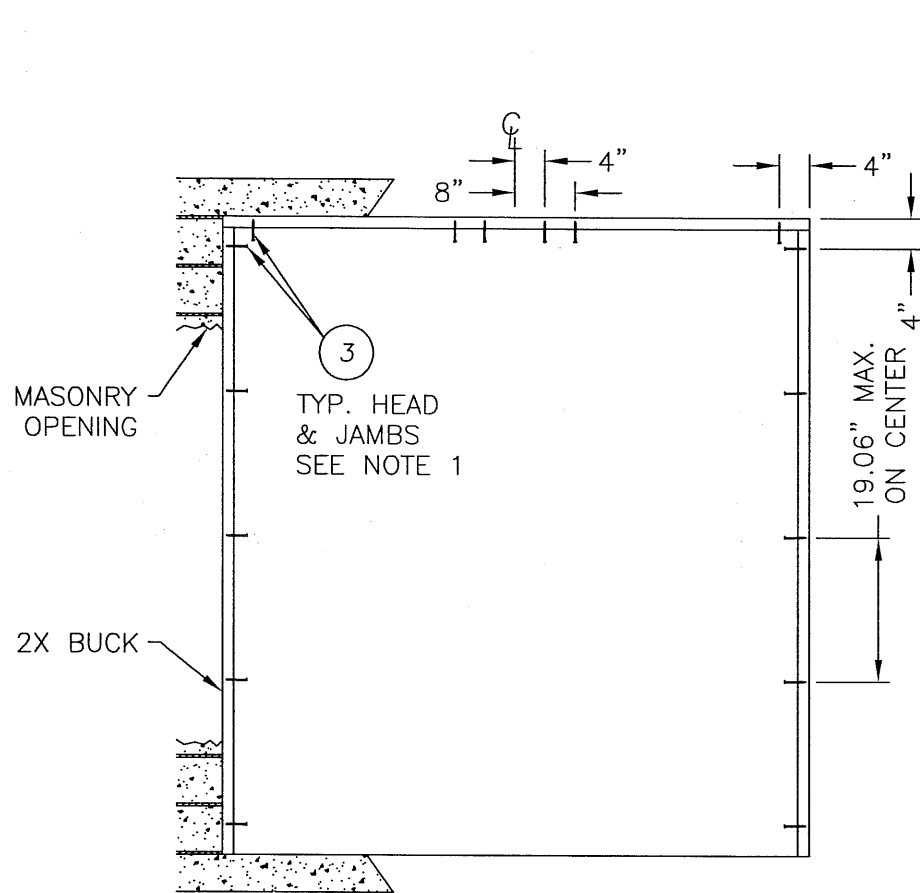

BUCK ANCHORING

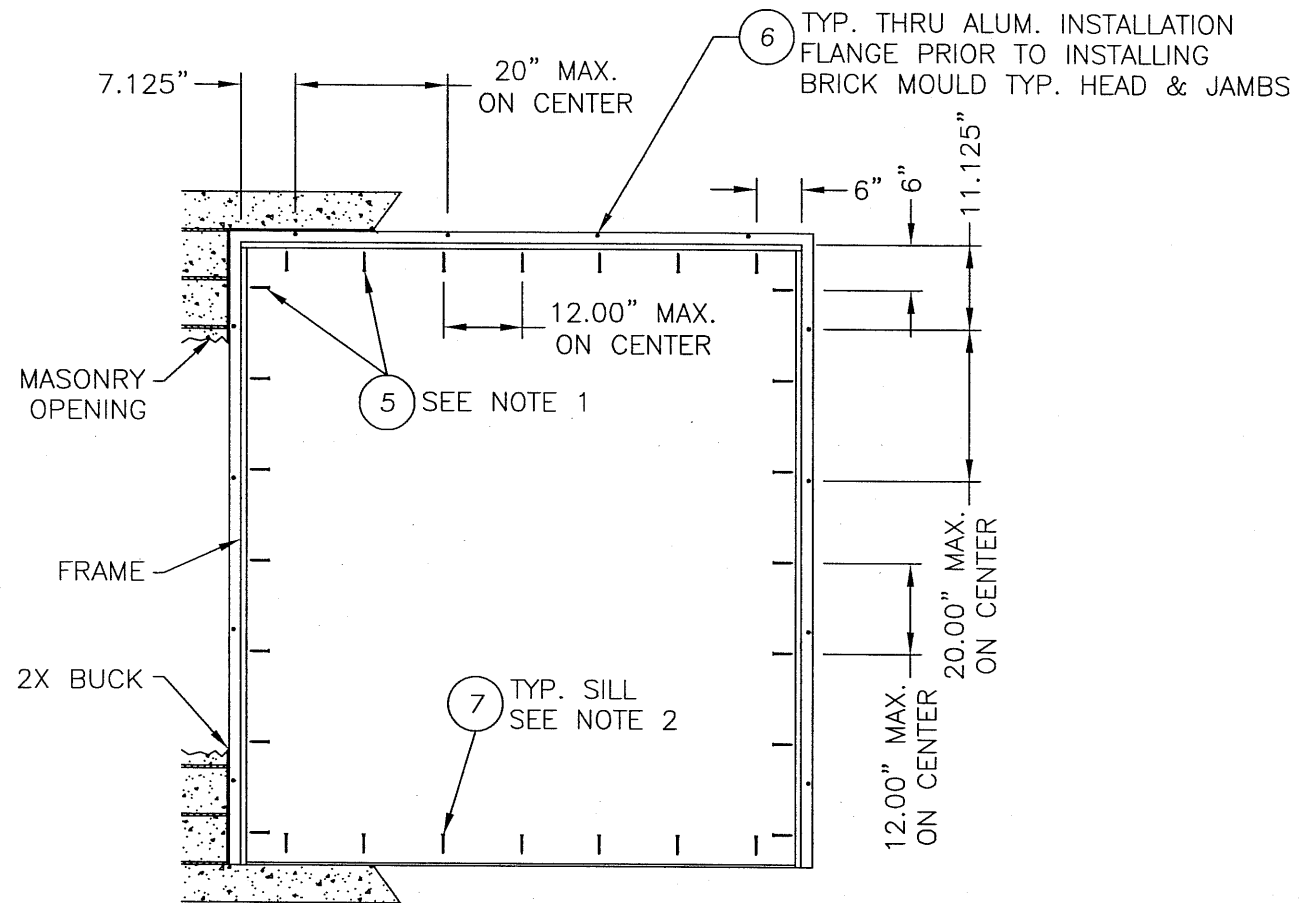

FRAME ANCHORING

NOTES:

1. 1/4" ELCO TAPCON ANCHORING 2X BUCK REQUIRE A MINIMUM 1" CLEARANCE TO MASONRY EDGES AND A MINIMUM 4" CLEARANCE TO ADJACENT TAPCONS. SUBSTITUTION OF EQUAL CONCRETE SCREWS FROM A DIFFERENT SUPPLIER MAY HAVE DIFFERENT EDGE DISTANCE AND CENTER DISTANCE REQUIREMENTS.
2. 1/4" CONCRETE SCREWS ANCHORING FRAME AND/OR SILL REQUIRE A MINIMUM 2-1/2" CLEARANCE TO MASONRY EDGES AND A MINIMUM 3" CLEARANCE TO ADJACENT CONCRETE SCREWS UNLESS OTHERWISE NOTED BY CONCRETE SCREW MANUFACTURER.

Documents Prepared By:

RW BUILDING CONSULTANTS, INC.
 P.O. Box 230 Vairico FL, 33595
 Phone No.: 813.659.9197
 Florida Board of Professional Engineers
 Certificate of Authorization No. 9813
 Wendell W. Haynes P.E. No. 54158
 11-17-06

PRODUCT: THERMA-TRU FIBERGLASS SIDE HINGE INSWING PATIO DOOR "NON-IMPACT"
 PART OR ASSEMBLY: BUCK & FRAME ANCHORING

NO.	DATE	BY	REVISIONS

DATE: 11/17/06
 SCALE: N.T.S.
 DWG. BY: EW
 CHK. BY: WWH
 DRAWING NO.: FL-3068
 SHEET 3 OF 3