

THERMA-TRU CORPORATION

118 INDUSTRIAL DRIVE
 EDGERTON, OHIO 43517
 PH. (419) 298-1740

3'0 X 6'8
"CLASSIC CRAFT"
FIBERGLASS SINGLE DOOR
IN SWING / OUT SWING
"IMPACT"

GENERAL NOTES

1. THIS PRODUCT HAS BEEN EVALUATED AND IS IN COMPLIANCE WITH THE FLORIDA BUILDING CODE EXCLUDING THE "HIGH VELOCITY HURRICANE ZONE".
2. PRODUCT ANCHORS SHALL BE AS LISTED AND SPACED AS SHOWN ON DETAILS. ANCHOR EMBEDMENT TO BASE MATERIAL SHALL BE BEYOND WALL DRESSING OR STUCCO.
3. WHEN USED IN WIND-BORNE DEBRIS REGIONS THIS PRODUCT COMPLIES WITH SECTION 1609.1.4 OF THE FLORIDA BUILDING CODE AS AN IMPACT RESISTANT PRODUCT AND DOES NOT REQUIRE THE USE OF AN EXTERNAL IMPACT RESISTANT COVERING. THIS PRODUCT DOES NOT MEET THE REQUIREMENTS FOR ENHANCED PROTECTION OF ESSENTIAL FACILITIES AS DEFINED IN ASTM E1996.
4. FOR 2X STUD FRAMING CONSTRUCTION, ANCHORING OF THESE UNITS SHALL BE THE SAME AS THAT SHOWN FOR 2X BUCK MASONRY CONSTRUCTION.
5. CONDITIONS NOT COVERED BY THIS DRAWING ARE SUBJECT TO FURTHER ENGINEERING ANALYSIS.

TABLE OF CONTENTS	
1	TYPICAL ELEVATION, DESIGN PRESSURES & GENERAL NOTES
2	VERTICAL & HORIZONTAL CROSS SECTIONS
3	BUCK & FRAME ANCHORING
4	COMPONENTS
5	BILL OF MATERIALS & COMPONENTS

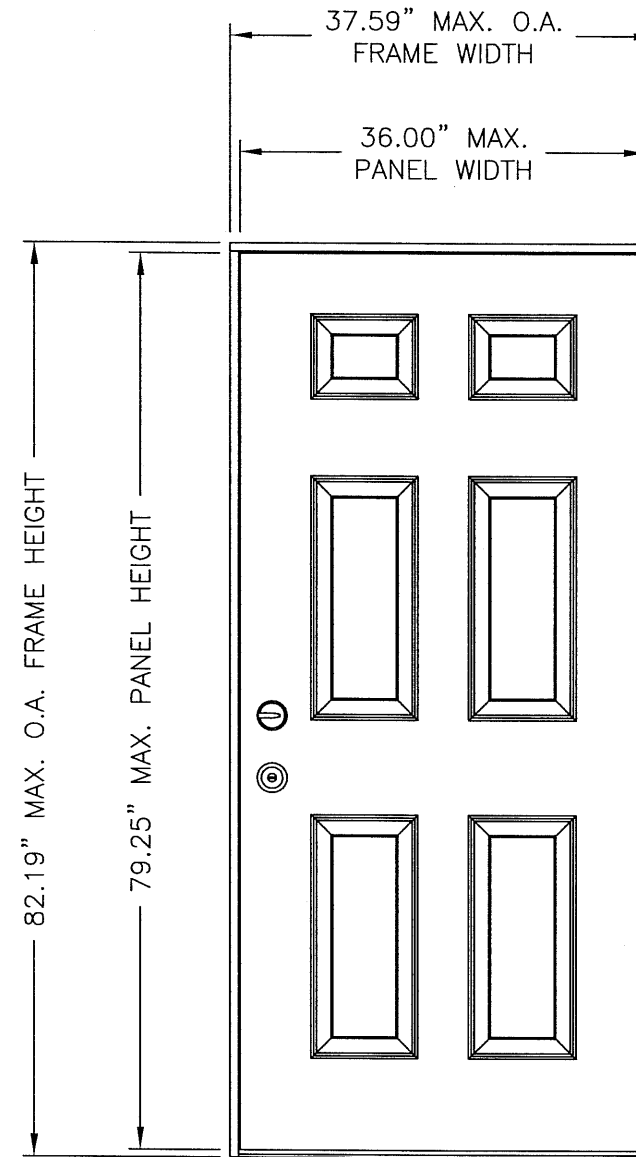

SINGLE OPAQUE DOOR
 VIEWED FROM EXTERIOR

SWING	OVERALL FRAME DIMENSION	DESIGN PRESSURE (PSF)	
		POSITIVE	NEGATIVE
IN SWING	37.59" x 82.19"	+67.00	-67.00
OUT SWING	37.59" x 80.69"	+67.00	-67.00

Documents Prepared By:

RW BUILDING CONSULTANTS, INC.
 P.O. Box 230 Valrico FL 33595
 Phone No.: 813.669.9197
 Florida Board of Professional Engineers
 Certificate of Authorization No. 9813
Wendell W. Hoppey 11-18-05
 Wendell W. Hoppey, P.E. NO. 54158

PRODUCT:
 3'0 X 6'8 "CLASSIC CRAFT"
 FIBERGLASS SINGLE DOOR
 IN SWING/OUT SWING "IMPACT"

PART OR ASSEMBLY:
 TYPICAL ELEVATION, DESIGN
 PRESSURES & GENERAL NOTES

NO.	DATE	BY	REVISIONS

DATE: 11/16/05

SCALE: N.T.S.

DWG. BY: AEM

CHK. BY: WWH

DRAWING NO.:
 FL-674

SHEET 1 OF 5

R:\PROJ 801 - 900VFB63V-L-6/4.VL-6/4-I.DWG

NOTES

1. THE HEAD JAMB IS ATTACHED TO THE SIDE JAMBS WITH (3) 16GA. x 1/2" CROWN x 2" STAPLES AT BOTH SIDES.
2. THE THRESHOLD IS ATTACHED TO THE SIDE JAMBS WITH (2) 16GA. x 1/2" CROWN x 2-1/2" STAPLES AT BOTH SIDES.

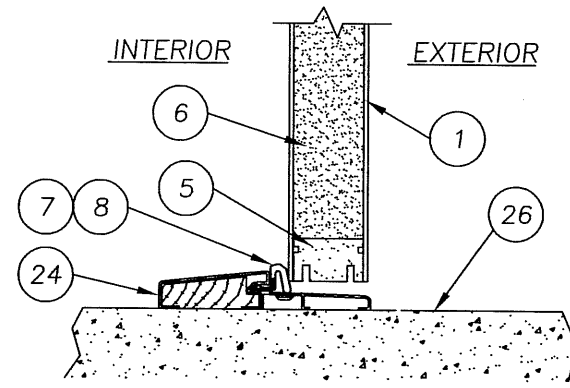
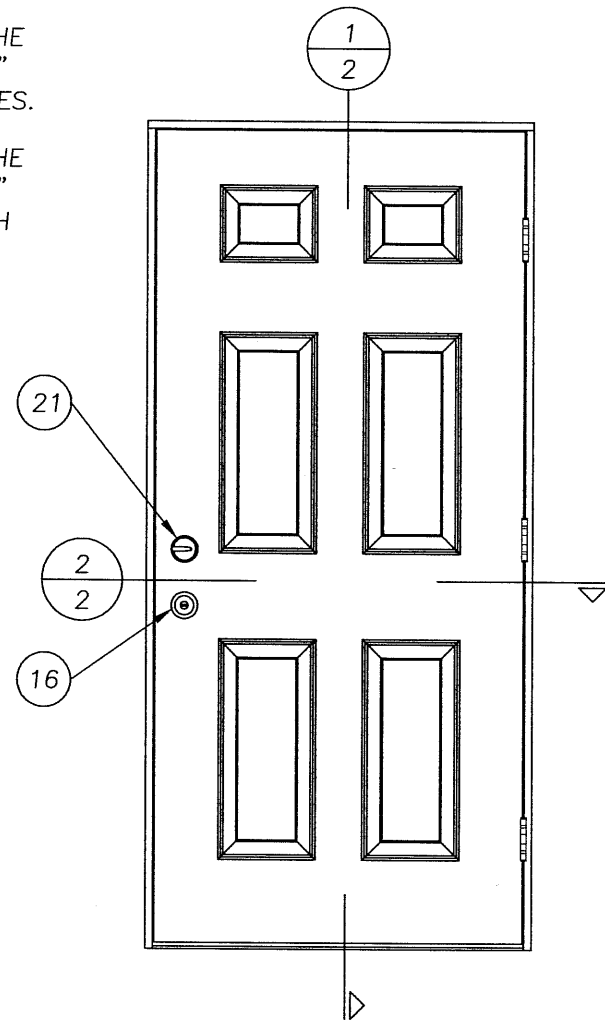

1 VERTICAL CROSS SECTION
2 @ SILL OUTSWING THRESHOLD

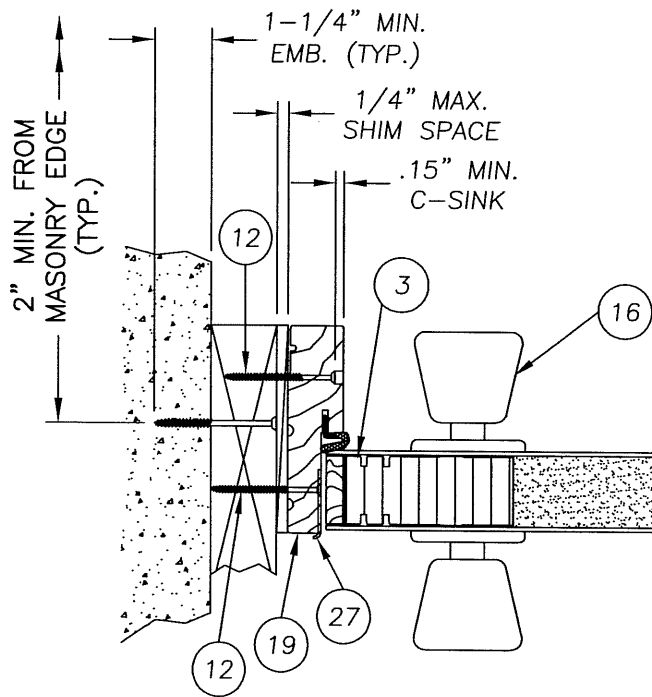
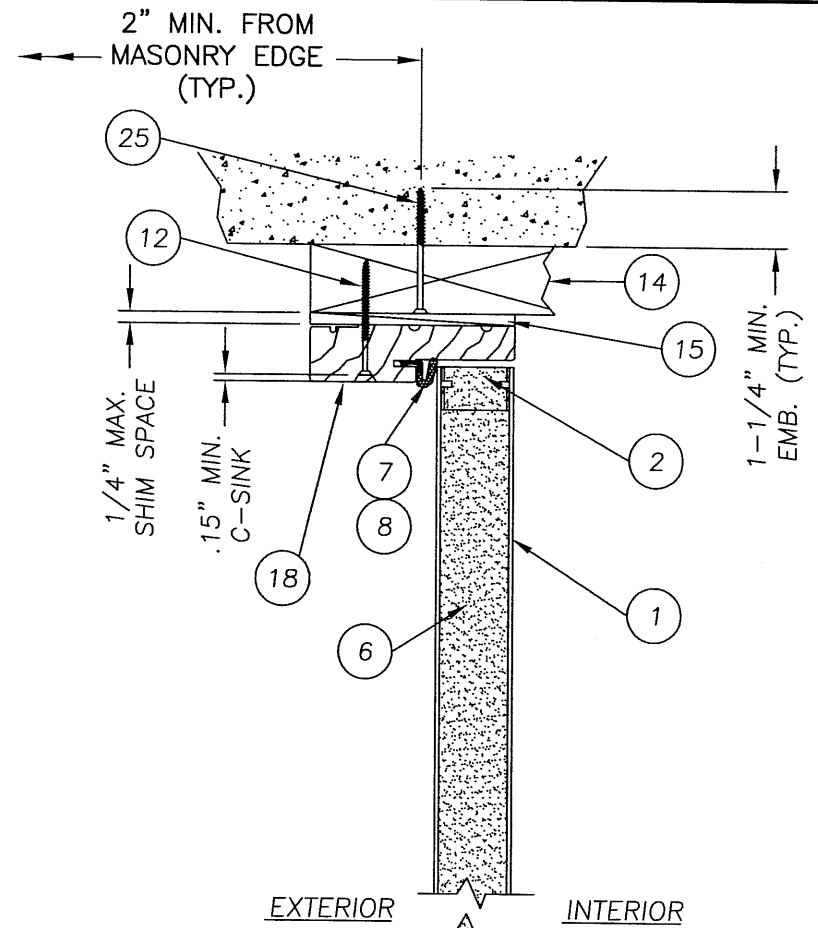

2 HORIZONTAL CROSS SECTION
2 INSWING CONFIGURATION

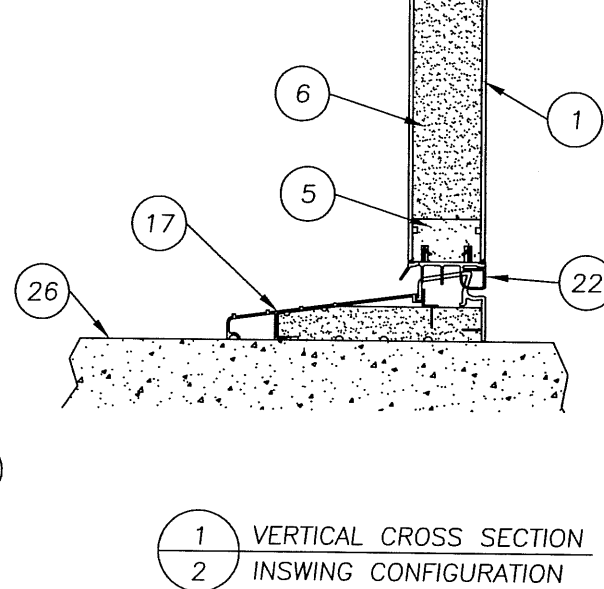
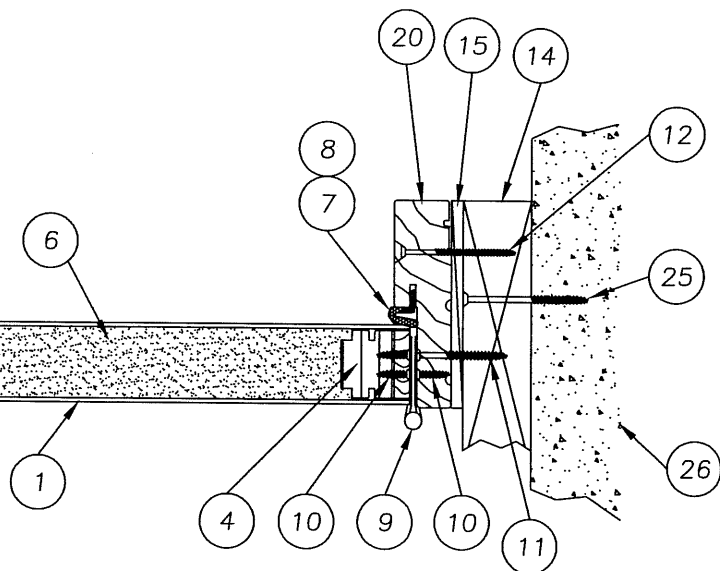

1 VERTICAL CROSS SECTION
2 INSWING CONFIGURATION

Documents Prepared By:

RW BUILDING CONSULTANTS, INC.
P.O. Box 230 Valrico FL, 33595
Phone No.: 813.659.9197
Florida Board of Professional Engineers
Certificate of Authorization No. 9813
Wendell W. Haney 11-18-05
Wendell W. Haney, P.E. No. 54158

PRODUCT:
3'0 X 6'8 "CLASSIC CRAFT"
FIBERGLASS SINGLE DOOR
INSWING/OUTSWING "IMPACT"

PART OR ASSEMBLY:
VERTICAL & HORIZONTAL
CROSS SECTIONS

NO.	DATE	BY	REVISIONS

DATE: 11/16/05
SCALE: N.T.S.
DWG. BY: AEM
CHK. BY: WWH
DRAWING NO.: FL-674
SHEET 2 OF 5

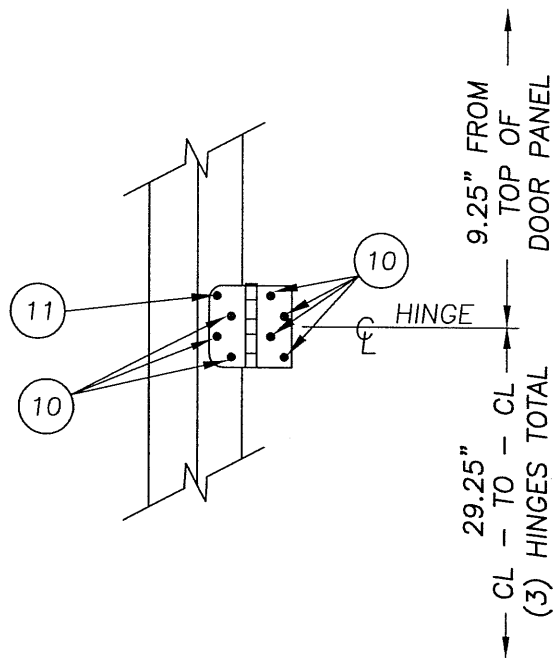

HINGE DETAIL

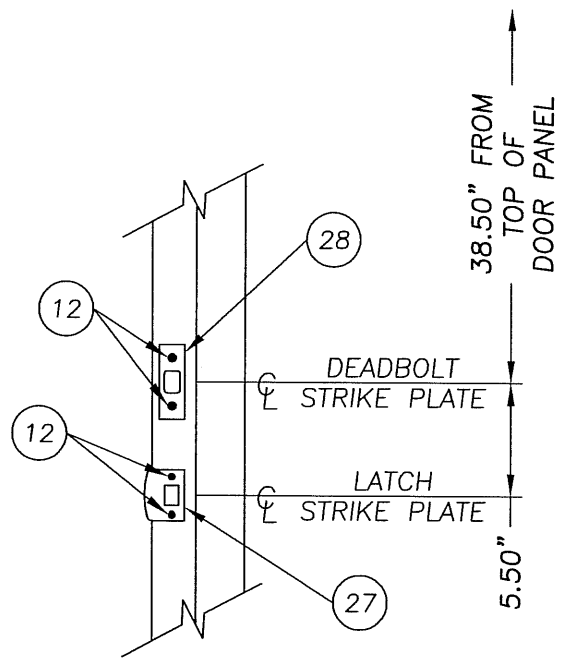

STRIKE PLATE DETAIL

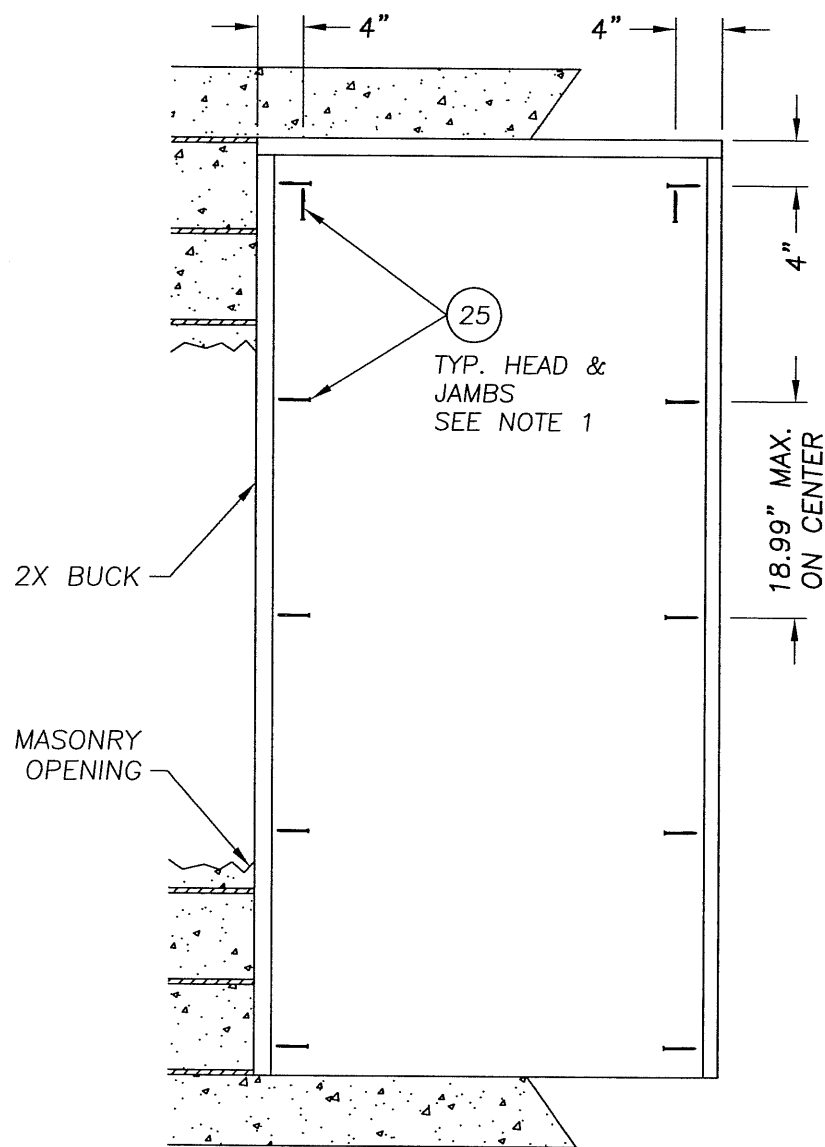

BUCK ANCHORING

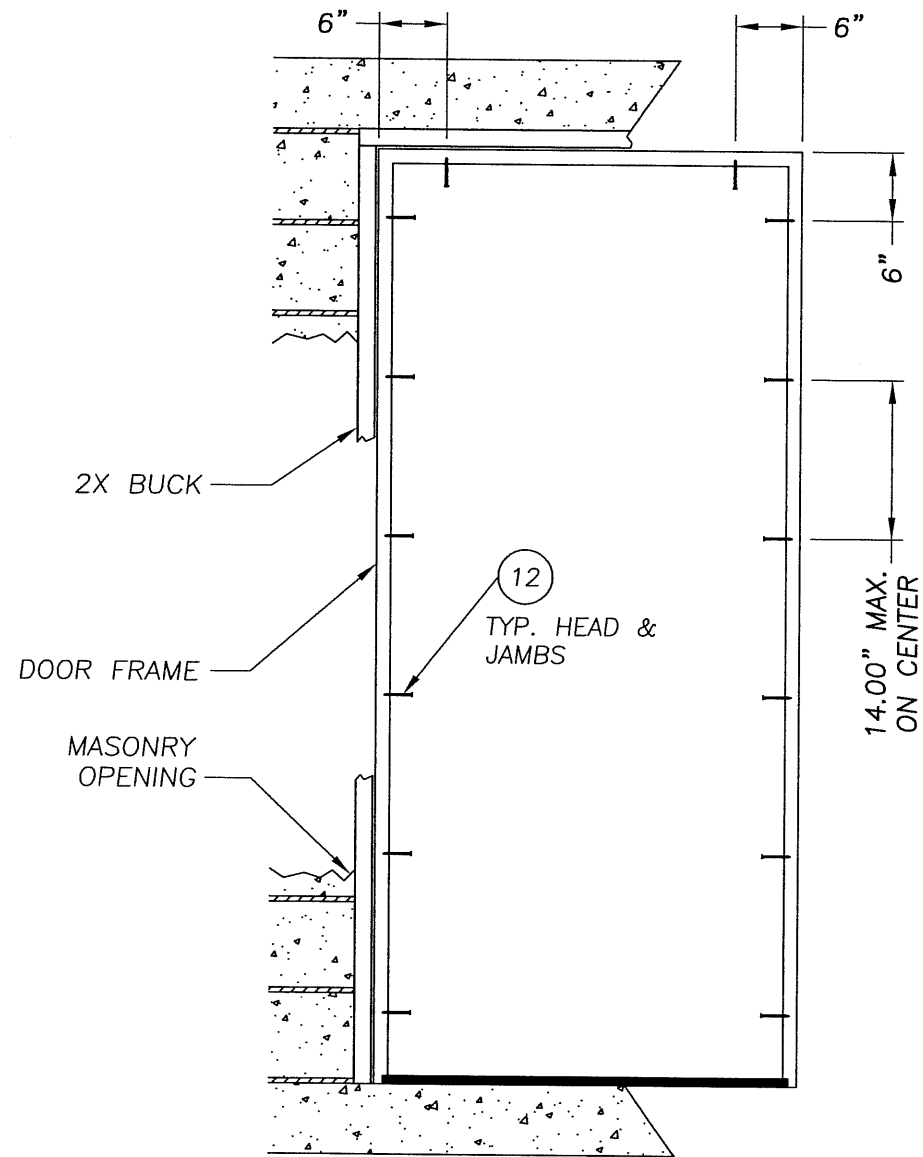

FRAME ANCHORING

NOTES:

1. 3/16" TAPCONS REQUIRE A MINIMUM 2" CLEARANCE TO MASONRY EDGES AND A MINIMUM 2-5/16" CLEARANCE TO ADJACENT TAPCONS.

Documents Prepared By:

RW BUILDING CONSULTANTS, INC.
 P.O. Box 230 Valrico FL, 33595
 Phone No.: 813.659.9197
 Florida Board of Professional Engineers
 Certificate of Authorization No. 9813
Wendell W. Haney 11-18-05
 Wendell W. Haney, P.E. (No. 54158)

PRODUCT:
 3'0" X 6'8" "CLASSIC CRAFT"
 FIBERGLASS SINGLE DOOR
 INSWING/OUTSWING "IMPACT"

PART OR ASSEMBLY:
 BUCK & FRAME
 ANCHORING

NO.	DATE	BY	REVISIONS

DATE: 11/16/05

SCALE: N.T.S.

DWG. BY: AEM

CHK. BY: WWH

DRAWING NO.:

FL-674

SHEET 3 OF 5

\\rwbcsrv\vwbc\Proj 801 - 900\p863\FL-674\FL-674-3.dwg

ITEM	DESCRIPTION	MATERIAL
1	C.C. DOOR SKIN .098" MIN. THK. FIBERGLASS BY THERMA-TRU with yield strength $F_y(\text{min.})=2,000$ psi	FIBERGLASS
2	C.C. TOP RAIL	WOOD COMPOSITE
3	C.C. LATCH STILE	LSL / OAK
4	C.C. HINGE STILE	LSL / OAK
5	C.C. BOTTOM RAIL	WOOD COMPOSITE
6	POLYURETHANE FOAM (BASF, 1.9lbs. DENSITY)	FOAM
7	SHORT REACH COMPRESSION WEATHERSTRIP (THERMA-TRU) FOAM CELL W/VINYL JACKET	FOAM
8	LONG REACH COMPRESSION WEATHERSTRIP (THERMA-TRU) FOAM CELL W/VINYL JACKET	FOAM
9	4" x 4" HINGE .097" THK. (THERMA-TRU)	STEEL
10	#10 x 3/4" PFH WS	STEEL
11	#10 x 2" PFH WS	STEEL
12	#8 x 2 1/2" PFH WS	STEEL
13	NOT USED	-
14	2x BUCK	WOOD
15	MAX. 1/4" SHIM	WOOD
16	KWIKSET TITAN 700 SERIES PASSAGE LOCK	-
17	SELF ADJUSTING INSWING SADDLE THRESHOLD (.45" WALL AL. - .080" WALL VINYL)	ALUM./WOOD/VINYL
18	HEADER (THERMA-TRU, FINGER JOINT PONDEROSA PINE)	WOOD
19	STRIKE JAMB (THERMA-TRU, FINGER JOINT PONDEROSA PINE)	WOOD
20	HINGE JAMB (THERMA-TRU, FINGER JOINT PONDEROSA PINE)	WOOD
21	KWIKSET TITAN 700 SERIES DEADBOLT	-
22	INSWING DOOR BOTTOM SWEEP (.080" MAX. - .034" MIN. WALL VINYL)	VINYL
23	NOT USED	-
24	ONE PIECE BUMP FACE THRESHOLD (THERMA-TRU) .050" WALL AL.	ALUM. / WOOD
25	3/16" x 2-3/4" TAPCON	STEEL
26	MASONRY	CONCRETE
27	LATCH STRIKE PLATE	STEEL
28	DEADBOLT STRIKE PLATE	STEEL

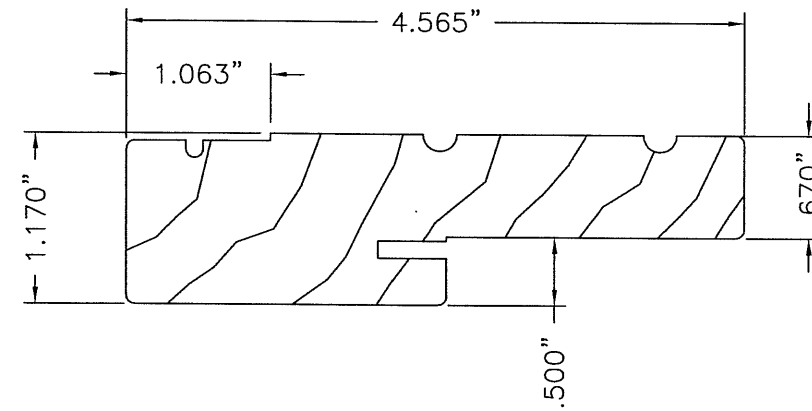

18 19 20 HEAD, LATCH & HINGE JAMB

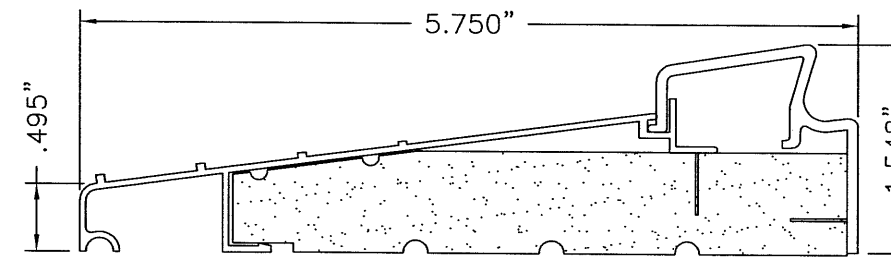

17 SELF ADJUSTING SADDLE THRESHOLD

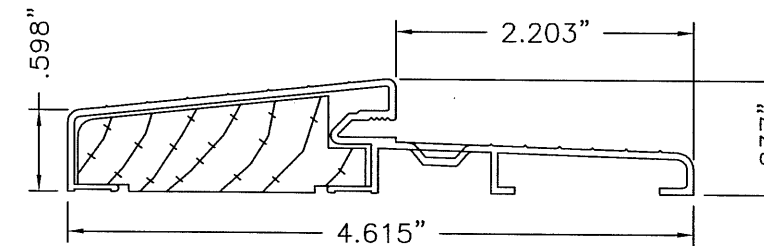

24 LOW PROFILE OUTSWING BUMP FACE

Documents Prepared By:

RW BUILDING CONSULTANTS, INC.
P.O. Box 230 Vairico FL, 33595
Phone No.: 813.659.9197
Florida Board of Professional Engineers
Certificate of Authorization No. 9813
11-18-05
Wendell W. Haney, P.E. No. 54158

PRODUCT:

3'0 X 6'8 "CLASSIC CRAFT"
FIBERGLASS SINGLE DOOR
INSWING/OUTSWING "IMPACT"

PART OR ASSEMBLY:

BILL OF MATERIALS &
COMPONENTS

NO.	DATE	BY

REVISIONS

DATE: 11/16/05

SCALE: N.T.S.

DWG. BY: AEM

CHK. BY: WWH

DRAWING NO.:

FL-674

SHEET 5 OF 5