

THERMA-TRU CORPORATION

118 INDUSTRIAL DRIVE
EDGERTON, OHIO 43517
PH. (419) 298-1740

"SLIDING PATIO DOOR FRAME ANCHORING"

GENERAL NOTES

1. THIS PRODUCT HAS BEEN EVALUATED AND IS IN COMPLIANCE WITH THE FLORIDA BUILDING CODE EXCLUDING THE "HIGH VELOCITY HURRICANE ZONE".
2. SEPARATE PRODUCT APPROVALS FOR EACH THERMA-TRU DOOR PRODUCT USED WITH THIS ANCHORING APPROVAL MUST BE SUBMITTED WITH THIS PRODUCT APPROVAL. CONSTRUCTION OF THE ASSEMBLY MUST BE IN ACCORDANCE WITH THE CONSTRUCTION OF THE COMPANION DOOR PRODUCT APPROVAL SUBMITTED.
3. THE DESIGN PRESSURE RATING OF THE TOTAL ASSEMBLY SHALL BE THE LESSER OF THE DP RATING OF THE FRAME ANCHORING SHOWN IN THIS APPROVAL OR THE DP RATING OF THE PRODUCT APPROVAL FOR THE DOOR PRODUCT USED.
4. MAIN MEMBER (BUCK OR STUD) FRAMING IS SPRUCE-PINE-FIR (SG = 0.42) OR BETTER.
5. PRODUCT ANCHORS SHALL BE AS LISTED AND SPACED AS SHOWN ON DETAILS. ANCHOR EMBEDMENT TO BASE MATERIAL SHALL BE BEYOND WALL DRESSING OR STUCCO.
6. THIS FRAME ANCHORING APPROVAL ADDRESSES TRANSFER OF WIND LOADS TO THE MAIN STRUCTURE. THE COMPANION DOOR PRODUCT APPROVAL SUBMITTED MUST BE APPROVED IN THE SAME OR SMALLER SIZE, SAME CONFIGURATION AND FRAME MATERIAL.
7. CONDITIONS NOT COVERED BY THIS DRAWING ARE SUBJECT TO FURTHER ENGINEERING ANALYSIS.

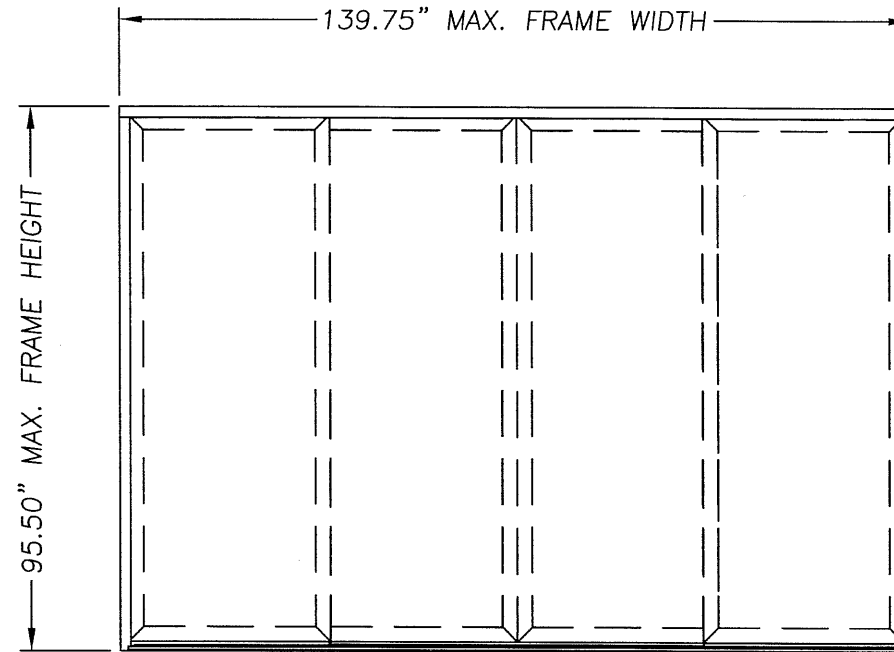

FOUR PANEL

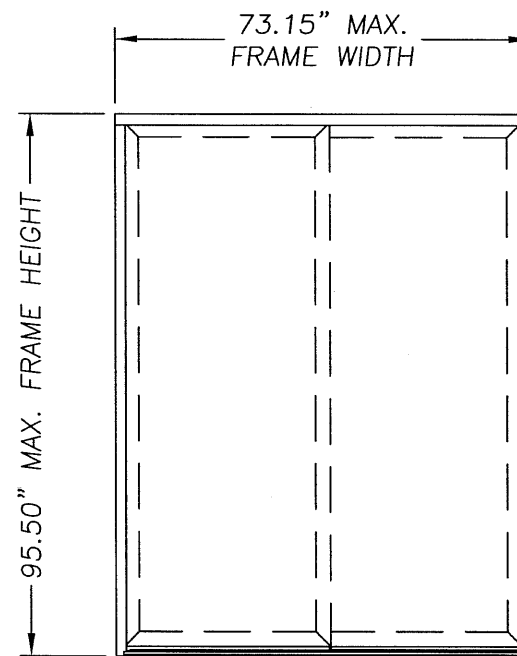

TWO PANEL

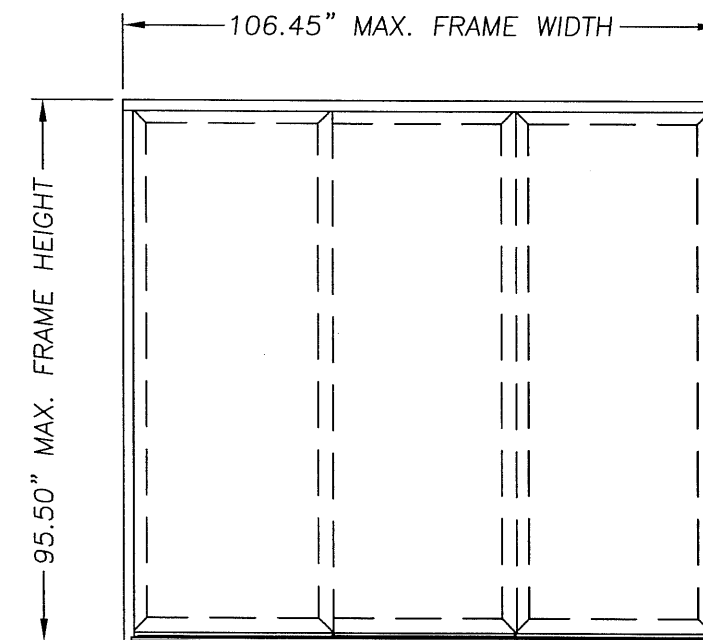

THREE PANEL

USABLE CONFIGURATIONS: X0, OX, OOX, X00, OX0, OXXO

TABLE OF CONTENTS	
SHEET #	DESCRIPTION
1	TYPICAL ELEVATION, DESIGN PRESSURES & GENERAL NOTES
2	ANCHOR CROSS SECTION MASONRY IN/OUTSWING WOOD FRAME
3	ANCHOR CROSS SECTION WOOD/STL. STUD IN/OUTSWING WOOD FRAME

UNIT TYPE	MAXIMUM OVERALL NOMINAL SIZE	DESIGN PRESSURE	
		POSITIVE	NEGATIVE
FOUR PANEL	139.75" x 95.50"	+50.0 PSF	-50.0 PSF
THREE PANEL	106.45" x 95.50"	+50.0 PSF	-50.0 PSF
TWO PANEL	73.15" x 95.50"	+50.0 PSF	-50.0 PSF

Documents Prepared By:

RW BUILDING CONSULTANTS, INC.
P.O. Box 230 Valrico, FL 33595
Phone No.: 813.656.9197

Florida Board of Professional Engineers
Certificate of Authorization No. 9813

Wendell W. Haney
Wendell W. Haney, P.E. No. 54158

PRODUCT: THERMA-TRU SLIM-LINE
PATIO DOOR
SYSTEM ANCHORING

PART OR ASSEMBLY:
TYPICAL ELEVATION, DESIGN
PRESSURES & GENERAL NOTES

NO.	DATE	BY	REVISIONS

DATE: 09/22/05

SCALE: N.T.S.

DWG. BY: AEM

CHK. BY: WWH

DRAWING NO.:

FL-626

SHEET 1 OF 3

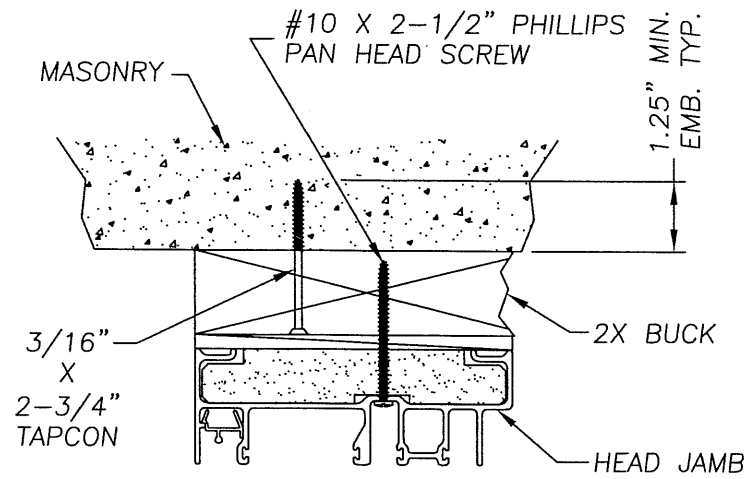

1 HORIZONTAL CROSS SECTION
2 ACTIVE / FIXED PANEL

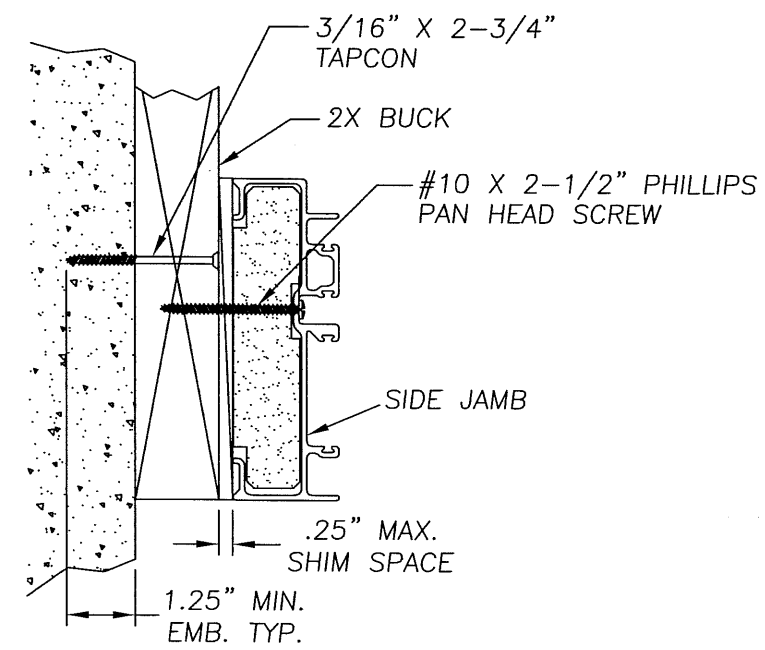

2 VERTICAL CROSS SECTION
2 ACTIVE / FIXED PANEL

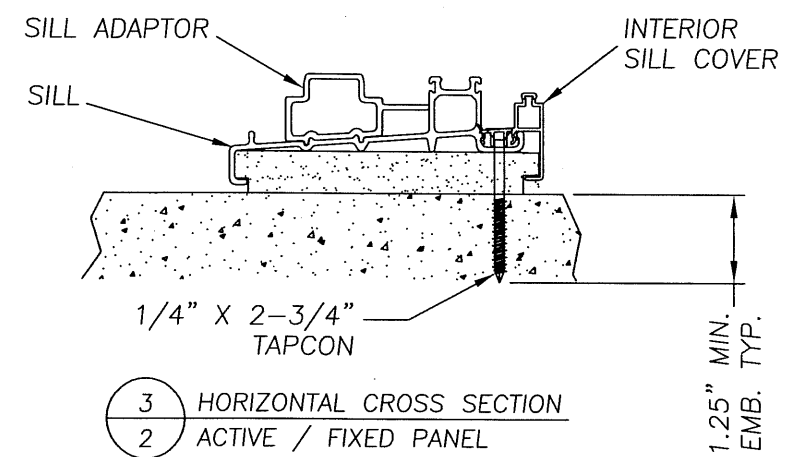

3 HORIZONTAL CROSS SECTION
2 ACTIVE / FIXED PANEL

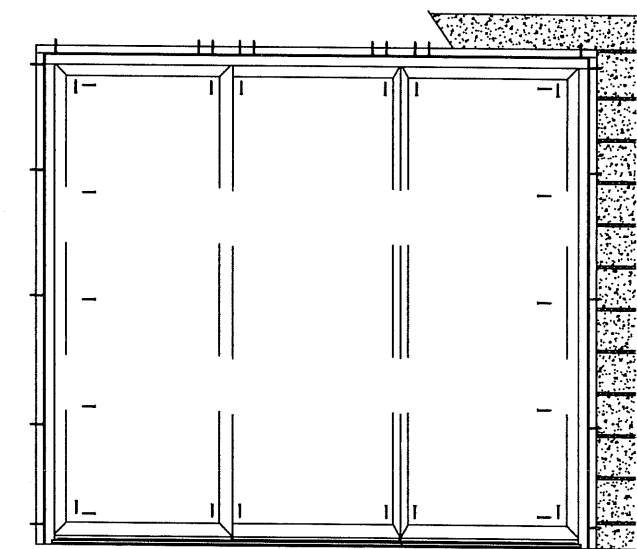
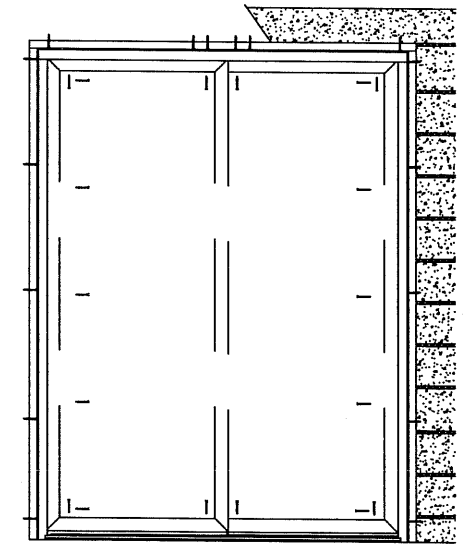
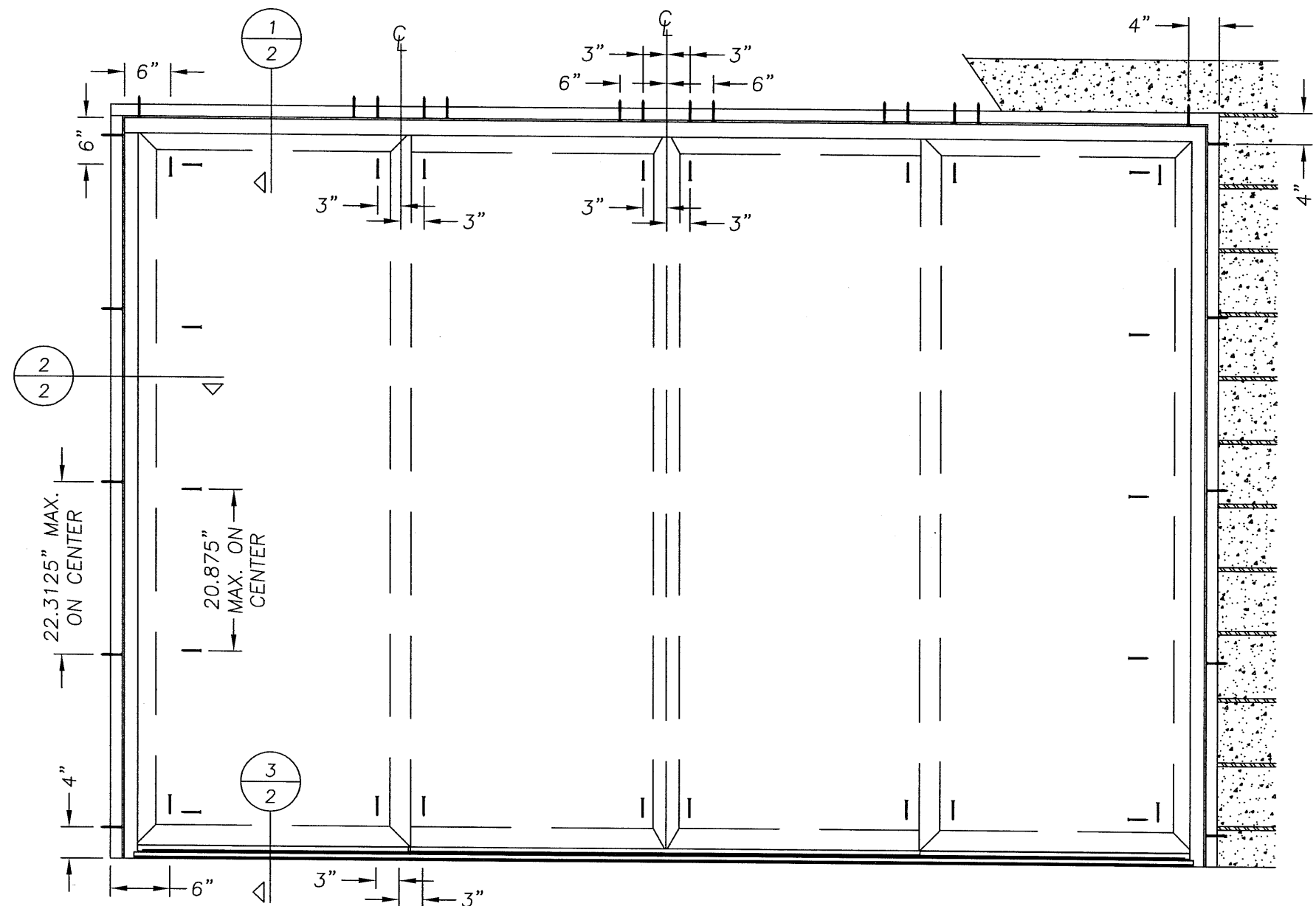

Documents Prepared By:
RW BUILDING CONSULTANTS, INC.
 P.O. Box 230 Valrico FL 33595
 Phone No.: 813.659.9197
 Florida Board of Professional Engineers
 Certificate Of Authorization No. 9813
Wendell W. Hagney
 Wendell W. Hagney, P.E. No. 54158

PRODUCT:
 THERMA-TRU SLIM-LINE
 PATIO DOOR
 SYSTEM ANCHORING
 PART OR ASSEMBLY:
 ANCHOR CROSS SECTION
 MASONRY

NO.	DATE	BY	REVISIONS

DATE: 09/22/05
 SCALE: N.T.S.
 DWG. BY: AEM
 CHK. BY: WWH
 DRAWING NO.: FL-626
 SHEET 2 OF 3

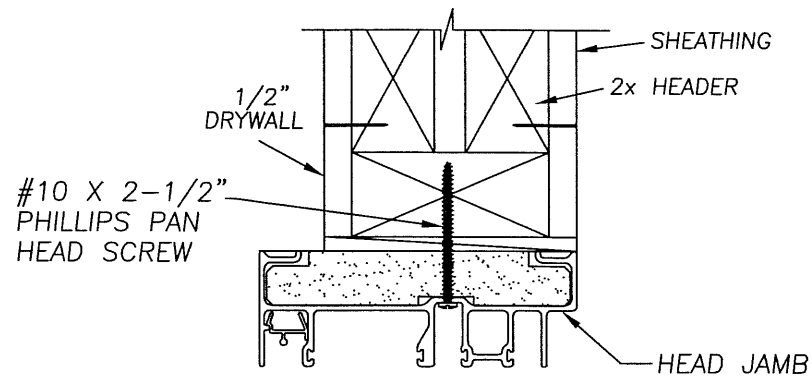

1 HORIZONTAL CROSS SECTION
3 ACTIVE / FIXED PANEL

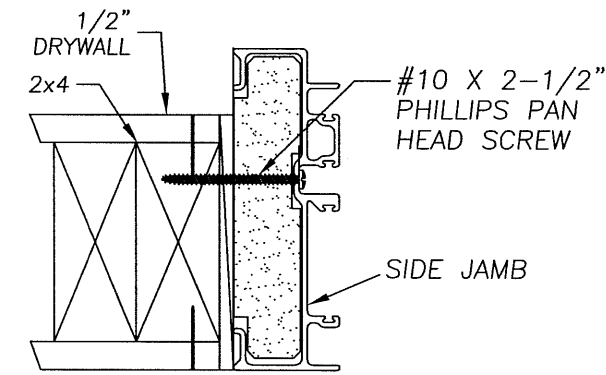

2 VERTICAL CROSS SECTION
3 ACTIVE / FIXED PANEL

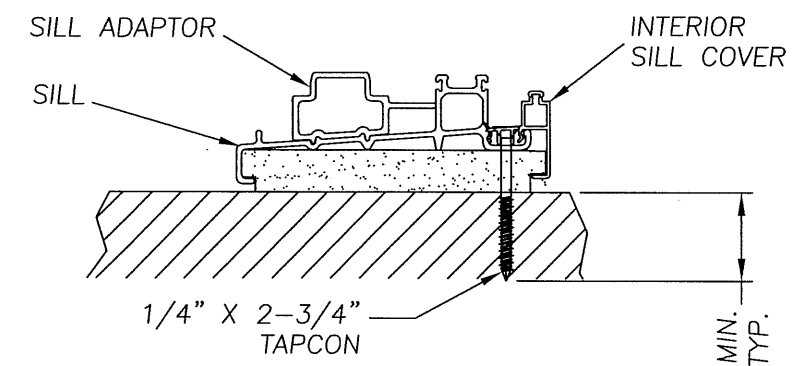
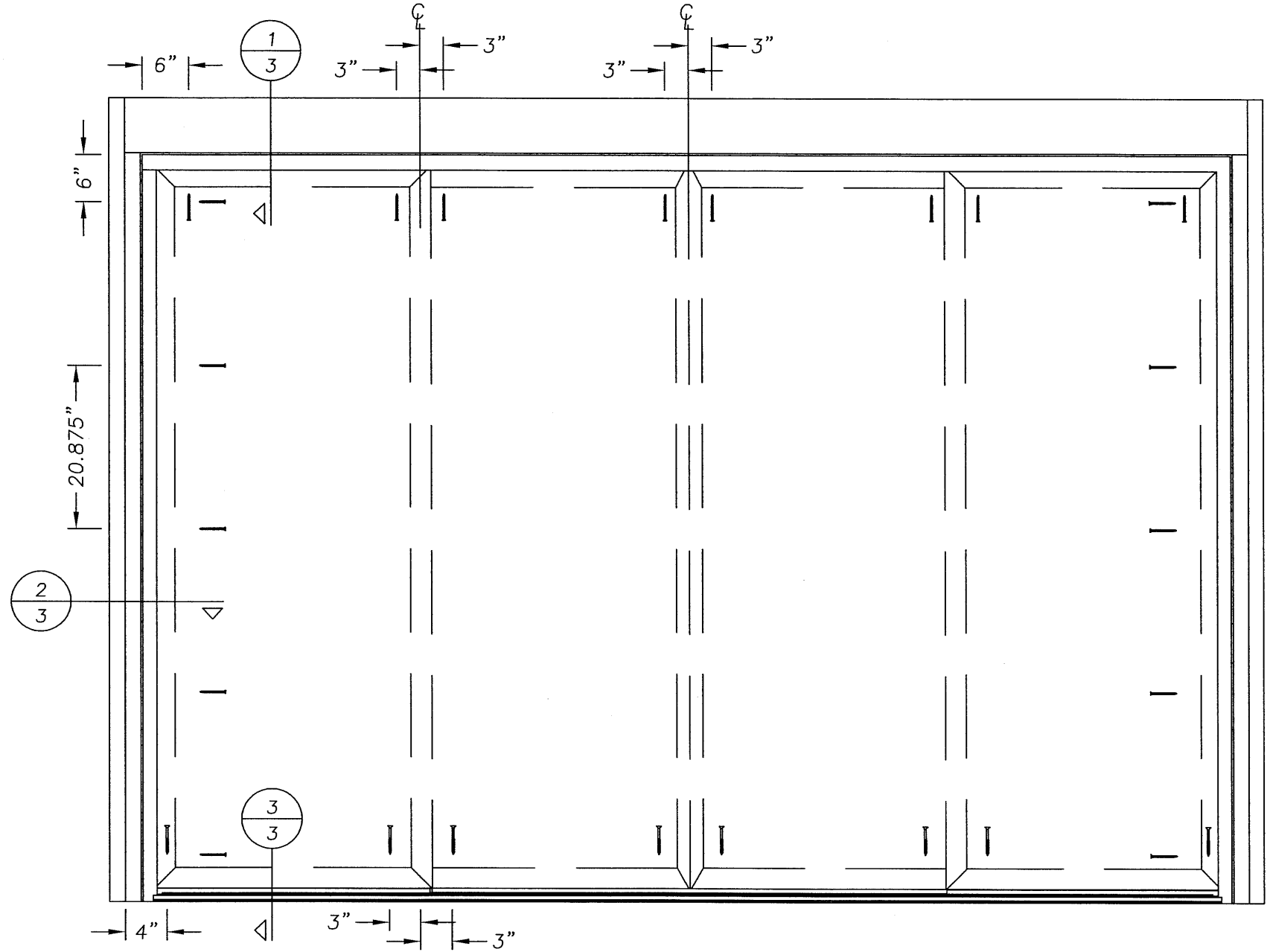

3 HORIZONTAL CROSS SECTION
3 ACTIVE / FIXED PANEL

1.25\"/>

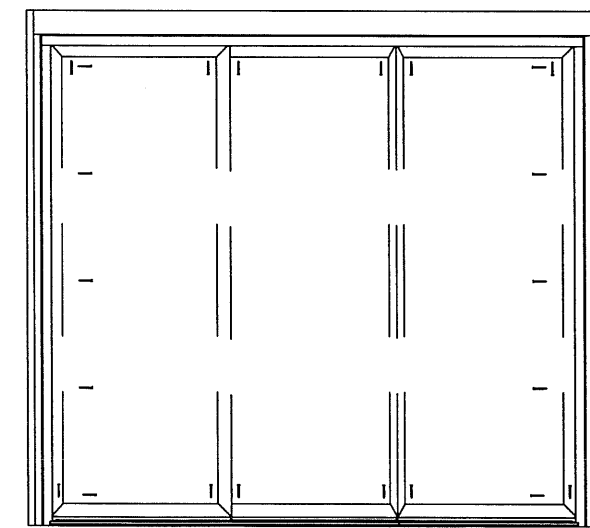
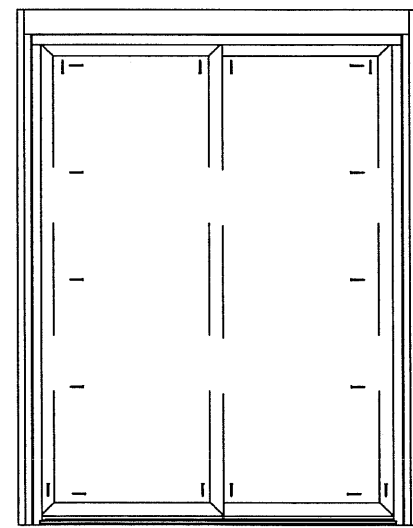

Documents Prepared By:
RW BUILDING CONSULTANTS, INC.
 P.O. Box 230 Vairico FL 33595
 Phone No.: 813.659.9197
 Florida Board of Professional Engineers
 Certificate Of Authorization No. 9813
Wendell W. Heney 9/25/05
 Wendell W. Heney, P.E. No. 54158

PRODUCT:
 THERMA-TRU SLIM-LINE
 PATIO DOOR
 SYSTEM ANCHORING
 PART OR ASSEMBLY:
 ANCHOR CROSS SECTION
 WOOD/STL. STUD

NO.	DATE	BY	REVISIONS

DATE: 09/22/05
 SCALE: N.T.S.
 DWG. BY: AEM
 CHK. BY: WWH
 DRAWING NO.: FL-626
 SHEET 3 OF 3